



## GM ONSTAR LAN DATA BUS INTERFACE

# GMOS-LAN-03

## Installation Instructions

### *Not compatible with amplified sound systems*

**\* READ IMPORTANT WARNING ON PAGE 1 BEFORE ATTEMPTING ANY INSTALLATION**

The GMOS-LAN-03 is designed to retain Onstar and retain the warning chimes that are normally lost when the OEM radio is removed. It also provides a 12 volt accessory output for proper aftermarket radio operation. THE GMOS-LAN-03 also PROVIDES a MUTE, PARKING BRAKE, VSS OR SPEED SENSE, AND A REVERSE OUTPUT TO MAKE INSTALLING AN AFTERMARKET NAVIGATIONAL RADIO SIMPLER AND LESS TIME CONSUMING.

### APPLICATIONS

#### Chevrolet

- Cobalt 2007-08
- HHR 2006-08

#### Pontiac

- G5 2007-08
- Solstice 2006-08

#### Saturn

- Aura 2006-08
- Sky 2006-08

### INTERFACE COMPONENTS

- GMOS-LAN-03 Interface
- 14 pin harness with stripped leads
- 12 pin to 30 pin GM harness



1-800-221-0932



[www.axxessinterface.com](http://www.axxessinterface.com)

© COPYRIGHT 2004-2008 METRA ELECTRONICS CORPORATION Rev. 09-05-08



**\* READ IMPORTANT WARNING  
BEFORE ATTEMPTING ANY INSTALLATION  
\* IMPORTANT WARNING**

THIS PRODUCT INCLUDES INSTRUCTIONS FOR INSTALLATION WHICH MUST BE CAREFULLY FOLLOWED. THE INSTRUCTIONS ARE WORDED IN SUCH A MANNER TO ASSUME THAT THE INSTALLER IS CAPABLE OF COMPLETING THESE TYPE OF ELECTRONIC INSTALLATIONS. IF YOU ARE UNCLEAR AS TO WHAT YOU ARE INSTRUCTED TO DO OR BELIEVE THAT YOU DO NOT UNDERSTAND THE INSTRUCTIONS SO AS TO PROPERLY AND SAFELY COMPLETE THE INSTALLATION YOU SHOULD CONSULT A TECHNICIAN WHO DOES HAVE THIS KNOWLEDGE AND UNDERSTANDING.

**FAILURE TO FOLLOW THESE INSTRUCTIONS CAREFULLY AND TO INSTALL THE INTERFACE AS DESCRIBED COULD CAUSE HARM TO THE VEHICLE OR TO SAFETY SYSTEMS ON THE VEHICLE. INTERFERENCE WITH CERTAIN SAFETY SYSTEMS COULD CAUSE HARM TO PERSONS AS WELL.**

**IF YOU HAVE ANY QUESTIONS IN THIS REGARD PLEASE CALL THE METRA HELP LINE AT: 1-800-221-0932 FOR ASSISTANCE.**



**KNOWLEDGE IS POWER**

Enhance your installation and fabrication skills by enrolling in the most recognized and respected mobile electronics school in our industry. Log onto [www.installerinstitute.com](http://www.installerinstitute.com) or call 800-354-6782 for more information and take steps toward a better tomorrow.



## **TOOLS REQUIRED FOR INSTALLATION**

- Cutting Tool • Tape • Crimping Tool • Connectors (ie: butt-connectors, bell caps, etc.)
- SPDT Relay (optional) • Female Spade Connectors (Optional)

## **WIRING CONNECTIONS**

*\* **Important:** Before beginning any of the following, disconnect the negative battery terminal to prevent accidental short circuit.*

### **FOR INSTALLATION OF AFTERMARKET RADIO ONLY:**

#### **From the 14 pin harness:**

1. Connect the **red** wire to the ignition/accessory wire of the aftermarket radio.
2. Connect the **Blue/white** wire to the amp turn on wire of the aftermarket radio.
3. Connect the **white** wire to the left front positive speaker output of the aftermarket radio.
4. Connect the **white/black** wire to the left front negative speaker output of the aftermarket radio.
5. Connect the **gray** wire to the right front positive speaker output of the aftermarket radio.
6. Connect the **gray/black** wire to the right front negative speaker output of the aftermarket radio.
7. Connect the **brown** wire to the mute wire of the aftermarket radio. If the after market radio does not have a Mute wire, tape up the **brown** wire.

#### **The following wires on the 14 pin harness are for the aftermarket radios that have navigation built in:**

1. Connect the **green** wire to the parking brake wire of the aftermarket navigation radio.
2. Connect the **blue/pink** wire to the VSS or speed sense wire of the aftermarket navigation radio.
3. Connect the **green/purple** wire to the reverse wire of the aftermarket navigation radio.

#### **From the 12 pin harness:**

1. Connect the **Yellow** wire to the 12 volt constant/battery wire of the aftermarket radio.
2. Connect the **Black** wire to the ground wire of the aftermarket radio.
3. The **Black/Yellow** and **Black/White** wires will be discussed later in this manual.

#### **From the 30 pin GM harness:**

1. Connect the **Orange** wire to the illumination wire of the aftermarket radio. If there is no illumination wire just tape the **Orange** wire up.
2. Connect **Orange/White** wire to the dimmer wire of the aftermarket radio. If there is no dimmer wire just tape the **Orange/White** wire up.
3. Connect the **Green** wire to the left rear positive speaker output of the aftermarket radio.
4. Connect the **Green/Black** wire to the left rear negative speaker output of the aftermarket radio.
5. Connect the **Purple** wire to the right rear positive speaker output of the after-market radio.
6. Connect the **Purple/Black** wire to the right rear negative output of the aftermarket radio.

**(See wiring diagram 1 on page 3**



# GMOS-LAN-03

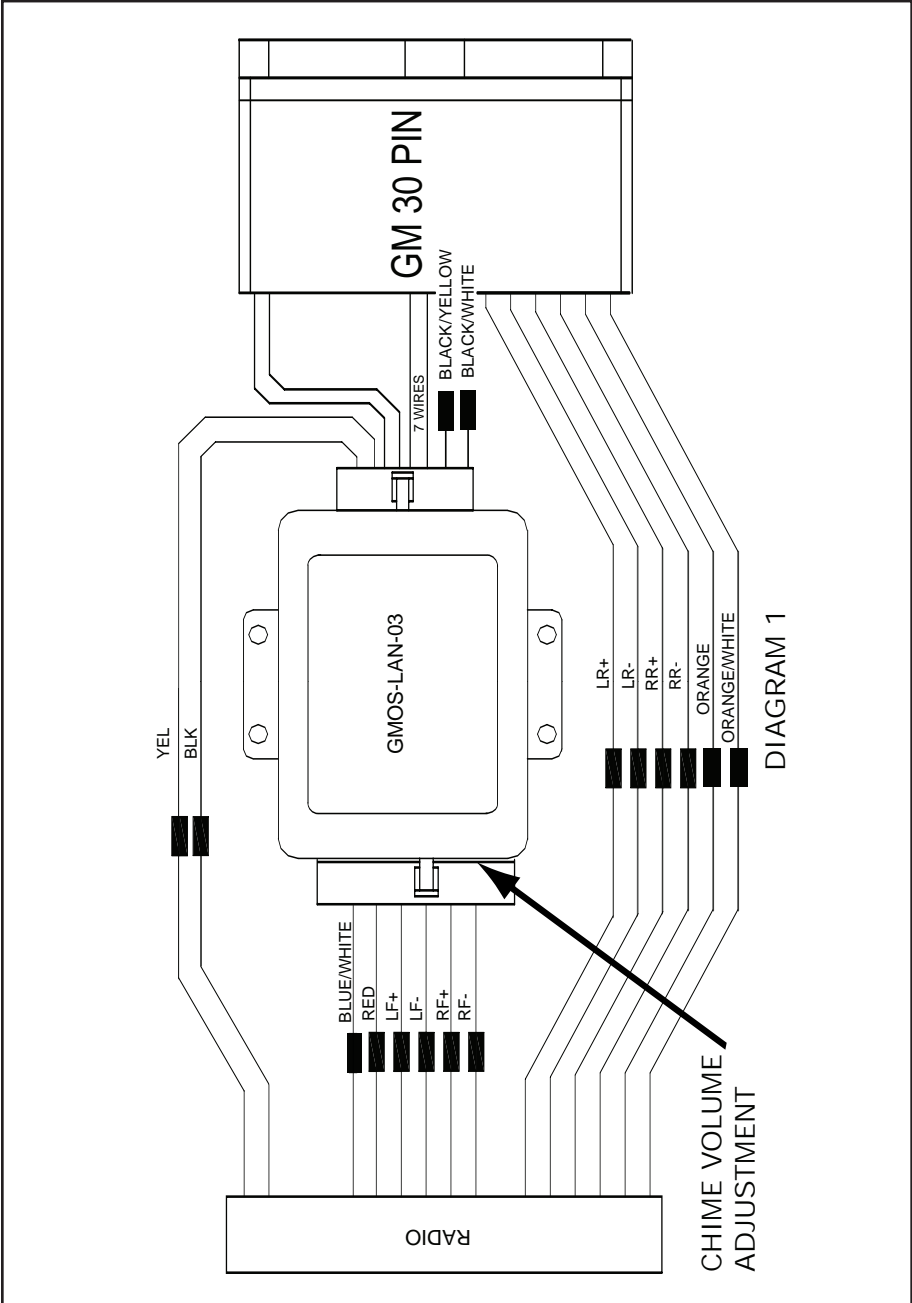



## FOR AFTERMARKET RADIO AND AMPLIFIER

(See wiring diagram on page 6)

### CONNECTIONS TO BE MADE ON THE 14 PIN HARNESS:

1. Connect the **red** wire to the ignition/accessory wire of the aftermarket radio.
2. Connect the **blue/white** wire to the amp turn on wire of the aftermarket radio and to the **blue/white** wire in the 24 pin harness.
3. **White NOT USED**
4. **White/black NOT USED**
5. **Gray NOT USED**
6. **Gray/black NOT USED**
7. Connect the **Brown** wire to the mute wire of the aftermarket radio. If the after market radio does not have a Mute wire, tape up the **Brown** wire.

The following wires on the 14 pin harness are for the aftermarket radios that have navigation built in:

1. Connect the **Green** wire to the parking brake wire of the aftermarket navigation radio.
2. Connect the **Blue/Pink** wire to the VSS or speed sense wire of the aftermarket navigation radio.
3. Connect the **Green/Purple** wire to the reverse wire of the aftermarket navigation radio.

**When completed, plug the 14 pin harness into the GMOS-LAN-03.**

### CONNECTIONS TO BE MADE ON THE 30 PIN GM HARNESS:

1. Connect the **Orange** wire to the illumination wire of the aftermarket radio. If there is no illumination wire just tape the **Orange** wire up.
2. Connect **Orange/White** wire to the dimmer wire of the aftermarket radio. If there is no dimmer wire just tape the **Orange/White** wire up.
3. Connect the **green** wire to the amplifier's left rear positive speaker output.
4. Connect the the **green/black** wire to the amplifier's left rear negative speaker output.
5. Connect the **purple** wire to the amplifier's right rear positive speaker output.
6. Connect the **purple/black** wire to the amplifier's right rear negative speaker output.
7. Cut the **white** wire about half way between the two plugs. Connect the **white** wire from the 24 pin plug to amplifier's left front positive speaker output wire. Connect the **white** wire from the 12 pin plug to the positive speaker wire of the Metra SP-2003 or equivalent.



- 8. Cut the **white/black** wire about half way between the two plugs. Connect the **white/black** wire from the 24 pin plug to amplifier's left front negative speaker output wire. Connect the **white/black** wire from the 12 pin plug to the negative speaker wire of the Metra SP-2003 or equivalent.
- 9. Cut the **gray** wire about half way between the two plugs. Connect the **gray** wire from the 24 pin plug to amplifier's right front positive speaker output wire. Connect the **gray** wire from the 12 pin plug to the positive speakerwire of the Metra SP-2003 or equivalent.
- 10. Cut the **gray/black** wire about half way between the two plugs. Connect the **gray/black** wire from the 24 pin plug to amplifier's right front negative speaker output wire. Connect the **gray/black** wire from the 12 pin plug to the negative speaker wire of the Metra SP-2003 or equivalent.

**Note: If only one SP-2003 is used tape up the gray wires that would normally connect to the second SP-2003 to avoid a short circuit.**

**CONNECTIONS TO BE MADE ON THE 12 PIN HARNESS:**

- 1. Connect the **yellow** wire to the radio's 12 volt battery or memory wire.
- 2. Connect the **black** wire to the radio's ground wire.
- 3. The **black/yellow and black/white** wire is for the **Onstar** volume adjustment. This will be discussed in the **Onstar** and Chime Level Adjustment section of this instruction.

**When completed, plug the 12 pin harness into the GMOS-LAN-03.**

**FINAL WIRING CONNECTIONS**

Make wiring connections using the EIA color code chart shown below and the instructions included with the head unit. Metra recommends making connections as shown below; Strip, Splice, Solder, Tape. Isolate and individually tape ends of any unused wires to prevent electrical short circuit.

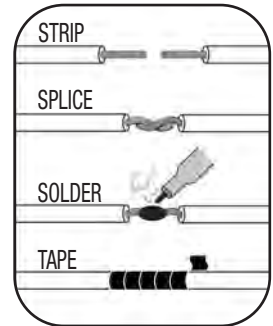

**METRA/EIA WIRING CODE**

12V Ignition / Acc. . . . . Red	Right Front (+) . . . . . Gray
12V Batt / Memory . . . . . Yellow	Right Front (-). . . . . Gray / Black
Ground . . . . . Black*	Left Front (+) . . . . . White
Power Antenna. . . . . Blue	Left Front (-). . . . . White / Black
Amp Turn-On . . . . . Blue / White	Right Rear (+) . . . . . Violet
Amp Ground. . . . . Black / White	Right Rear (-). . . . . Violet / Black
Illumination . . . . . Orange	Left Rear (+) . . . . . Green
Dimmer . . . . . Orange / White	Left Rear (-) . . . . . Green / Black

## AFTERMARKET RADIO AND AMPLIFIER WIRING

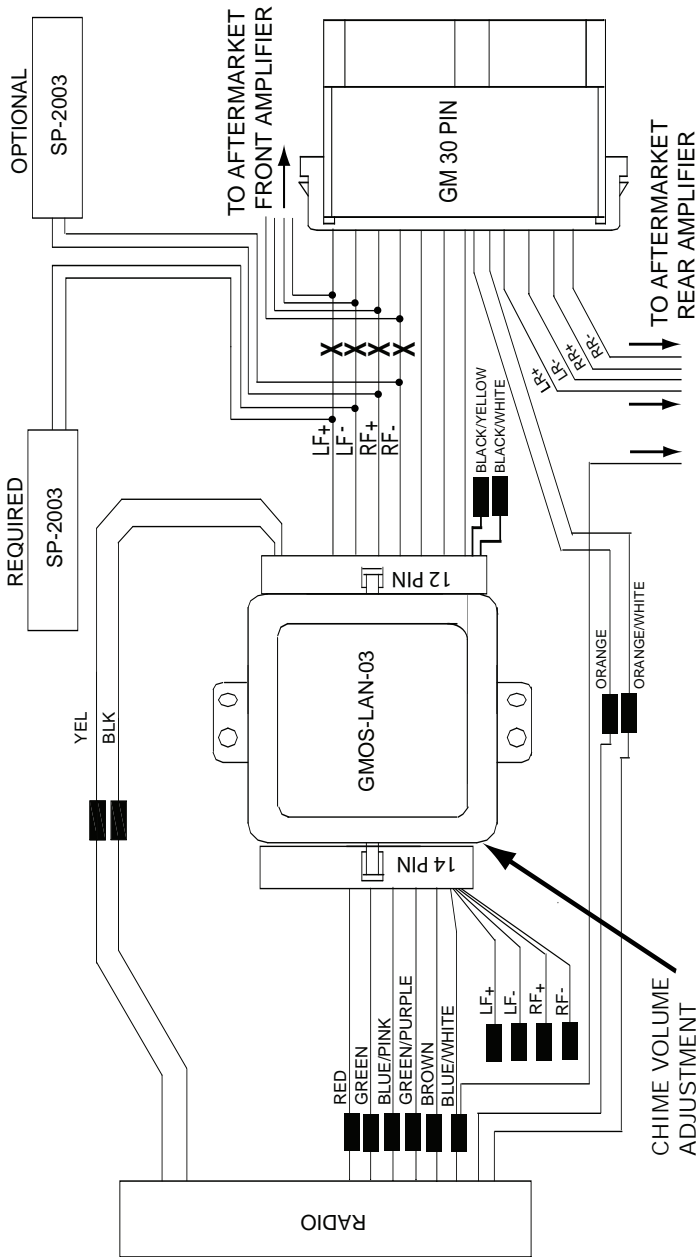



## AUDIBLE TURN SIGNAL

When the factory radio is removed the audible turn signal indicator is lost.

If that turn signal “clicking” is desired follow these steps:

1. Using a SPDT relay (Metra part # E-123), connect pin #85 to the Black/White wire in the 12 pin harness.
2. Connect pin #86 to the 12 volt constant wire on the 12 pin harness.
3. Be sure to cover the other leads of the relay by either using female spade connectors or using tape to cover the leads.

*Now when the turn signal is on, the relay will make the audible “clicking” noise.*

## INSTALLING THE GMOS-LAN-03

1. With all connections completed, plug the 14 and 12 pin harnesses into the GMOS-LAN-03.
2. Reconnect the negative battery terminal.
3. Plug the 30 pin GM harness into the vehicle side harness, and plug the aftermarket radio harness into the aftermarket radio.
4. Cycle the key by turning the ignition on then back off, then back on again to test the radio.

## TESTING THE GMOS-LAN-03

1. Turn the ignition on, and then turn the aftermarket radio on.
2. Push the **Onstar** button, the radio should turn off and you should hear Onstar. Push the Onstar cancel button and the radio should come back on.

## CHIME VOLUME ADJUSTMENT

To adjust the chime volume, use a small screwdriver to rotate the potentiometer, located on the 14 pin harness side of the interface, clockwise to make the chime louder and counterclockwise to make the chime softer.

## ONSTAR LEVEL ADJUSTMENT

To adjust the Onstar volume level find the **Black/Yellow** wire on the 12 pin harness. Push the blue Onstar button, while the voice is speaking tap the **Black/Yellow** wire to ground. There are 4 volume settings for Onstar; once the 4th setting is reached and the **Black/Yellow** wire is tapped to ground it will automatically go back to the first volume setting. Once the volume is set it will stay at that volume until the **Black/Yellow** wire is tapped to ground again. This can be set during installation and then left alone. If user adjustment is desired, a momentary contact switch (sold separately) can be added. Connect one terminal from the switch to ground and the other terminal to the **Black/Yellow** wire. The volume will change one level every time the switch is pressed.



1-800-221-0932



[www.axxessinterface.com](http://www.axxessinterface.com)