

2013 Cadillac Escalade EXT/ESV 6.2L

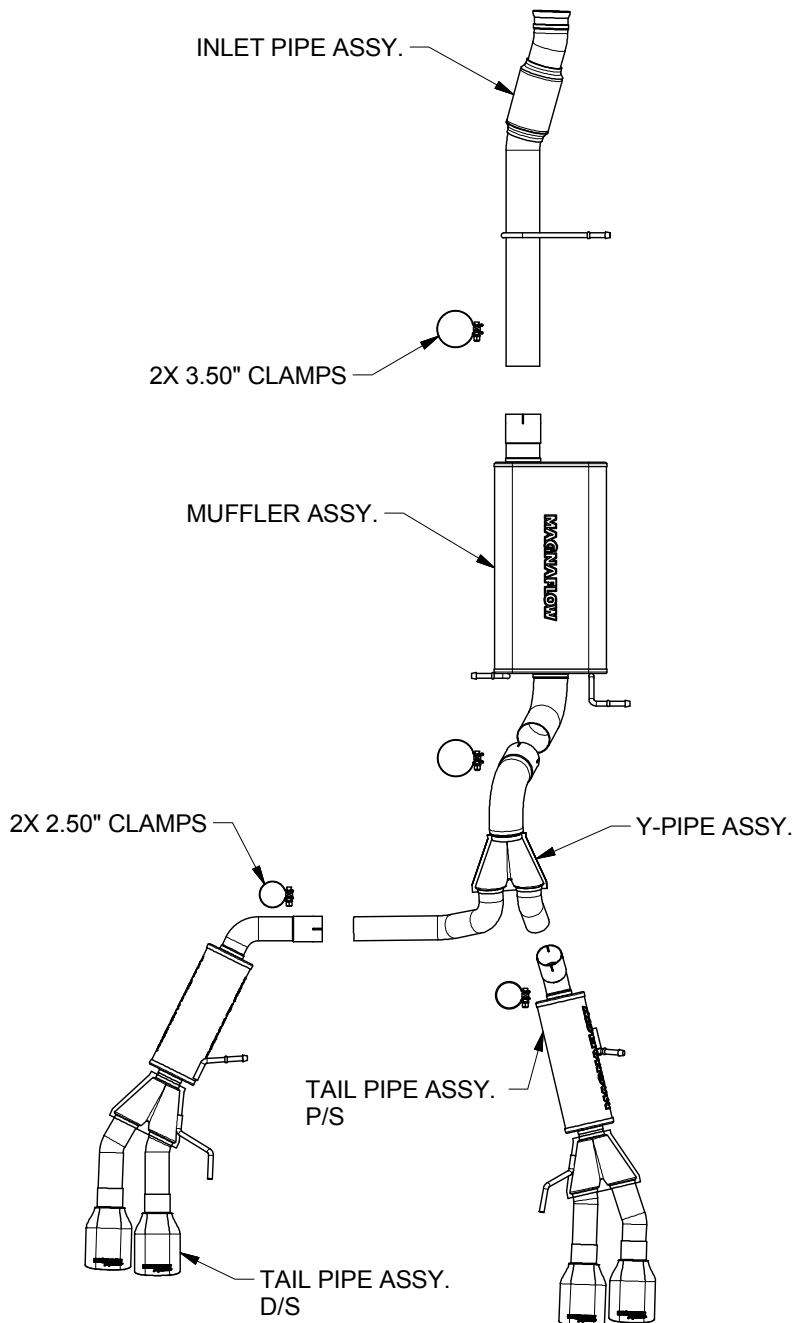

Warning: When working on, under, or around any vehicle exercise caution. Please allow the vehicle's exhaust system to cool before removal, as exhaust system temperatures may cause severe burns. If working without a lift, always consult vehicle manual for correct lifting specifications. Always wear safety glasses and ensure a safe work area. Serious injury or death could occur if safety measures are not followed.

Step 1: To remove your OEM exhaust system you will need to loosen or remove the OEM clamp at the outlet of the catalytic converter. Working front to rear detach all hangers from the rubber insulators. Retain the insulators and fasteners as they will be used to install your new exhaust system. Remove the system from the vehicle.

Step 2: Install your new MAGNAFLOW system by first attaching the Inlet Pipe Assembly to the catalytic converter outlet using the OEM clamp fitting the hanger into the rubber insulator. Install the Muffler Assembly by slipping it onto the the Inlet Assembly and loosley secure with the supplied Clamp. Install the Y-Pipe and Tailpipe Assemblies in a similar fashion.

Step 3: With all components mounted loosely, adjust the system for overall aesthetics and clearance of frame & bodywork. (MAGNAFLOW recommends at least 1/2" of clearance between the exhaust system and any body panels to prevent heat-related body damage or fire.)

Step 4: Once a final position has been chosen for the new system, evenly tighten all fasteners from front to rear. The supplied band clamps must be VERY tight to properly align the pipes and prevent leaks (Approximately 40ft-lbs). Inspect all fasteners after 25-50 miles of operation and retighten if necessary.

**** Magnaflow Performance Exhaust recommends professional installation on all their products**