

### 2000- HONDA S-2000 2.0/2.2L I-4

**Warning:** When working on, under, or around any vehicle exercise caution. Please allow the vehicle's exhaust system to cool before removal, as exhaust system temperatures may cause severe burns. If working without a lift, always consult vehicle manual for correct lifting specifications. Always wear safety glasses and ensure a safe work area. Serious injury or death could occur if safety measures are not followed.

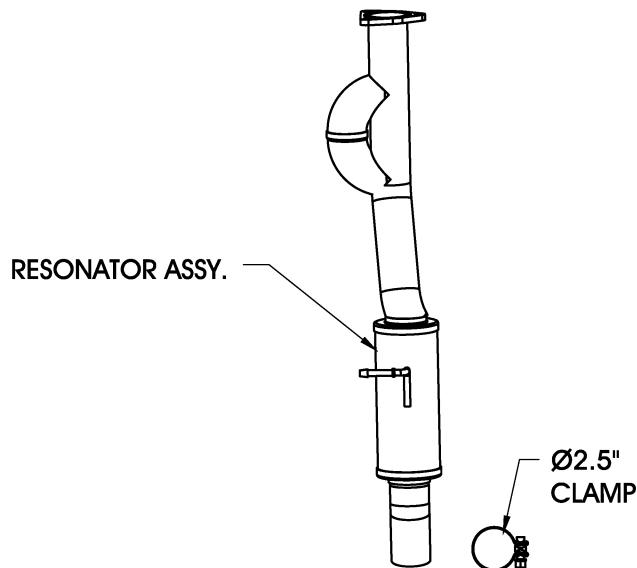

**Step 1:** (Carefully read all instructions before installation) Disconnect the vehicle's battery before removal of the OEM exhaust. This will allow the computer to reset itself with the new system, and prevent electrical accidents. Begin removal of the OEM system by unbolting the 3-bolt flange behind the catalytic converter. Disengage welded hangers from the rubber insulators and extract the system from the vehicle. Do not discard the OEM fasteners or damage the rubber insulators, as they will be reused to mount the new system.

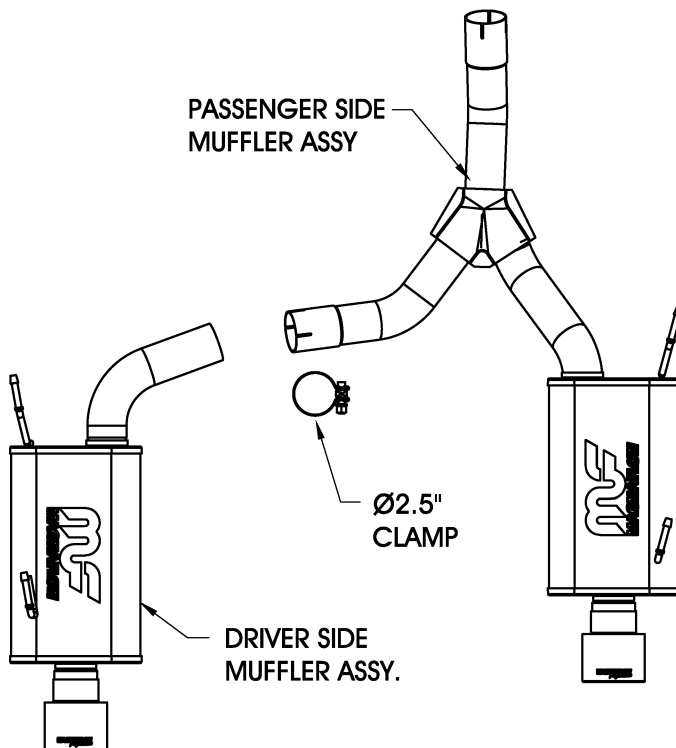

**Step 2:** Working in a front to rear fashion, install the resonator assembly reusing the OEM fasteners. Leave all the clamps and fasteners loose for final adjustment of the complete system. Install the passenger's muffler assembly by using a supplied 2.50" clamp, and by fitting the welded hangers in to the rubber insulators. Install the driver's muffler assembly in a similar fashion.

**Step 3:** With all components mounted loosely, adjust the system for overall aesthetics and clearance of frame & bodywork. (MAGNAFLOW recommends at least 1/2" of clearance between the exhaust system and any body panels to prevent heat-related body damage or fire.)

**Step 4:** Once a final position has been chosen for the new system, evenly tighten all fasteners from front to rear. The supplied band clamps must be VERY tight to properly align the pipes and prevent leaks (Approximately 40ft.-lbs.). Connect the battery and start the vehicle. Inspect all fasteners after 25-50 miles of operation and retighten if necessary.

\*MAGNAFLOW Performance Exhaust recommends professional installation on all their products

Technical support: 1-800-959-9226 ext. 4500

MAGNAFLOW Performance Exhaust - 22961 Arroyo Vista - Rancho Santa Margarita, CA 92688