

1983 -1988 Chevrolet Monte Carlo SS 5.0L

Warning: When working on, under, or around any vehicle exercise caution. Please allow the vehicle's exhaust system to cool before removal, as exhaust system temperatures may cause severe burns. If working without a lift, always consult vehicle manual for correct lifting specifications. Always wear safety glasses and ensure a safe work area. Serious injury or death could occur if safety measures are not followed.

Step 1: (Carefully read all instructions before installation) To detach the OEM Y-Pipe start by unbolting the flanges at the converters and remove the Y-Pipe, retain the fasteners as they will be used to install the new Y-Pipe.

Step 2: Begin installation of the new Y-Pipe by attaching the Y-Pipe assembly flanges to the vehicle using the OEM fasteners.

Step 3: With all components mounted loosely, adjust the system for clearance of frame & bodywork. (MAGNAFLOW recommends at least 1/2" of clearance between the exhaust system and any body panels to prevent heat-related body damage or fire.)

Step 4: Once a final position has been chosen for the new system, evenly tighten all fasteners from front to rear. Inspect all fasteners after 25-50 miles of operation and retighten if necessary.

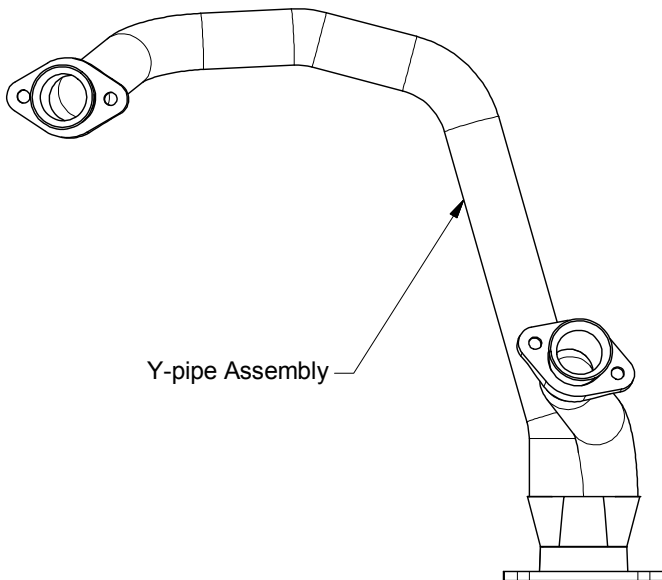

**** Magnaflow Performance Exhaust recommends professional installation on all their products**