

2002— AUDI A4 1.8T FWD

**Warning:** When working on, under, or around any vehicle exercise caution. Please allow the vehicle's exhaust system to cool before removal, as exhaust system temperatures may cause severe burns. If working without a lift, always consult vehicle manual for correct lifting specifications. Always wear safety glasses and ensure a safe work area. Serious injury or death could occur if safety measures are not followed.

**Step 1:** (Carefully read all instructions before installation)

Disconnect the vehicle's battery before removal of the OEM exhaust system. This will allow the computer to reset itself with the new system, and prevent electrical accidents. Begin removal of the OEM exhaust by loosening the OEM clamp located behind the catalytic converter. Do not discard the OEM clamp or damage the rubber insulators, as they will be used to mount the new system. Disengage the welded hangers from the rubber insulators and extract the exhaust system from the vehicle.

**Step 2:** Working in a front to rear fashion, install the Inlet pipe by reusing the OEM clamp. Leave all clamps loose for final adjustments of the complete system.

Using the supplied 2.50" clamp, install the muffler assembly and insert the welded hangers into the OEM rubber insulators. Using a supplied 2.25" clamp, install the driver's side muffler assembly and insert the welded hanger into the OEM insulator. Install the passenger's side muffler assembly in the same fashion.

**Step 3:** With all components mounted loosely, adjust the system for overall aesthetics and clearance of frame & bodywork. (MAGNAFLOW recommends at least 1/2" of clearance between the exhaust system and any body panels to prevent heat-related body damage or fire.)

**Step 4:** Once a final position has been chosen for the new system, evenly tighten all fasteners from front to rear. The supplied band clamps must be VERY tight to properly align the pipes and prevent leaks (Approximately 40ft-lbs). Inspect all fasteners after 25-50 miles of operation and retighten if necessary.

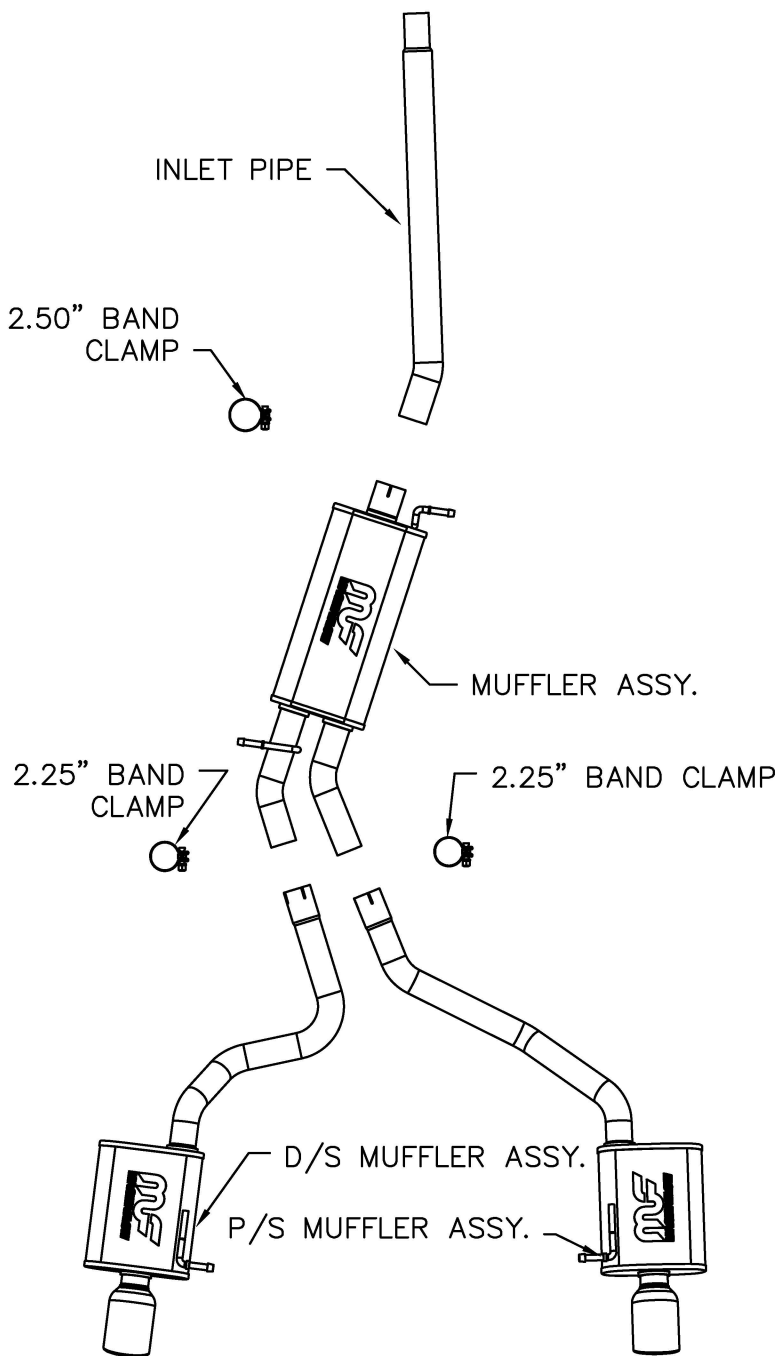

**\*MAGNAFLOW Performance Exhaust recommends professional installation on all their products**

Technical support: 1-800-959-9226 ext. 4500

MAGNAFLOW Performance Exhaust — 22961 Arroyo Vista — Rancho Santa Margarita, CA 92688

16600 1/24/14 R001