

1995 - 1999 BMW M3 E36 I6

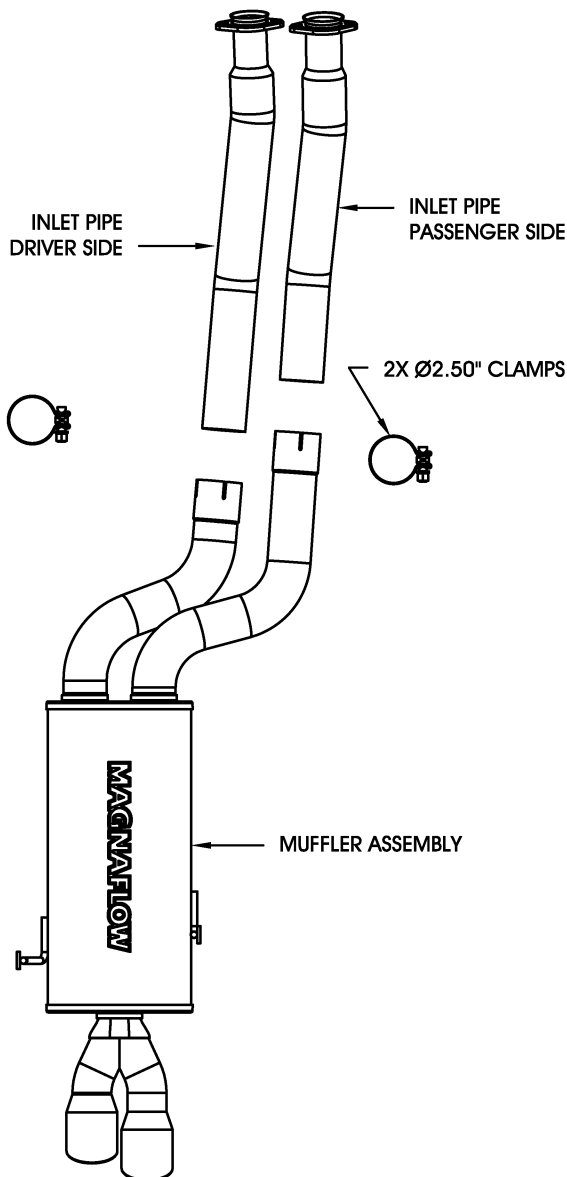

Warning: When working on, under, or around any vehicle exercise caution. Please allow the vehicle's exhaust system to cool before removal, as exhaust system temperatures may cause severe burns. If working without a lift, always consult vehicle manual for correct lifting specifications. Always wear safety glasses and ensure a safe work area. Serious injury or death could occur if safety measures are not followed.

Step 1: (Carefully read all instructions before installation) Disconnect the vehicle's battery before removal of the OEM exhaust. This will allow the computer to reset itself with the new system, and prevent electrical accidents. Begin by loosening the flanges that connect the muffler to the catalytic converters. Do not discard the OEM fasteners or damage the OEM rubber insulators as they will be reused to mount the new system. Remove the fasteners that clamp the muffler to the hanger brackets and remove the muffler assembly. Remove the OEM hanger brackets as well.

Step 2: Begin installing the new system by connecting the two inlet pipes to the OEM catalytic converters at the flanges using the OEM hardware. Leave all clamps and fasteners loose for final adjustment of the complete system. Next fit the muffler inlets over the pipe outlets and use the supplied 2.50" clamps to secure them. Finally install the welded hanger brackets to the vehicle.

Step 3: With all components mounted loosely, adjust the system for overall aesthetics and clearance of frame & bodywork. (MAGNAFLOW recommends at least 1/2" of clearance between the exhaust system and any body panels to prevent heat-related body damage or fire.)

Step 4: Once a final position has been chosen for the new system, evenly tighten all fasteners from front to rear. The supplied band clamps must be VERY tight to properly align the pipes and prevent leaks (approximately 40ft. lbs.). Inspect all fasteners after 25-50 miles of operation and retighten if necessary.