

### Sys C/B 2008 Subaru Impreza WRX 2.5L Turbo Wagon

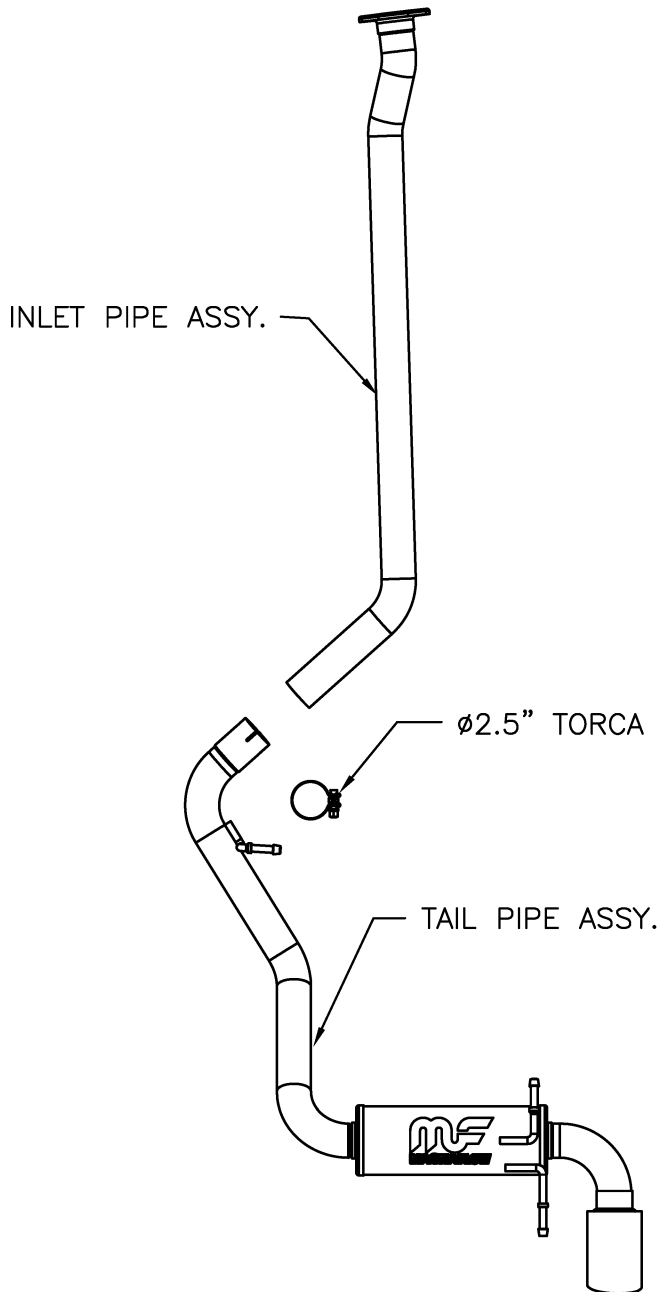

**Warning:** When working on, under, or around any vehicle exercise caution. Please allow the vehicle's exhaust system to cool before removal, as exhaust system temperatures may cause severe burns. If working without a lift, always consult vehicle manual for correct lifting specifications. Always wear safety glasses and ensure a safe work area. Serious injury or death could occur if safety measures are not followed.

**Step 1:** (Carefully read all instructions before installation) Disconnect the vehicle's battery before removal of the OEM exhaust. This will allow the computer to reset itself with the new system, and prevent electrical accidents.

**Step 2:** Remove the OEM exhaust system by first unbolting the flange located behind the catalytic converter. Carefully remove the exhaust system making sure you retain any hardware and insulating rubber as it will be used on your new Cat-Back system.

**Step 3:** Before installation it is recommended that you lay out all the components of your new system to ensure orientation. You are now ready to install your new system. Work from the front to the rear of the vehicle. Begin by bolting the Inlet pipe assembly to the catalytic converter. Attach the tail pipe assembly into the OEM rubber insulators. Secure to the inlet pipe assembly using the supplied 2.5" TORCA Clamp.

**Step 4:** With all components mounted loosely, adjust the system for overall aesthetics and clearance of frame & bodywork. (MAGNAFLOW recommends at least 1/2" of clearance between the exhaust system and any body panels to prevent heat-related body damage or fire.)

**Step 5:** Once a final position has been chosen for the new system, evenly tighten all fasteners from front to rear. The supplied band clamps must be VERY tight to properly align the pipes and prevent leaks (Approximately 40ft-lbs). U-bolt clamps should be tightened to approximately 30-35ft-lbs. Inspect all fasteners after 25-50 miles of operation and retighten if necessary.

Technical support: 1-800-959-9226 ext. 4500

\*MAGNAFLOW Performance Exhaust recommends professional installation on all their products