

2003-07 FORD F-SERIES - V8 6.0L, CREW CAB LONG/SHORT BED

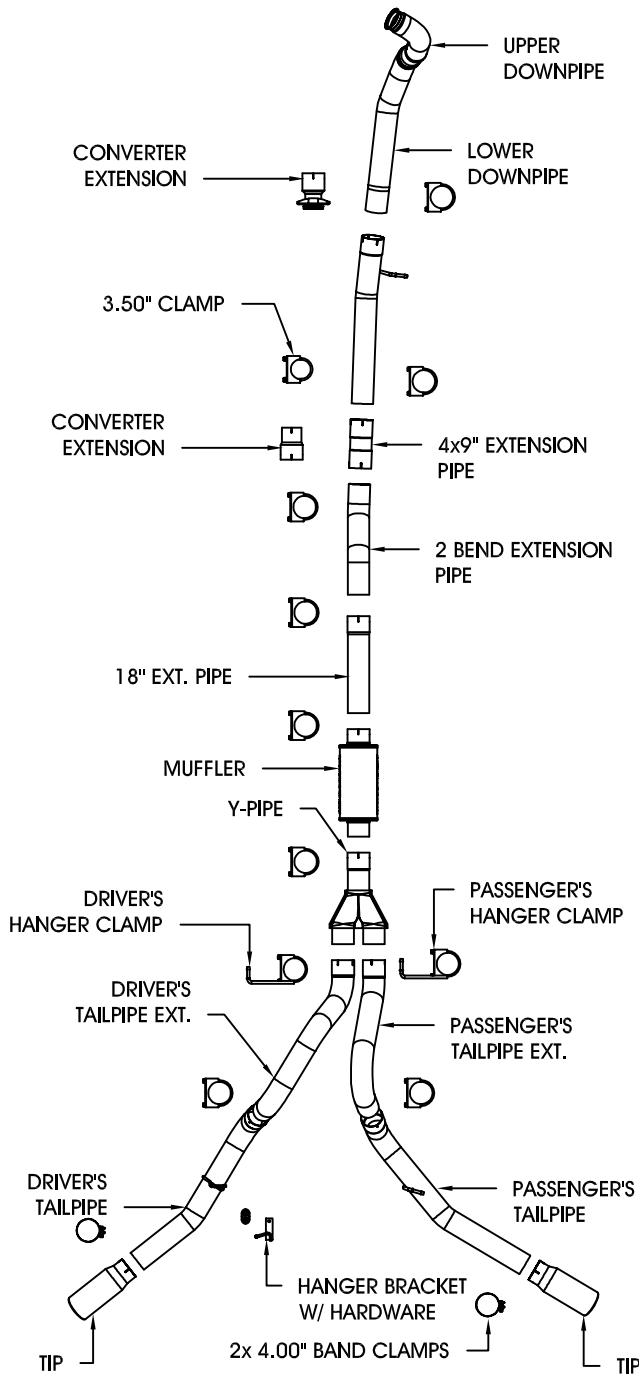

Note: MAGNAFLOW advises against the removal of catalytic converters. If the vehicle was originally equipped with a catalytic converter, this exhaust system is intended for off-road and racing applications only.

Warning: When working on, under, or around any vehicle exercise caution. Please allow the vehicle's exhaust system to cool before removal, as exhaust system temperatures may cause severe burns. If working without a lift, always consult vehicle manual for correct lifting specifications. Always wear safety glasses and ensure a safe work area. Serious injury or death could occur if safety measures are not followed.

Step 1: (Carefully read all instructions before installation)

Disconnect the vehicle's battery before removal of the OEM exhaust. This will allow the computer to reset itself with the new system, and prevent electrical accidents. You will need to temporarily remove the passenger's side upper stabilizer bar mount bolt, and loosen the lower mounting bolt as shown in Diagram 2. This will allow the bar to swing out of the way. The next step is to remove the lower mounting bolt of the passenger's side rear shock as shown in Diagram 3 to allow the shock to swing out of the way. Unbolt the rear half of the OEM exhaust system and disengage the welded hangers from the rubber insulators to remove the muffler/tailpipe assembly from the vehicle. Loosen the V-band clamp that attaches the downpipe to the turbocharger as shown in Diagram 4. Do not overstress the clamp, or attempt to remove it. Once the clamp is loose, slip the V-band clamp off of the downpipe, and allow it to rest on the turbo housing. The remainder of the OEM exhaust can now be removed from underneath the vehicle.

Step 2: Begin installation of the new system by fitting the new downpipe into position from under the vehicle. Due to the tight clearances, it may be difficult to fit the downpipe into place, but it will fit. Carefully attach the new downpipe to the turbo reusing the OEM V-band clamp. Fasten the clamp snugly to rotate the downpipe when adjusting the complete system. You can now reinstall the stabilizer bar. Refer to Ford's shop manual for proper torque specifications of all mounts.

*MAGNAFLOW Performance Exhaust recommends professional installation on all their products

Technical support: 1-800-959-9226 ext. 4500

2003-07 FORD F-SERIES - V8 6.0L, CREW CAB LONG/SHORT BED

DIAGRAM 2



DIAGRAM 3



Note: MAGNAFLOW advises against the removal of catalytic converters. If the vehicle was originally equipped with a catalytic converter, this exhaust system is intended for off-road and racing applications only.

Warning: When working on, under, or around any vehicle exercise caution. Please allow the vehicle's exhaust system to cool before removal, as exhaust system temperatures may cause severe burns. If working without a lift, always consult vehicle manual for correct lifting specifications. Always wear safety glasses and ensure a safe work area. Serious injury or death could occur if safety measures are not followed.

Step 2: Working rearward, install the downpipe extension using the pre-welded 4.00" clamp. Use the converter extension pipes if you would like to retain the catalytic converter. If you are removing the catalytic converter, install the downpipe extension and 4x9" pipe using the supplied 4" clamps and by fitting the welded hanger into the OEM rubber insulator. Leave all clamps and fasteners snug for final adjustment of the complete system. Crew Cab-Long Bed models use the 18" extension pipe, shorter truck models may need to trim the 18" extension pipe for a proper fit or discard it. Once you have determined which extension pipes are needed, install them using the supplied 4.00" clamps as shown. Install the muffler, Y-pipe, tailpipe extensions, and tailpipes in a similar fashion using the supplied clamps, hanger clamps, and hanger bracket. The hanger bracket is to be installed on a predrilled hole in the frame as shown in Diagram 6. *Note:* The passenger's hanger clamp is slightly longer on the end than the driver's hanger clamp. The 4.00" band clamps are supplied to fasten the tips to the tailpipes.

Step 3: With all components mounted loosely, adjust the system for overall aesthetics and clearance of frame & bodywork. (MAGNAFLOW recommends at least 1/2" of clearance between the exhaust system and any body panels to prevent heat-related body damage or fire.)

Step 4: Once a final position has been chosen for the new system, evenly tighten all fasteners from front to rear. The supplied band clamps must be VERY tight to properly align the pipes and prevent leaks (Approximately 65ft-lbs). U-bolt clamps should be tightened to approximately 30-35ft-lbs. Inspect all fasteners after 25-50 miles of operation and retighten if necessary.

*MAGNAFLOW Performance Exhaust recommends professional installation on all their products

Technical support: 1-800-959-9226 ext. 4500

2003-07 FORD F-SERIES - V8 6.0L, CREW CAB LONG/SHORT BED

DIAGRAM 4



DIAGRAM 5



DIAGRAM 6



Note: MAGNAFLOW advises against the removal of catalytic converters. If the vehicle was originally equipped with a catalytic converter, this exhaust system is intended for off-road and racing applications only.

Warning: *When working on, under, or around any vehicle exercise caution. Please allow the vehicle's exhaust system to cool before removal, as exhaust system temperatures may cause severe burns. If working without a lift, always consult vehicle manual for correct lifting specifications. Always wear safety glasses and ensure a safe work area. Serious injury or death could occur if safety measures are not followed.*

**MAGNAFLOW Performance Exhaust recommends professional installation on all their products*

Technical support: 1-800-959-9226 ext. 4500

MAGNAFLOW Performance Exhaust - 22961 Arroyo Vista - Rancho Santa Margarita, CA 92688