

2004.5-2007 DODGE RAM 5.9L CUMMINS DIESEL

Warning: When working on, under, or around any vehicle exercise caution. Please allow the vehicle's exhaust system to cool before removal, as exhaust system temperatures may cause severe burns. If working without a lift, always consult vehicle manual for correct lifting specifications. Always wear safety glasses and ensure a safe work area. Serious injury or death could occur if safety measures are not followed.

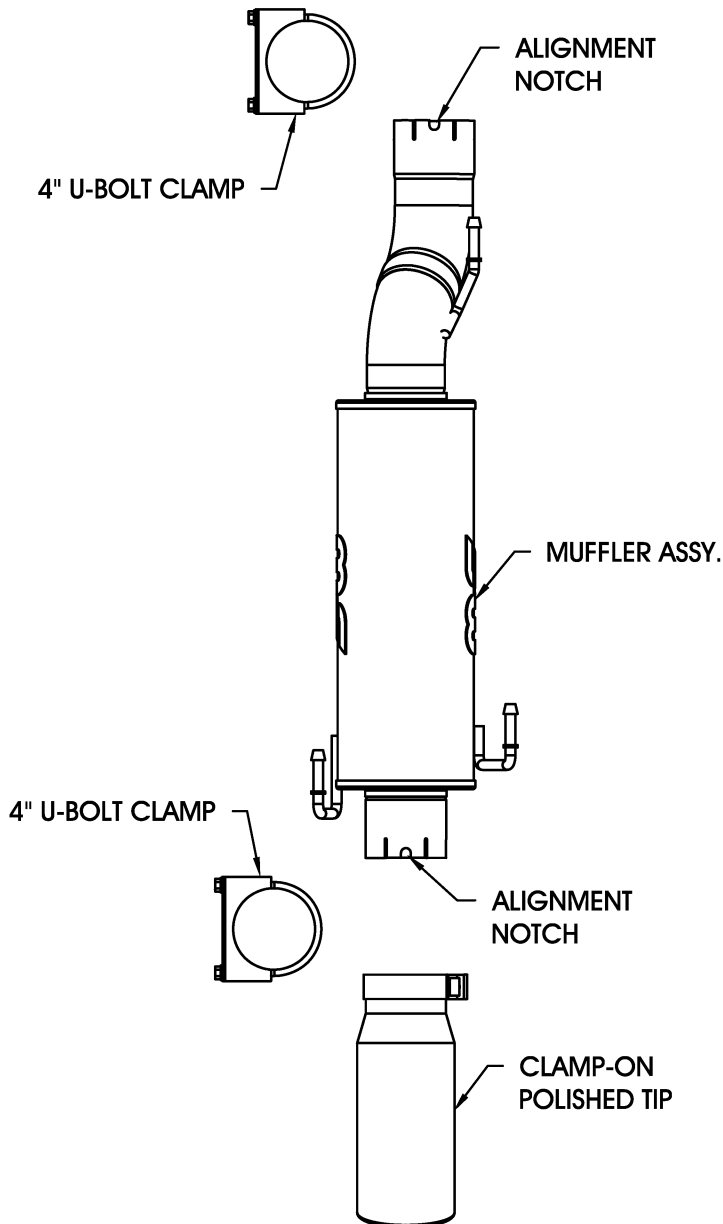

Step 1: (Carefully read all instructions before installation) Disconnect the vehicle's battery before removal of the OEM exhaust system. This will allow the computer to reset itself with the new system, and prevent electrical accidents. Remove the OEM muffler by unbolting the U-bolt clamps and disengaging the muffler from the OEM rubber insulators. Be careful not to damage the OEM rubber insulators, as they will be re-used to mount the new system.

Step 2: Install the new system by inserting the welded hangers into the OEM rubber insulators. Line up the alignment notches to the OEM system, and use the supplied 4" U-bolt clamps to fasten the front and rear extensions of the muffler assembly. Leave all fasteners loose for final adjustment. The polished tip has a pre-welded clamp and can be bolted directly to the tailpipe, however, you may want to trim the tailpipe for final tip placement.

Step 3: With all components mounted loosely, adjust the system for overall aesthetics and clearance of frame & bodywork. (MAGNAFLOW recommends at least 1/2" of clearance between the exhaust system and any body panels to prevent heat-related body damage or fire.)

Step 4: Once a final position has been chosen for the new system, evenly tighten all fasteners from front to rear. The supplied band clamps must be VERY tight to properly align the pipes and prevent leaks (Approximately 40ft-lbs). U-bolt clamps should be tightened to approximately 30-35ft-lbs. Inspect all fasteners after 25-50 miles of operation and retighten if necessary.

*MAGNAFLOW Performance Exhaust recommends professional installation on all their products

Technical support: 1-800-959-9226 ext. 4500

MAGNAFLOW Performance Exhaust - 22961 Arroyo Vista - Rancho Santa Margarita, CA 92688