

2008 - Ford F-Series Super - Duty 6.4L V8

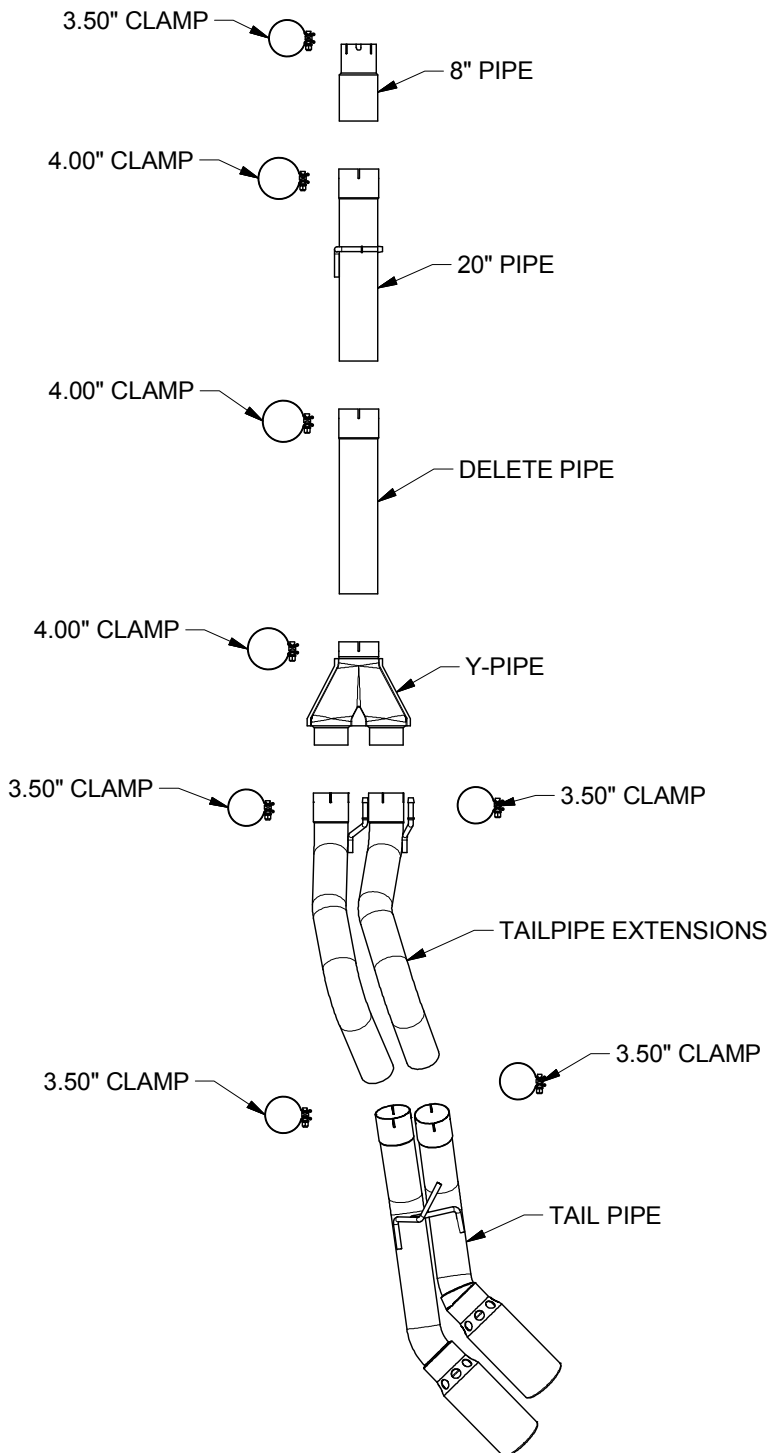

Warning: When working on, under, or around any vehicle exercise caution. Please allow the vehicle's exhaust system to cool before removal, as exhaust system temperatures may cause severe burns. If working without a lift, always consult vehicle manual for correct lifting specifications. Always wear safety glasses and ensure a safe work area. Serious injury or death could occur if safety measures are not followed.

Step 1: (Carefully read all instructions before installation) Loosen the band clamp fastening the muffler assembly to the particulate filter. You can now disengage the welded hangers from the rubber insulators and remove the exhaust system from the vehicle. Do not damage the OEM rubber insulators, as they will be reused to mount the new system. You may also cut the tailpipe behind the muffler to aid in removal of the system.

Step 2: Install the 8" inlet pipe making sure the alignment notch fits around the peg on the filter outlet pipe using the supplied 3.50" clamp. Leave all clamps loose for final adjustment of the complete system. CC/LB models require the 20" extension pipe, shorter models will now use the delete pipe and 4.00" clamps. Install the tailpipe extensions and tailpipe assembly in a similar fashion using the supplied 3.50" clamps and by fitting the welded hangers into the rubber insulators.

Step 3: With all components mounted loosely, adjust the system for overall aesthetics and clearance of frame & bodywork. (MAGNAFLOW recommends at least 1/2" of clearance between the exhaust system and any body panels to prevent heat-related body damage or fire.)

Step 4: Once a final position has been chosen for the new system, evenly tighten all fasteners from front to rear. The supplied band clamps must be VERY tight to properly align the pipes and prevent leaks (Approximately 40ft-lbs). U-bolt clamps should be tightened to approximately 30-35ft-lbs. Inspect all fasteners after 25-50 miles of operation and retighten if necessary.

**** Magnaflow Performance Exhaust recommends professional installation on all their products**