

INSTALLATION INSTRUCTIONS

Atomic LS Master Truck EFI Kits **PN 2957 - 3-Bolt Manifold** **PN 2958 - 4-Bolt Manifold**

ONLINE PRODUCT REGISTRATION: Register your MSD product online. Registering your product will help if there is ever a warranty issue with your product and helps the MSD R&D team create new products that you ask for! Go to www.msperformance.com/registration.

Thank you for selecting the Atomic LS Truck EFI System! MSD's Atomic EFI systems are designed with two major goals; to simplify installation of EFI and deliver better overall performance from your engine. Simplicity is achieved through wired-less technology to ease installation plus the Atomic is simple to program with no PC required! Performance is delivered through advanced control of the fuel and ignition, just as you'd expect from MSD.

Parts Included:

- | | |
|--|---------------------------------------|
| 2 - Fuel Rail Assemblies | 4 - Fuel Rail Brackets |
| 1 - Power Module | 8 - Injector Retainer Clips |
| 1 - Handheld Monitor | 8 - Short Spacers, Black (PN 2957) |
| 1 - Wideband O2 Sensor | 8 - Long Spacers, Black (PN 2958) |
| 1 - Weld - in O2 Sensor Bung, Plug, and Crush Washer | 4 - 6mm x 16mm HEX Head Bolts |
| 1 - CAN Cable | 8 - 6mm x 12mm Bolts |
| 1 - Power Module Main Harness | 4 - 6/32" Socket Head Cap Screws |
| 1 - Power Harness | 8 - 8/32" Socket Head Cap Screws |
| 1 - Cam Sensor Harnesses 4x (PN 2958) | 8 - M6 x 90mm Intake Bolts (PN 2957) |
| 2 - Cam Sensor Harnesses 1x & 4x (PN 2957) | 8 - M6 x 100mm Intake Bolts (PN 2958) |
| 1 - Crank Sensor Harnesses 58x (PN 2958) | 8 - #12 Washers |
| 2 - Crank Sensor Harnesses 24x & 58x (PN 2957) | 2 - Hose Clamps |
| 1 - MAP Sensor Harnesses (PN 2957) | 1 - 15" High Pressure Fuel Hose |
| 2 - MAP Sensor Harnesses (PN 2958) | 2 - Fuel Rail End Caps |
| 1 - TPS Harness | |
| 1 - VVT Harness (PN 2958) | |
| 4 - Delphi Injector Harnesses (PN 2957) | |
| 4 - EV6 Injector Harnesses (PN 2958) | |
| 1 - IAT Sensor and Grommet | |
| 1 - 4GB Micro SD Card | |
| 4 - Grommets, Sleeves, and Mounting Screws | |

Parts Required, Not Included:

Fuel System: Fuel Pump, Fuel Filter, Injectors, Injector O-Rings, Regulator, and Fuel Line.
Thread sealer for intake bolts.

Not legal for use on pollution controlled vehicles: The MSD Atomic EFI system is not CARB approved for use on emission controlled vehicles.

⚠ WARNING Installation of this product requires detailed knowledge of automotive systems and repair procedures. Installation of fuel system parts and any fuel tank modifications must be carried out by a qualified automotive technician. Installation of fuel system parts requires handling of gasoline. Ensure that work is performed in a well ventilated area with an approved fire extinguisher nearby. Extinguish all open flames, prohibit smoking and eliminate all sources of ignition in the area of the vehicle before beginning the installation. When working with fuel systems, eye goggles and other safety apparel should be worn to protect against debris and sprayed gasoline. The finished work must be thoroughly checked to ensure there are no fuel leaks.

CAPABILITIES

The Atomic LS Truck kit is designed to fit the original equipment (OE) 3-bolt and 4-bolt throttle body truck intakes. The Atomic LS Truck is a self integrated Fuel and Ignition controller for GEN-III and GEN-IV motors that requires no programming with a PC. The interface is controlled through a supplied hand held controller. The ECU only needs basic configuration information. Once the engine warms up to operating temperature, the ECU tunes itself using a basic configuration to ensure the best performance and throttle response for your engine. The atomic will adjust timing and fuel curves on the fly which in turn produces the smoothest idle, best fuel economy, and superior wide open throttle performance at all times. This also means that weather and altitude changes aren't a problem with this system. The Atomic LS Truck kit supports the factory Variable Valve Timing (VVT) configuration as well. The Atomic LS Truck kit uses all OE sensors with the exception of the wideband O2 sensor. The Atomic LS Truck system only supports a cable driven throttle body at this time.

Note: The 4-bolt electronic control throttle body will have to be converted to a cable drive throttle body like the MSD PN 2940.

COMPONENTS

Power Module: The Power Module of the Atomic LS is the communication hub of the system and provides the high current fuel pump circuit and other input/outputs for optional features. The unit has two ports for the MSD CAN system as well as a wiring harness. There are connections for the WB02, the Handheld Monitor as well as Rail Power and CAN communication to the integrated fuel rails.



Power Module

Handheld Programmer: The Atomic LS Truck kit is a self-tuning fuel and ignition control system. The system only needs the basic engine configuration information to build a fuel table for the engine. The Handheld Programmer is used to enter all the engine parameters into the ECU, and uses the MSD CAN to communicate with the ECU. Once the engine has been started and warmed up to operating temperature, the ECU will monitor the sensors. The ECU will then adjust the fuel tables and ignition in order to maintain a properly running engine.



Handheld Programmer

Fuel Rails/ECU: The Fuel Rails/ECU is combination of the electronics that drive an ECU and a fuel rail assembly built into one unit. All of the engine sensor connectors (except for the wideband O2 which connects to the Power Module directly) are found on the fuel rails. The fuel rails are equipped with -6AN fittings, but will accept -8AN fittings (the internal rail orifice is the same diameter as the -8AN).

Drivers Side Fuel Rail

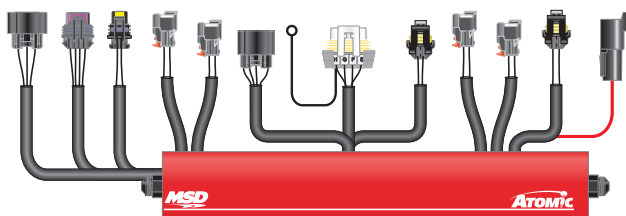

Passenger Side Fuel Rail

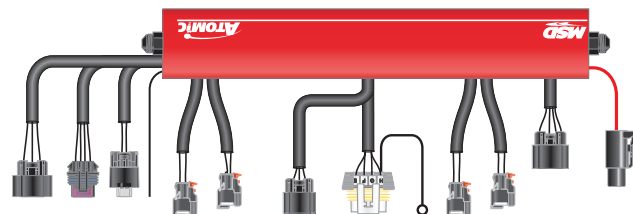

PREPARING THE INTAKE MANIFOLD FOR INSTALLATION OF THE ATOMIC LS FUEL RAILS

The intake manifold must be modified in order to install the Atomic LS fuel rails. Removal of the intake manifold for modification and installation of the fuel rails is recommended but not required. If care is taken while the intake is removed from the motor, the intake gaskets can be reused.

- Cut the mounting bosses that hold the factory fuel rails off. (Figure 1a and Figure 1b).
- Using a drift pin or a center punch, knock the factory bolts out of the centering bushing used to align the intake on eight of the ten intake bolts/bushings (Figure 2). Take care not to damage the centering bushings as they will be reused with the new intake bolts.

Note: If the manifold is modified on the motor, plug the injector bosses to prevent debris falling into the motor.



Figure 1a



Figure 1b

FUEL RAIL INSTALLATION (3 AND 4-BOLT THROTTLE BODY INTAKE MANIFOLD)

1. Preassemble the rail brackets with the spacers and centering bushing. Coat the ends of the bolts with thread sealant.
2. The angled end of the bracket is always facing to the left when installed correctly on either side of the engine (Figure 3).

NOTE: The spacers for the 4-bolt intakes are slightly longer than the 3-bolt spacers.



Figure 2

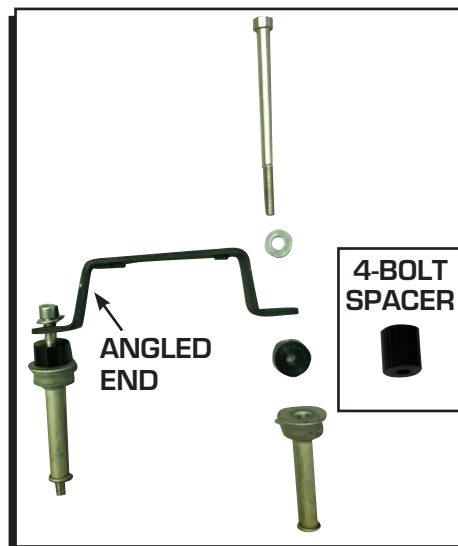

Figure 3 3-Bolt and 4-Bolt Intake Configuration.

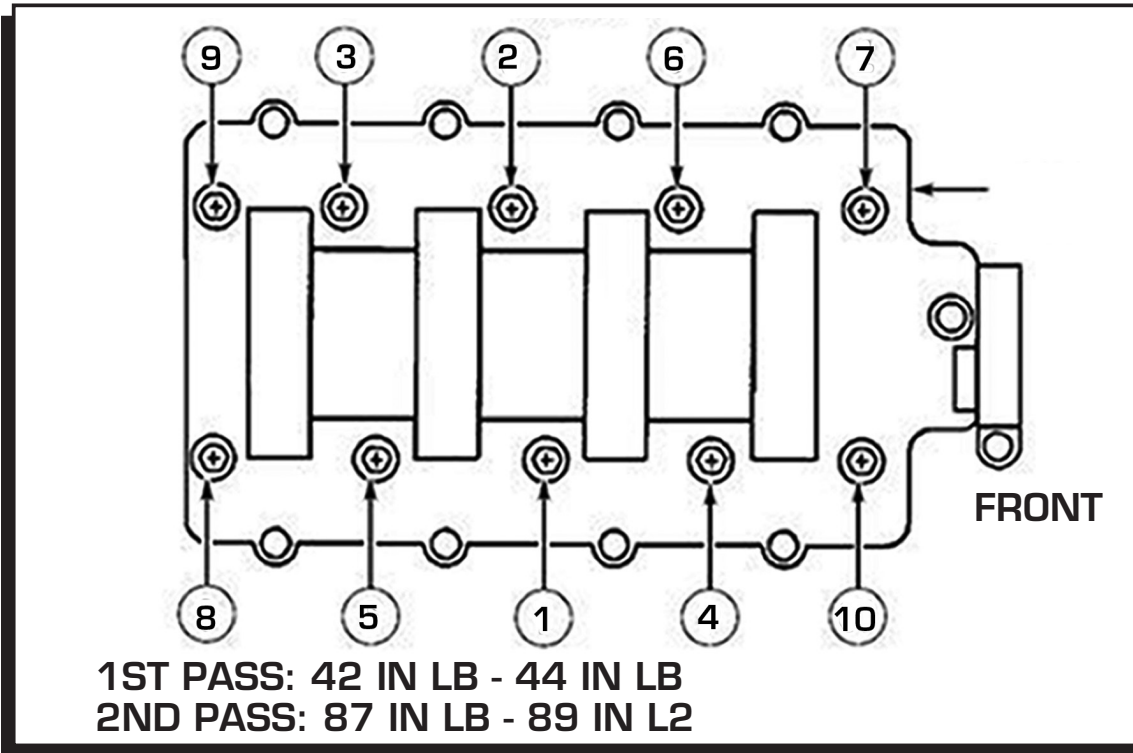

Figure 4 Intake Manifold Torque Specifications.

3. One of the fuel rails is shorter than the other. The shorter rail is installed on the driver side of the engine (Figure 5).
4. Lubricate the o-rings on the injectors with some motor oil or silicone lubricant. Install the clips onto the injector before they are pushed into the fuel rail bung. The injector clip will automatically secure the injector to the rail.
5. Push the fuel injectors into the bung without forcing them on. The injectors should slide in easily (Figure 6).
6. Plug the fuel injector pigtails into the fuel rail connections (Figure 7).
7. Connect the fuel injector pigtails into the injectors. The long wires connect to the injectors on each end of the fuel rail. The short wires connect to two inner injectors (Figure 8).
8. Plug the FPS (fuel pressure sensor) connector into the fuel pressure sensor under the fuel rail (Figure 9).
9. Connect the CAN cable from one rail to the other (Figure 10).
10. Connect the heavy red Rail Power wire together between the two rails (Figure 11).
11. Repeat steps 3-6 for the passenger side fuel rail assembly.

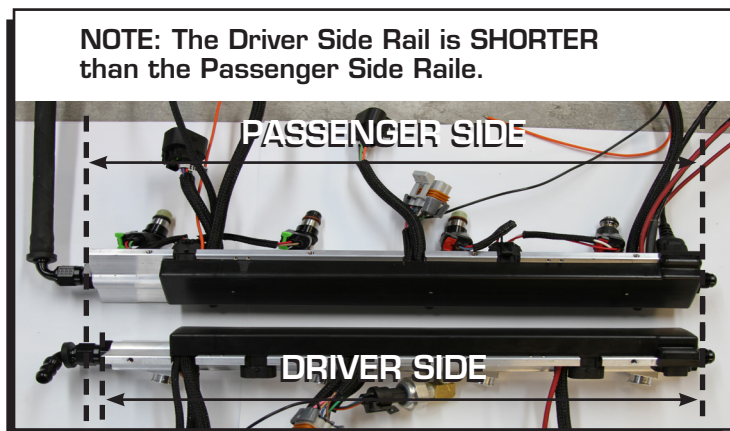

Figure 5 Fuel Rail Length.

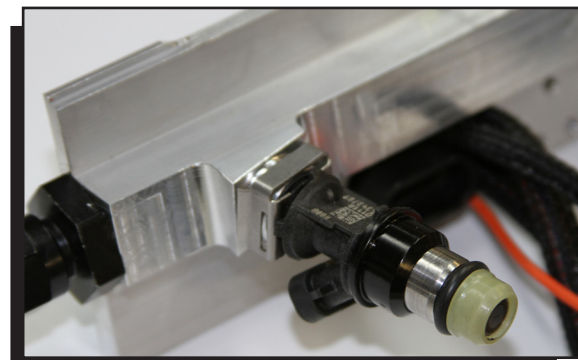

Figure 6 Injector Clips.

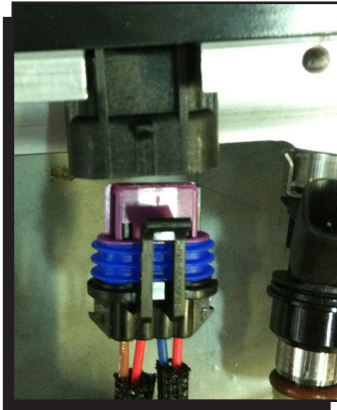

Figure 7 Injector Rail Connection.

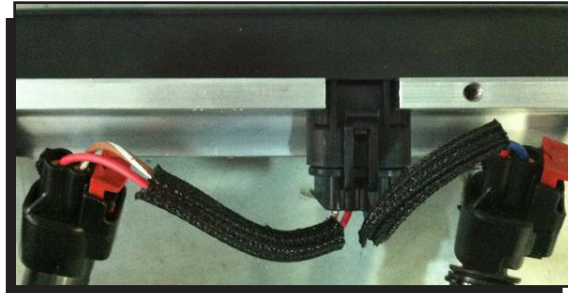

Figure 8 Injector Pigtail.

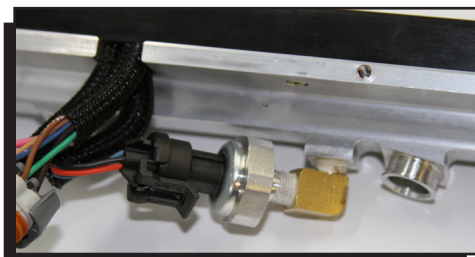

Figure 9 Fuel Pressure Sensor.

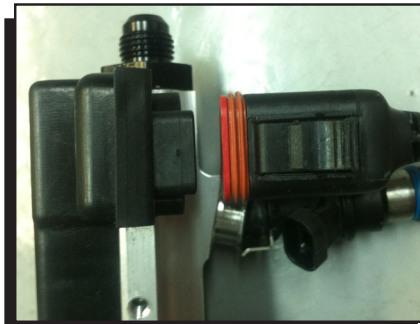

Figure 10 CAN Cable.



Figure 11 Rail Power.

12. Place the spacer/bushing/rail bracket assemblies onto the intake manifold.
13. Use the torque sequence on page 4, Figure 4 to torque the manifold bolts down correctly. Bolts #9 and #10 will use the stock length bolts/bushings.
14. Check the rail brackets with a straight edge (Figure 12).
15. Install the rails onto the manifold. Use the supplied 6mm bolts to secure the rails to the rail brackets. Torque to 85 in lb – 87 in. lb. (Figure 13).
16. **STOP.** Visually inspect and ensure all the injectors are sitting evenly and the injector o-rings are not pinched or visible. **Failure to install the injectors correctly can result in fuel leaks and engine fire.**
17. Begin routing the sensor harnesses and plugging them into the appropriate sensors.
18. Line the end of the fuel rail cover up with the edge of the black mold on the rear of the fuel rail (Figure 14). Slide the cover towards the rear of the engine to engage the locking tabs on the fuel rail. (Figure 15).

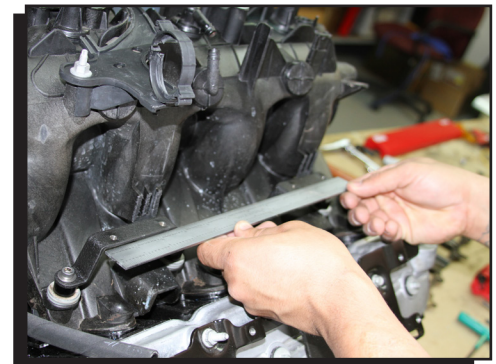

Figure 12 Straight Edge Check of Brackets.

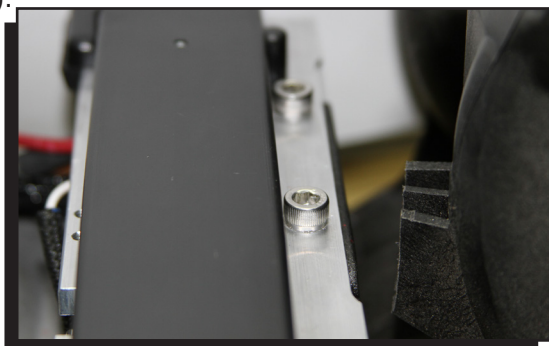

Figure 13 Rail to Bracket Bolts.

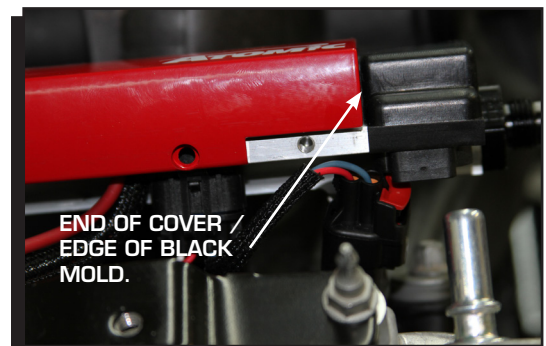

Figure 14 Fuel Rail Cover.

19. Secure the rail covers onto the fuel rail with the supplied 8/32 socket head cap screws (Figure 15).
20. Install the fuel rail end cap onto the cover and secure it with the supplied 6/32 socket head cap screws.



Figure 15 Fuel Rail Cover.

FUEL RAIL COVER INSTALLATION OVERVIEW

Follow these steps to install both covers. To remove the covers reverse the steps.

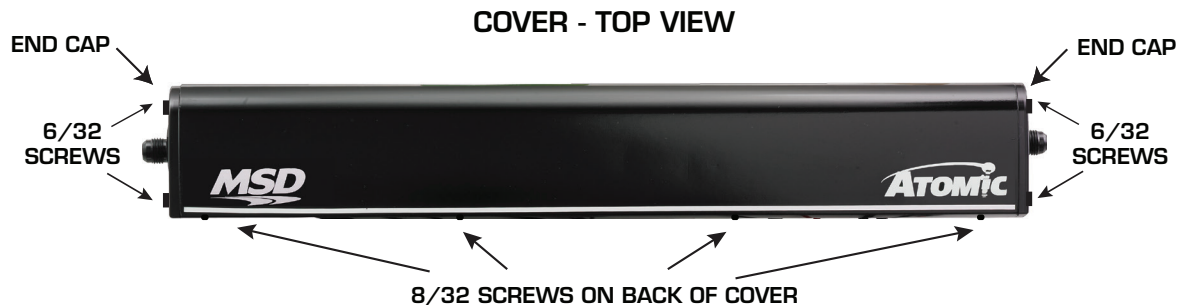

1. Line the end of the fuel rail cover up with the edge of the black mold on the rear of the fuel rail (Figure 14).
2. Slide the cover towards the rear of the engine to engage the locking tabs on the fuel rail.
3. Install the 8/32 screws that secure the covers to the fuel rails.
4. Install the end caps and secure with the 6/32 screws.

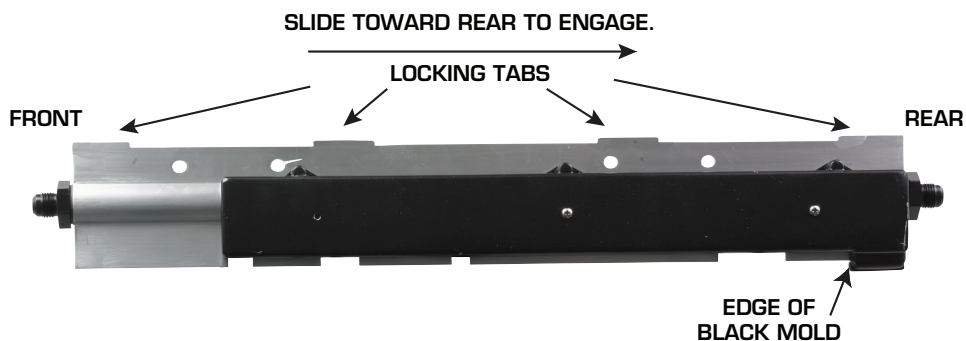

FUEL RAIL/ECU WIRING

The Atomic LS Truck kit has several adapter harnesses in order for the kit to install with all the different variations of the truck motors. These adapter harnesses plug into the connectors found on the rails themselves. The IAC and TPS connectors are on both rails to accommodate the different throttle body configurations.

Air Conditioning kick up (AC): When 12v is applied to this wire, the ECU will kick up the IAC count and Fan #1 to compensate for the engine load change created by the air conditioning compressor.

Alternator: The kit is supplied with a harness that has two alternator connectors on one end. This is done to accommodate the two different alternator ends used by GM. Identify which connector is needed, and cut the other connector off. Use the heatshrink caps provided in the parts bag to seal the wire end.

Cam Sensor: The kit supports both the 1x and 4x cam sensors. The easiest way to identify the cam sensor on a stock engine would be by locating the sensor on the motor. The 4x sensor is mounted on the timing chain cover. The 1x sensor is located on the back of the motor.

Controller area network (CAN): The kit utilizes a CAN communication for wiring between the fuel rails, Power module and Handheld Monitor.

Crank sensor: The kit supports both the 24x and the 58x crankshaft trigger wheels. The easiest way to identify which crank trigger wheel is in the motor, remove the starter, crank sensor (behind the sensor), and look into the motor to identify the crank trigger wheel (Figure 16).

Engine Coolant Temperature (ECT) sensor: The engine coolant temperature is monitored by the ECU for fuel and ignition adjustments in closed loop operation.

Fuel Pressure (FP) Sensor: The kit includes a fuel pressure sensor which is already installed on the driver side fuel rail.

Idle Air Control (IAC) Sensor: The kit has a connector on each rail to accommodate different intake styles. The sensor only plugs into the driverside IAC connector.

Ignition Coils: The kit has a factory connector that will connect to the factory coil bracket harness on each valve cover (not supplied with the kit). There is an extra ground wire with each coil bracket connector that should be grounded to the back of each cylinder head.

Injectors: The kit supports following injector part numbers -

Delphi connector (Figure 17) :

GM:17113553 AC Delco:17113553
GM:17113698 AC Delco:17113698

EV6 connector (Figure 18):

GM:12574927 AC Delco:217-1563
GM:12613411 AC Delco:217-3411
GM:12250681 AC Delco:217-1621

The kit does NOT support the following flex fuel injector-

GM:12580426 AC Delco:217-1626

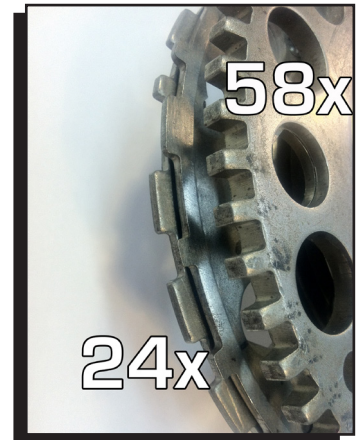

Figure 16 Crank Shaft Reluctors.



Figure 17 Delphi Connector.



Figure 18 EV6 Connector.

Intake Air Temperature (IAT) sensor: The sensor is supplied in the parts bag. It is recommended to install the sensor in the intake air track before the throttle body. A 3/4" hole is required for the sensor.

Map sensor: The kit supports the original equipment (OE) Delphi and Bosch sensors. A harness is supplied for each sensor.

Oil Pressure (Oil) sensor: The kit utilizes the factory oil pressure sensor. There are different style sensors, but the connector is the same between these sensors.

Power: The heavy gauge wire supplies 12v to both fuel rails from the power module.

Throttle Position (TPS) Sensor: The kit has a connector on each rail for the TPS sensor. This is done for ease of installation and only the driver side connector is used. The kit only supports a cable driven throttle body at this time and includes an adapter harness for the TPS sensor used on a cable driven throttle body.

Wide Band O2 Sensor: A wide band O2 sensor is supplied with the kit. The O2 sensor is used by the ECU to monitor air/fuel ratios (AFR) in the exhaust gases. Adjustments are made by the ECU in closed loop to maintain (AFR).

Variable Valve Timing (VVT): The kit supports the VVT system. Plugs into VVT Connector on the front of the timing chain cover in VVT capable engines.

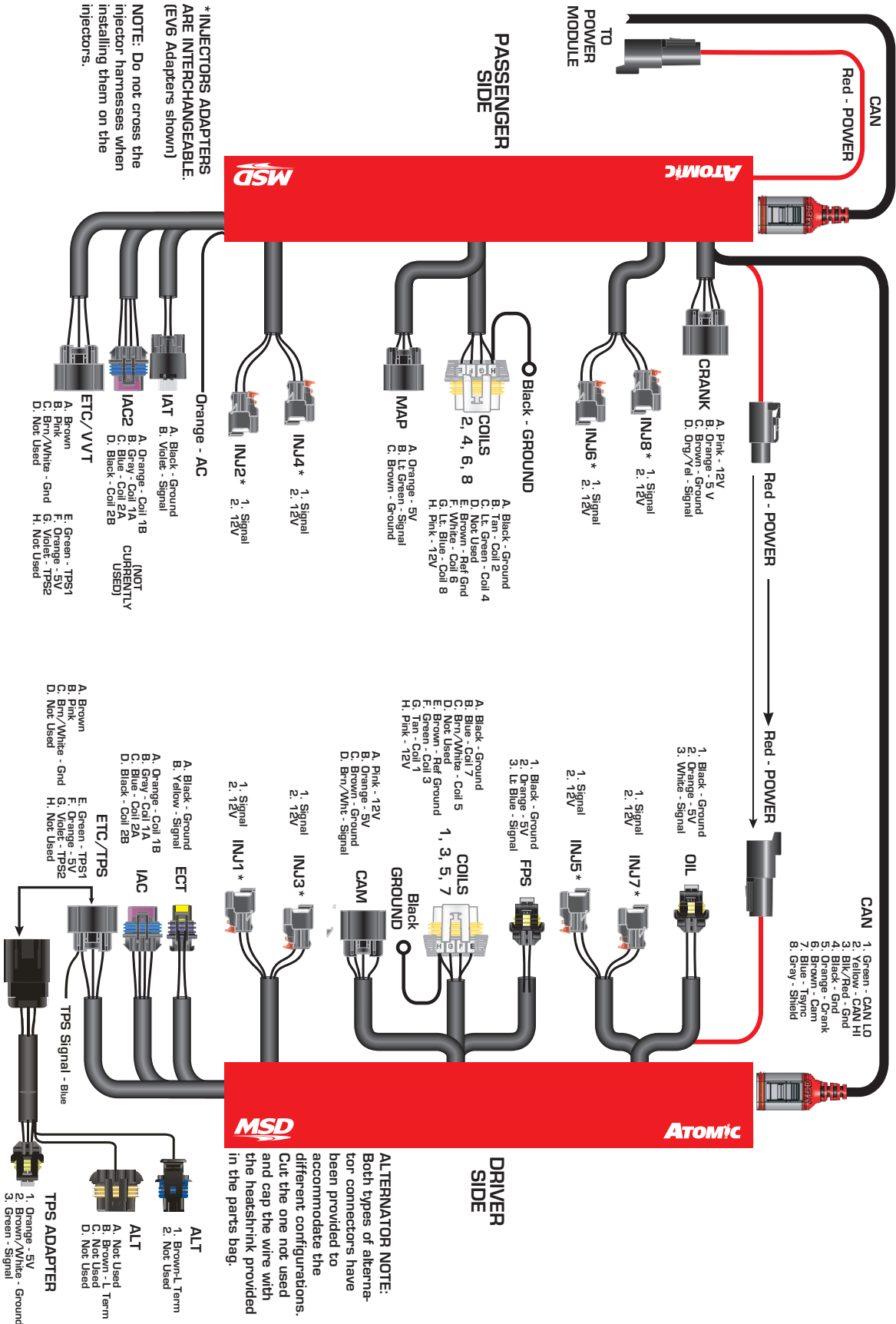

Figure 19 Wiring

POWER MODULE INSTALLATION

The Power Module of the Atomic EFI system handles high current circuits such as the fuel pump and WBO2. The unit has two ports for the MSD CAN system as well as a wiring harness. The CAN ports will provide communication between the Power Module, the passenger side fuel/ECU rail and the Handheld Monitor. It is important to select a proper mounting location for the Power Module. The unit can be mounted in the interior or the engine compartment as long as it is away from direct heat sources. It is not recommended to mount the unit in an enclosed area, such as the glove box. When a suitable location is found, make sure all wires reach their connections. Also be sure that the CAN port can be accessed for use with the Handheld Monitor. Use the Power Module as a template and mark the location of the holes. Use a size #20 drill bit to prepare a hole for the supplied self tapping screws. Assemble the sleeves in the power module (Figure 20).

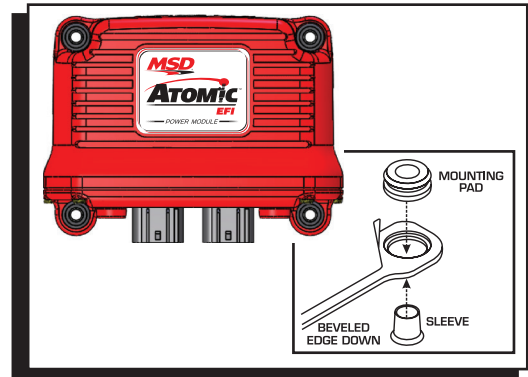

Figure 20 Mounting Hardware.

POWER MODULE WIRING (Figure 21)

Not all of the wires from the Power Module need to be connected for proper operation of the Atomic LS Truck kit. Some of the wires such as the nitrous input or electric fan controls, only need to be connected if their functions are being used. In the chart labeled Power Module Wiring, wires marked "REQ" must be connected for the system to operate while those marked "OPT" are optional depending on the features needed. For the initial installation and start up, it is recommended to connect only the required wires.

NOTE: The Power Module uses two heavy gauge (Red) wires that connect to the battery. Both leads must be connected in order for the Power Module and Atomic LS Truck kit to operate correctly.

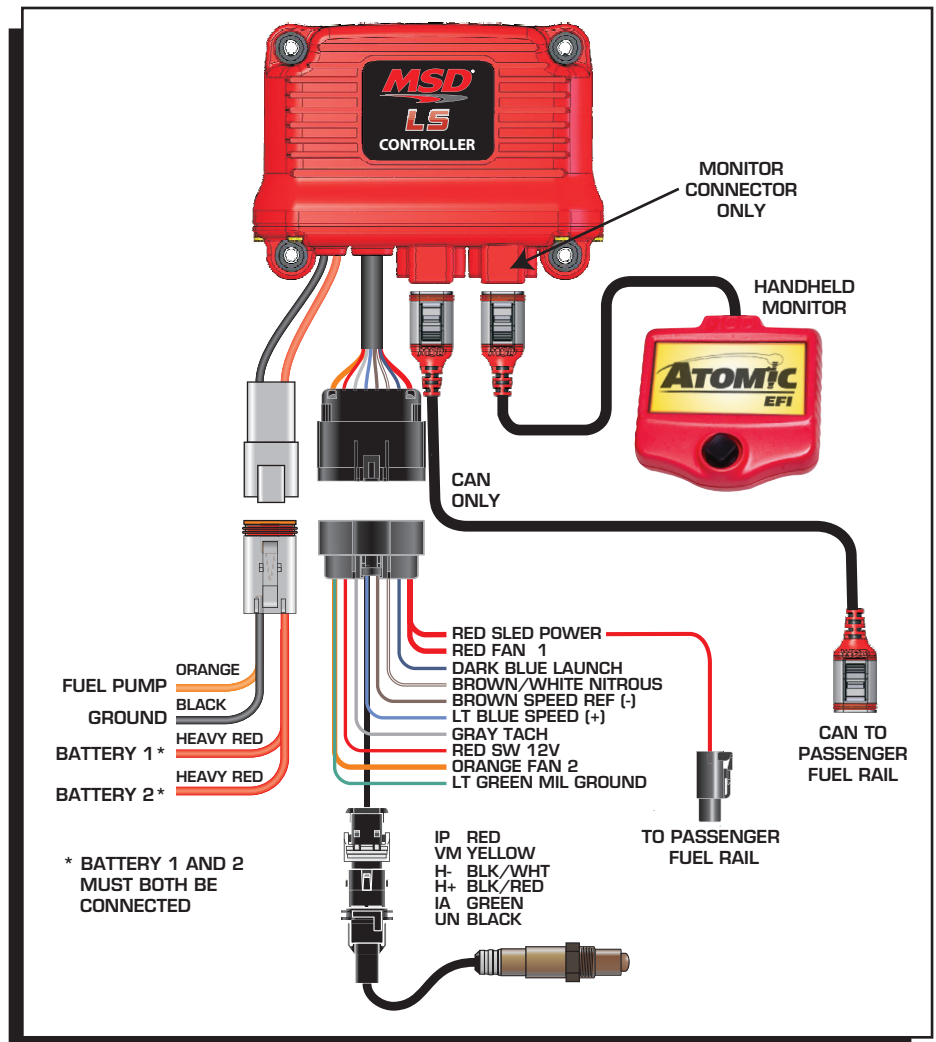

Figure 21 Power Module Wiring Diagram.

- Connect the CAN from the fuel rails into the center CAN port on the Power Module.
- Connect the Handheld Monitor to the CAN port on the Can Port on the right side of the Power Module.
- Connect the 16-pin GT connector harness included in the kit.
- Connect the 4-pin Deutsch connect harness included in the kit.
- Connect the wideband O2 sensor included in the kit.
- Make all the necessary electrical connections.

Power Module

CONNECTOR Deutsch 4-Way	Pin	Color	Use	Function	
	1	Red	REQ	Battery 1, Must be connected to Positive (+) Battery terminal.	
	2	Black	REQ	Ground, Connect to solid, clean engine ground.	
	3	Orange	REQ	Pump, Connect to Fuel Pump Positive terminal.	
	4	Red	REQ	Battery 2, Must be connected to Positive (+) Battery terminal.	
CONNECTOR GT Series 16 Way	A	Red	OPT	Fan 1, Supplies ground to activate Fan 1	
	B	Blue	OPT	2 Step Connect to switched 12V to activate.	
	C	Bro/Wht	OPT	Nitrous, When supplied with 12 volts, timing will be retarded and the air/fuel ratio will be corrected to the target nitrous setting.	
	D	Brown	OPT	Speed Ref. (-)	
	E	Lt Blue	OPT	Speed Signal (+)	
	F	Gray	OPT	Tach, Supplies 12V square wave signal	
	G	Red	REQ	Switched 12V, Connect to ignition switch	
	H	Orange	OPT	Fan 2, Supplies ground to activate Fan 2 at desired temperature.	
	J	Red	REQ	Supplies power to the Fuel Rail	
	K	Red	REQ	WBO2	IP
	L	Yellow	REQ		VM
	M	Blk/Wht	REQ		H-
	N	Blk/Red	REQ		H+
	P	Green	REQ		IA
	R	Black	REQ		UN
S	Lt Green	OPT	MIL Ground		This wire functions as a Malfunction Indicator Lamp (MIL). This wire will provide a ground in the event of a diagnostic code.

Sleds

Wire	Function
(2) Black wires w/ring lugs	Coil ground wires that should be attached to the cylinder heads.
(1) Orange flying Lead	A/C kick up wire. This should be wired to a source that gets 12V then the A/C compressor clutch is engaged. This will open the IAC up slightly and will also kick on fan #1 regardless of coolant temperature.

FUEL SYSTEM REQUIREMENTS

The Atomic LS fuel injection system requires a high pressure fuel pump system. The fuel system is not supplied due to the large variety of applications incorporating the LS engine platform. Depending on the engine combination, the Atomic LS requires a minimum of 58-62 psi continuous to operate. When selecting a pump, regulator and lines, be sure each component is designed to perform at high pressure. MSD offers fuel pumps, fuel hose and accessories to complete the installation. The following guidelines are intended to help set up a fuel system for the Atomic LS. The Atomic is capable of operating with a return or returnless style system.

- When running a returnless fuel system (Pulse Width Modulated) the fuel pump must be mounted in the tank. This will result in quieter operation, a reduction in pump temperature, and a less likely chance of fuel pump cavitation.
- MSD supplies -6 AN clamp-style fittings for the fuel rails. These fittings must be used with MSD's high pressure EFI hose.
- If mounting the pump in the tank is not an option, install the pump as close as possible to the tank. Mounting low to tank within 2-feet of sending unit is recommended. MSD recommends the Atomic Fuel Pump, PN 2925 or PN 2926.

- When using a PWM fuel system, pulsations and harmonics could cause unstable fuel pressure that can result in fuel pump cavitation or poor engine performance. For this reason MSD does not recommend the use of a hard line for the fuel system in PWM mode.

Note: Ensure Fuel Pump is PWM capable.

FUEL SYSTEM INSTALLATION

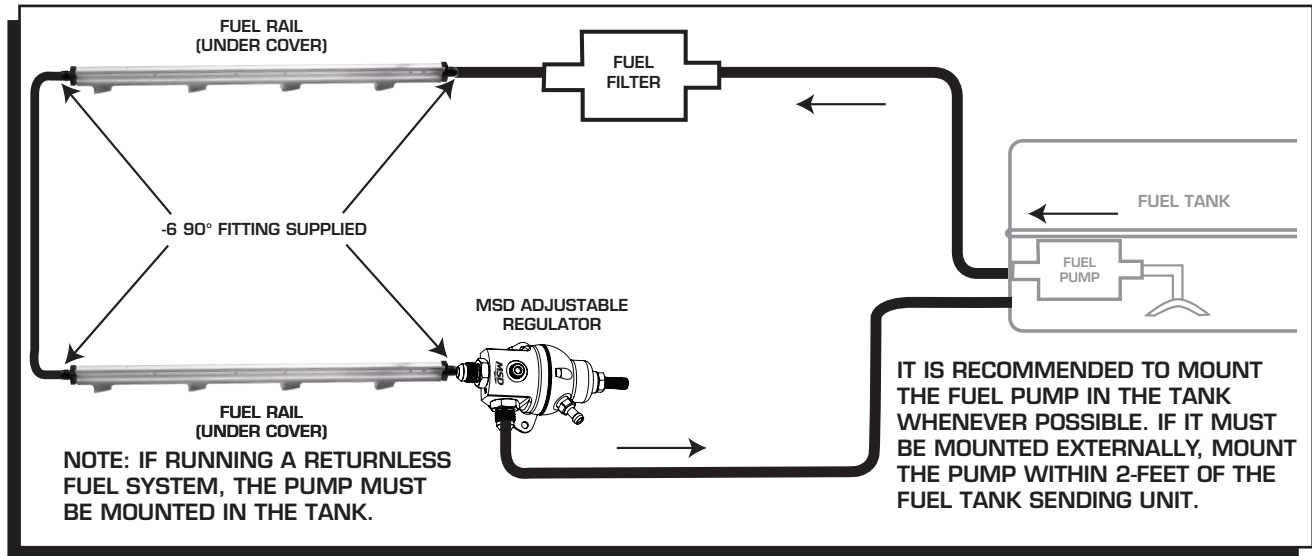

Figure 22 Fuel Line Routing.

IN-TANK PUMPS

The MSD Atomic Fuel Pump (not supplied) can be used in the tank however it would require a sock, or filter element on the pickup side of the pump. It is important to note that the wiring used to run the pump will need to meet requirements to be submersed in fuel. When wiring an in-tank pump, it is recommended to use a wire that conforms to SAE specifications J1128 and J378. This wiring features a Thermoplastic insulated wiring with polyvinyl chloride insulation for protection against gasoline, oil, and more. In addition, different fuel line will be required internally if the pump is to be mounted in the tank. Fuel line that meets SAE 30R10 specifications MUST be used. Failure to do so will cause severe damage to your engine and/or fuel system.

WARNING: Improper installation or use of fuel system components can cause severe damage your engine and/or fuel system that will not be covered by the manufacturer’s warranty.

Atomic Fuel Pump, PN 2925: This pump features 3/8” inlet and outlet. The pump will support approximately 525 hp and is approved for in-tank use (no wiring or in-tank mounting hardware/pickup element are supplied).

Fuel Pump Kit, PN 2920: This Kit is supplied with MSD’s PWM Fuel Pump, a pre and post-filter, 15-ft of 3/8 fuel injection line and mounting hardware.

Fuel System Return Kit, PN 2922: If you plan on running a return line with your Atomic LS, this kit provides another 15-ft of 3/8” injection line, an MSD Regulator and -6AN-to-hose fittings.

High Horsepower Fuel Kit, PN 2921: This pump will support the power demands of engines up to 650 horsepower. The pump features 3/8” inlet and outlet. The pump will support approximately 650 hp and is approved for in-tank use (no wiring or in-tank mounting hardware/sock are supplied).

Fuel Inlet Fittings and Cross-Over Line: LS engines require a cross-over fuel line to route the fuel from one bank to the other. This is typically done at the front of the engine. (Figure 23) Due to the variety of intake manifolds and accessories, a cross-over line must be made for each application

MSD supplies a length of fuel hose and two 90° -6AN fittings to prepare a fuel crossover line. The fittings are designed for use with the supplied hose and clamps.

Proper installation begins with a clean, square cut of the hose. A hose cutting tool or a new razor blade are recommended. When installing the hose, it is important that the hose is pushed all the way to the backstop. The clamp must be centered between the fitting rib and the backstop before it is tightened.

1. Determine the length of hose needed. Mark the hose and cut it using a hose cutter or new razor blade. There should be minimal disturbance of the jacket and braids. The cut plane should be perpendicular to the hose axis (Figure 24).
2. Before installing the hose to the fitting, it is important to anchor the fitting (Figure 25). Proper installation may be difficult when holding the hose and fitting with your hands. For best results, the hose should be installed with minimal twisting or pausing.
3. Apply a light coating of oil to the rib on the fitting. Use care not to get oil on the outside of the hose as it will be impossible to maintain a grip on the hose.
4. With the fitting anchored securely, push the hose over the fitting until it bottoms against the backstop. Center the clamp between the rib and backstop before tightening (Figure 26).

WARNING: The supplied MSD AN Fittings are designed only for use with the supplied fuel hose. We do not recommend mixing fittings and hoses from different manufacturers. Doing so may result in fuel leaks and expose other dangerous incompatibilities.



Figure 23 Installing Fuel Hose to AN Fittings.



Figure 24 Severing the Hose Properly.

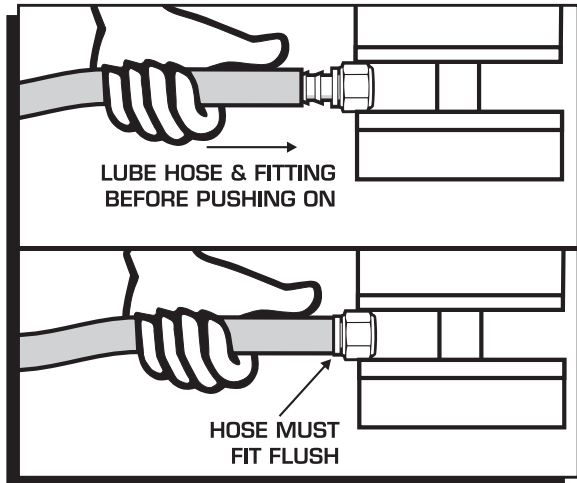

Figure 25 Installing Fuel Hose to the Push-Lock Fittings.

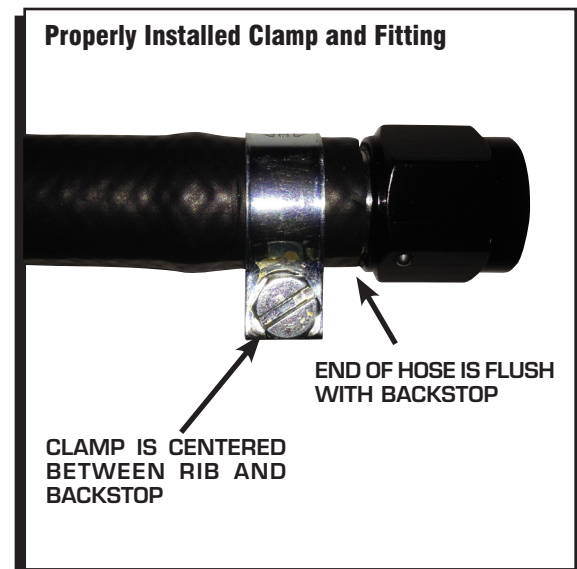

Figure 26 Installed Fitting and Clamp.

WIDE BAND OXYGEN SENSOR INSTALLATION

The MSD Atomic EFI system requires a single Wide Band Oxygen Sensor (WBO2) for operation. MSD suggests that the bung for this sensor be installed prior to starting any other part of the conversion process. By having the WBO2 in place first, there is a reduced chance of the vehicle being immobilized for an extended time. The bung for the WBO2 provided by MSD has a plug included so that the vehicle can be driven between the time of exhaust modification and installing the rest of the Atomic system, if needed.

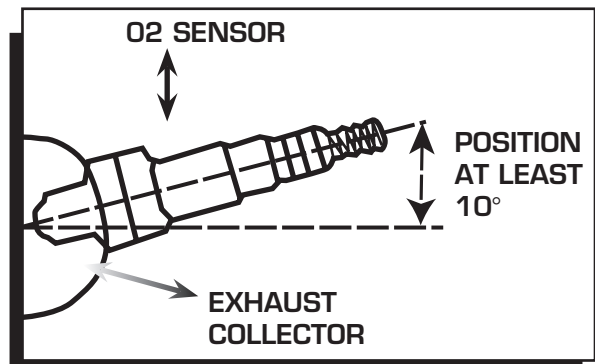

Figure 27 WBO2 Sensor Location.

The WBO2 can be installed in either exhaust bank. The sensor connects to the Power Module, so install the sensor on the bank closest to where you plan to mount the Module. The bung should be installed by a qualified exhaust technician and pressure tested. Proper installation of the oxygen sensor is critical to the performance of the Atomic EFI. Improper installation could lead to engine damage.

1. Locate the ideal spot to install the WBO2.
 - a. This location should be 2-4 inches after the exhaust collector. The sensor must be more than 18 inches forward of the exhaust tip. For applications where short or open headers are used, install the WBO2 in the primary tube of the rear cylinder at least 8 inches away from the exhaust port. The Atomic will not work on "Zoomie" style headers.
 - b. The WBO2 sensor should be at least 10° above horizontal to allow condensation runoff. Without this angle the sensor is significantly more likely to sustain water damage (Figure 27).
 - c. Never place a WBO2 on the outside of a bend.
 - d. The WBO2 must be mounted in the exhaust prior to any catalytic converter, if applicable.
2. Drill a 7/8" hole in the exhaust where the WBO2 will go.
3. Weld in the supplied bung. Ensure the weld goes completely around the bung and is air tight.
4. Insert supplied plug in bung. Never run the vehicle with a WBO2 installed but not plugged in to the harness and powered up; it will damage the sensor.
5. When completing the Atomic EFI installation, remove the plug and insert the WBO2 for use. MSD suggests using a small amount of anti-seize on the threads.

Note: The Atomic EFI is extremely sensitive to air leaks in the exhaust system. Any air leak between the engine and the WBO2 will cause the Atomic to have false readings, which can lead to poor engine performance, misfires, and an inability to properly auto-tune. Extended running of the Atomic EFI with an exhaust leak can result in detonation and severe engine damage. Improper installation of the oxygen sensor, and any damage that may result from such an installation, is not covered by the manufacturer's warranty.

WARNING: DO NOT ATTEMPT TO START THE ENGINE. Before turning the ignition key to the ON position, confirm all fuel line connections are tight and all electrical connections are correct. After confirming all electrical connections and fuel lines, turn the ignition key to the ON position. Check every hose and fitting connection for any signs of fuel leaks. The Handheld screen should illuminate and display the Main Menu.

PROGRAMMING

The Handheld Monitor plugs into the Power Module via the CAN connection. It can be removed once the initial setup is complete, or can remain connected for use of features such as the dash or digital gauge displays. The Handheld Monitor features a joystick to scroll through the settings. Scroll up and down to the setting and push the joy stick to the right to select the options. When the selection is made, either push in, or go back (push to the left) to save/confirm settings changes.

MAIN MENU

Six selections will come up the Monitor under the Main Menu. If this is the first time powering up the Atomic LS, select Initial Setup (Figure 28).

Atomic LS Dash: This selection allows you to view a variety of engine functions in real time when the engine is running. Refer to page 21 for a complete description of each parameter in the Atomic Dash.

Atomic LS Gauges: This setting puts five important values in gauge form to ease viewing the data. This includes engine rpm, oil pressure, engine coolant temperature, speed (when connected), battery voltage, and air/fuel ratio.

Initial Setup: These are values that are required to start the engine.

Advanced Setup: Optional settings for features and optimized drivability settings.

Diagnostics: This screen will help you troubleshoot and identify potential issues.

Display Setup: Provides adjustments for the appearance of the monitor screen. See page 20 for more information.

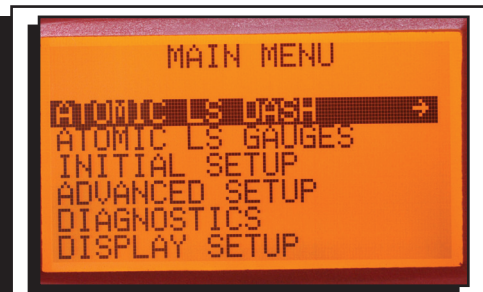

Main Menu

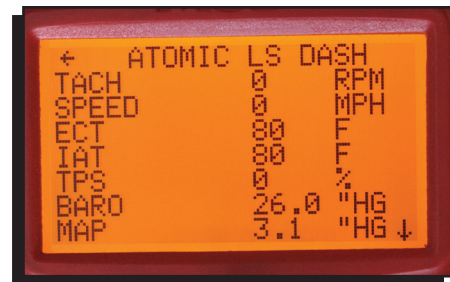

Atomic LS Dash

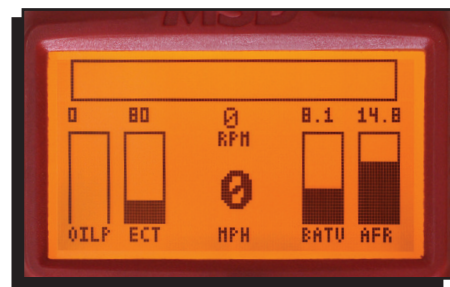

Atomic LS Gauges

Figure 28 Monitor Main Menu

INITIAL SETUP PROGRAMMING

Scroll down to Initial Setup and push the joystick to the right. The following parameters must be programmed.

Engine Type: This value determines the engine platform (Figure 29). There are over 26 engine combinations to select from. This setting is important as once an engine type is programmed, other settings will default to the OEM components that were supplied on that engine. For example, if LQ4 is selected, the coil, injector and MAP sensor will automatically set to the OEM components.

Engine Size: Once the engine type has been selected, the stock cubic inches will automatically be set. If the engine has been modified with a different stroke or bore, select and input the size. The range is from 100-800 cubic inches (Figure 29).

Camshaft Type: There are three cam selections to choose; Street/Stock, Mild and Performance. Note that if the lobe separation angle (LSA) is less than 108°, it is recommended to input the next larger cam. Cams with over 250° are not recommended for use with the Atomic LS system (Figure 29).

CAM	DURATION AT .050"
Street Stock	Less than 210°
Mild	211° - 230°
Performance	231° - 250°

Coils: Once the engine type is selected, the OEM coil pack will be automatically loaded in the default calibration file. If a different coil or an MSD LS Coil pack is used, change the setting to the correct coil type (Figure 29).

Note: There is a setting in Display Setup labeled User Mode. When User Mode is changed from Basic to Advanced, the coil selection menu will open up to all the coil combinations preprogrammed into the Atomic LS system.

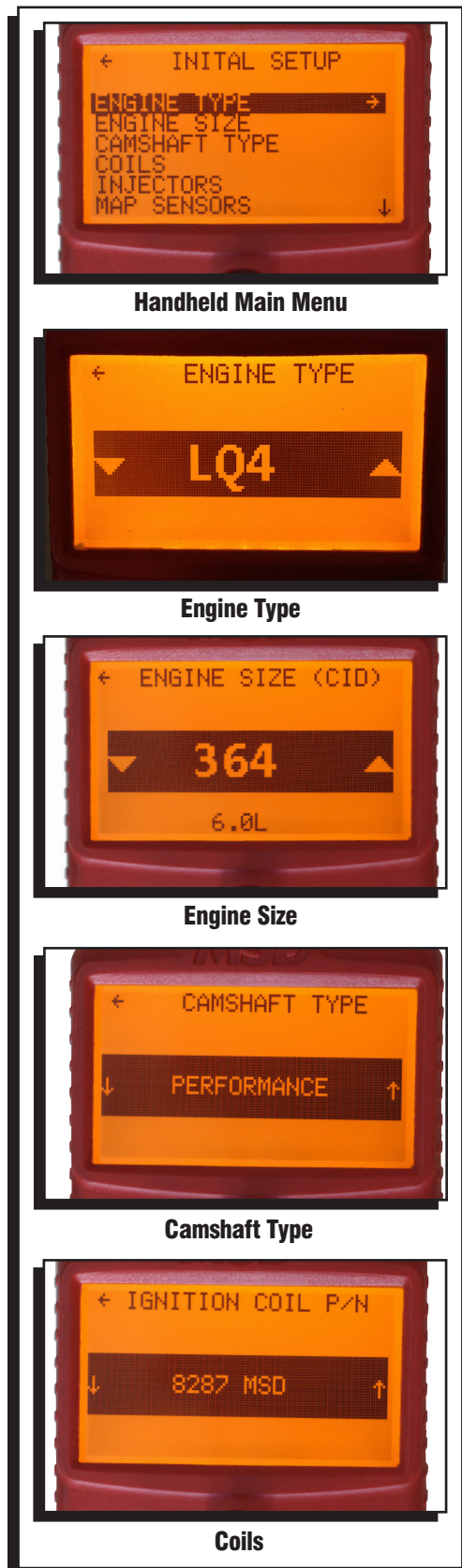

Figure 29

Fuel Injector: Once the engine type is selected above, the OEM style injector will be automatically loaded in the default calibration file. If a different injector is used, change the setting to the correct injector. Most LS based injectors have the part number stamped on them (Figure 30).

Note: There is a setting in Display Setup labeled User Mode. When User Mode is changed from Basic to Advanced, the fuel injector selection menu will open up to all the fuel injector combinations preprogrammed into the Atomic LS system. This setting will also unlock a setting called User Defined. User Defined allows the injector flow rate to manually be entered by selecting Set Calibration (Figure 30).

MAP Sensor: Once the engine type is selected above, the OEM MAP Sensor will be automatically selected. (Figure 30).

Note: There is a setting in Display Setup labeled User Mode. When User Mode is changed from Basic to Advanced, the MAP sensor selection menu will open up to all the MAP Sensor combinations preprogrammed into the Atomic LS system. This setting will also unlock a setting called User Defined. User Defined allows the Slope and offset to manually be entered by selecting Set Calibration.

Fuel Pump Type: There are three selections for the fuel pump system. Select the system in use with the Atomic LS Truck system (Figure 30).

- **Pulse Width Modulated:** This selection is used only when running a returnless fuel system with NO regulator.
- **Non-PWM with Regulator:** This selection is used when running a return style system with a regulator.
- **PWM with Regulator:** This selection is used when running a return style system with a regulator. It will run the pump at 50% duty cycle at idle producing quieter pump operation and will increase the duty cycle to 100% as the throttle and injector load increase.

Note: It is recommended to use Non-PWM with a regulator when setting fuel pressure as the PWM setting may decrease fuel pressure slightly at idle.

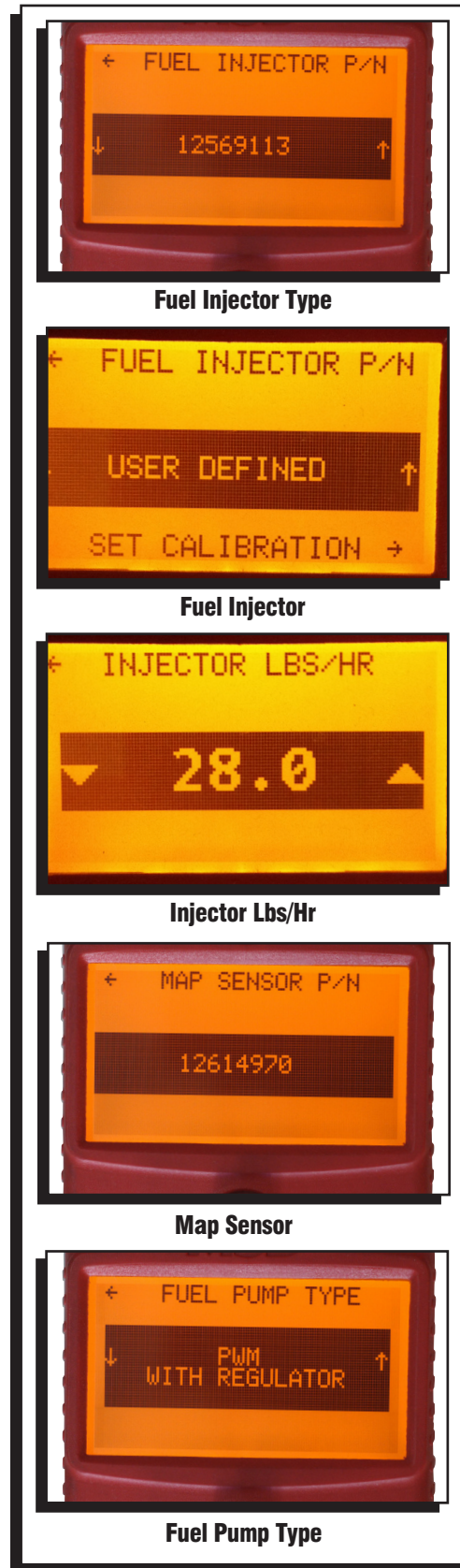

Figure 30

Idle RPM Target: Select the rpm that the engine should idle at. The rpm range is adjustable in 25 rpm increments (Figure 31).

Note: Running too high of an idle speed in an automatic transmission equipped vehicle with a stock torque converter can cause idle issues in gear. The IAC counts should be set at approximately 10-30 in neutral with the engine warmed up, running and the A/C off. This is done by opening or closing the throttle blade. It must be set after the commanded idle is entered here.

Rev Limit: The rev limiter can be set as a fuel cut-off or ignition cut-off limiter. The default setting is as a fuel cut-off limiter set at 6500 RPM. The programming range for both rev-limiters is 3000 RPM-10,000 RPM (Figure 31). The ignition cut should only be used on race vehicles with a very free flowing exhaust. **DO NOT use with catalytic converters or severe damage may result!**

Variable Cam Timing: The Atomic LS truck system supports the factory Variable Cam Timing. The default setting is set at Disable. Change the setting to Enable for use with a factory VVT engine (Figure 31).

Once all of the settings in the Initial Setup menu are selected, the Atomic has enough information to start and run the engine. It is recommended to scroll through the advanced settings to program selections that may be useful after the initial start up (such as the cooling fan activation temperatures).

ADVANCED SETUP

The Advanced Setup features are optional as the Initial Setup menu provides the Atomic EFI with the values needed to run the engine. Features in the Advanced Menu are designed to deliver additional features and advanced tuning functions to further enhance the drivability and overall performance of the engine.

Fans: This setting sets the temperatures to activate two electric fans. Each circuit will be activated by supplying ground through the Red (Pin A) and Orange (Pin H) wires of the GT-Series 16 pin harness from the Power Module. A relay is required for both circuits since those wires are a low current ground. The fans will activate at the desired temperature and will remain on until the temperature falls below 10° of the setting. Settings are 100°-300°F (Figure 31).

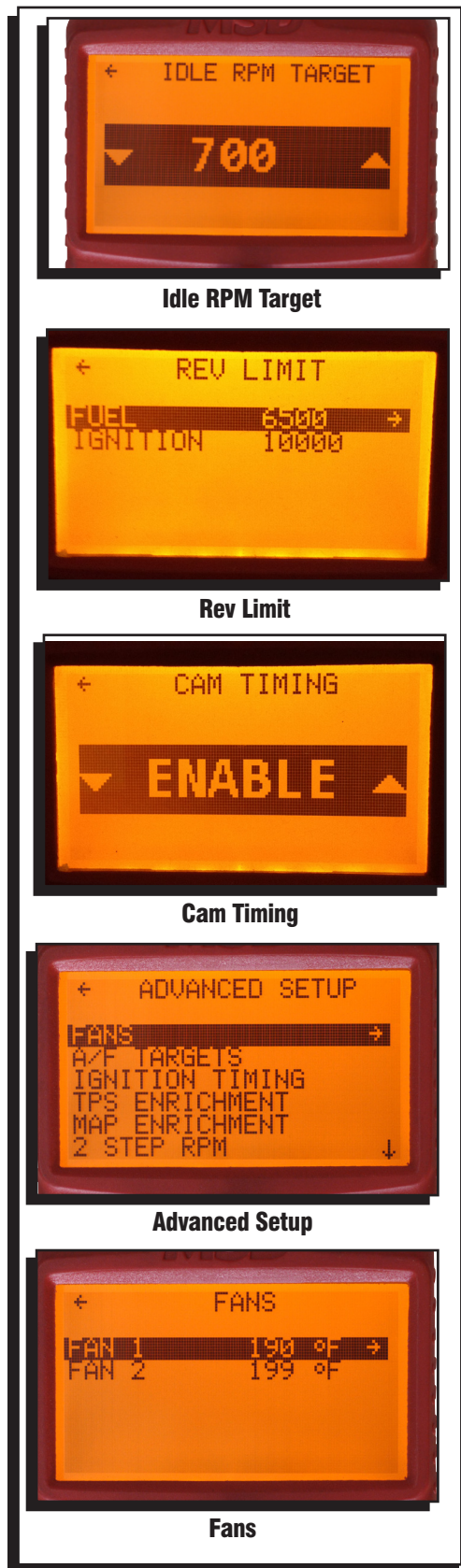

Figure 31

A/F Targets: The Atomic LS provides an option to set an air/fuel target for Idle, Part Throttle, Wide Open (WOT), Nitrous and Boost. The Atomic will use its self-learning technology to adjust the fuel delivery to meet the target air/fuel ratio. The values are adjusted in 0.1 increments and range from rich at 10:1 to dead lean at 16:1. The ideal air/fuel ratio for cruising is called stoichiometric and is commonly referred as a 14.7:1 air/fuel ratio.

Boost: The Atomic will switch to the commanded boost A/F ratio once the manifold pressure reaches 110Kpa (approximately 16 psia - 32.5in/Hg) (Figure 32).

Ignition Timing: The Atomic provides a base timing table for each engine application. You can also modify these settings at idle (closed throttle), part throttle, wide open throttle (WOT), nitrous, and boost. Each setting is adjustable +/-10°. Note that the values programmed are set for stock engines using 91 octane fuel. For lower octane fuels it is recommended to retard the timing 5° as a starting point. Timing can be retarded up to 20° in 0.1° increments. Note that in order to alter the timing for nitrous use, the Nitrous Selection in the Advanced menu **MUST** be programmed to ENABLE. When the nitrous is activated by supplying 12 volts to the Brown/White (Pin C) wire the timing will retard (Figure 32).

TPS Enrichment: To assist in throttle transitions the Atomic EFI has a feature to increase fuel delivery by a prescribed percentage any time there is an increase in throttle position. If needed, make small changes in no more than 5% increments without further testing. Most engines will find 25% sufficient. Most applications will accept 15%-35% enrichment. Adjustable from 0-100% in 1% increments (Figure 32).

MAP Enrichment: To assist in manifold pressure transitions the Atomic EFI offers a MAP enrichment feature. This function adds fuel based on MAP transitions while moving the throttle. Large cam vehicles with low vacuum generally required a slightly smaller number while stock/small camshaft vehicles with a high vacuum may require more. If needed make small changes of no more than 5% increments without further testing, 25% is sufficient for most engines but between 15-35% is normal. Typically, the higher the vacuum the higher the percentage needed. Adjustable from 0-100% in 1% increments (Figure 32).

2-Step: This setting will rev-limit the engine at the programmed RPM when the Blue wire is activated with 12V. The 2-Step setting is used in drag racing applications to help launch the car at a constant RPM. The blue wire is normally connected to a clutch switch or a brake switch. The default setting is 10,000 RPM and can be adjusted from 1000 RPM to 7500 RPM in 25 RPM increments (Figure 32). The ignition cut should only be used on race vehicles with a very free flowing exhaust. **DO NOT use with catalytic converters or severe damage may result!**



A/F Targets

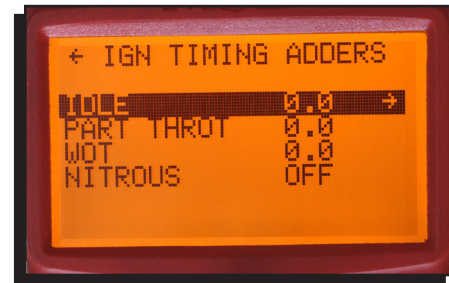

Igniton Timing

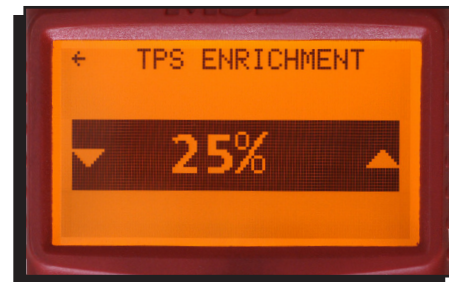

TPS Enrichment

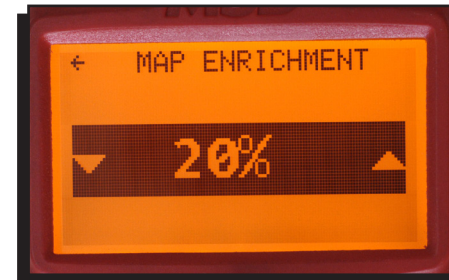

MAP Enrichment Setting



2-Step RPM Limit

Figure 32

Nitrous: This setting enables the nitrous timing retard in the Ignition timing and the nitrous AFR in AF Target setting. The default setting is DISABLED (Figure 33).

Calibrate Speed: If there is speed output on the transmission, a reference signal can be delivered to the Atomic LS. On manual transmission equipped vehicles, the Calibrate Speed option improves drivability when transitioning from high RPM conditions to an idle (such as coming off of a hill / between moving and coming to a complete stop). The Power Module has a Brown (Pin D) wire and a Light Blue (Pin E) wire. These wires connect to a magnetic pickup monitoring driveshaft speed with a collar mounted on a yoke. To program the calibration, drive to 40mph on an open road to maintain speed. Once at 40mph, select YES on the handheld. This will calibrate the speed input. This option will also enable a speedometer reading in the handheld Atomic LS Dash (Figure 33).

Note: Use of a minimum four magnet collar is recommended with this option.

Racepak Dash: This setting allows the Atomic LS Truck kit to interface with a Racepak dash such as an IQ3. Disable is the default setting. Racepak offers an optional V-net sensor to connect their dash to the MSD Can-Bus connector (Figure 33).



Figure 33

PRE-START CHECK LIST

Before attempting to start the motor, run through the pre-start check list to ensure a safe and successful start.

- Double-check all wiring
- Power and ground leads are connected directly to the battery.
- Red (Pin G) should be connected to a 12v ignition source that is hot in the RUN and START positions of the key cycle.
- All wiring, modules, and fuel components are mounted away from heat sources such as exhaust and pinch points.
- Wideband O2 sensor is installed and plugged into the Power Module
- There are no exhaust leaks.
- The throttle linkage is connected and moves freely with no binding.
- The initial programming has been set in the handheld menu.
- Key on the ignition a few times to prime the fuel pump. The fuel pressure may need to be adjusted to 58-60psi. Fuel pressure can be monitored in the Atomic Dash section of the handheld menu.
- With the fuel system under pressure from priming the system, check for leaks or fuel spraying. Do not attempt to start the engine if fuel leaks are present.
- Monitor Engine RPM in the Atomic Dash in the handheld unit as the engine is cranked over to ensure the crank sensor is providing an RPM signal.

HANDHELD DISPLAY OPTIONS

Display Setup: The display Setup controls the look of the handheld unit and the Firmware version. The Atomic LS can be reset to factory default in this section as well (Figure 34).

LCD Contrast: Adjust the contrast on the LCD screen if it is hard to see the display. Contrast is adjusted using the joystick to go up or down in five percentage increments.

Backlight Level: The brightness of the screen is determined by this setting. The Backlight Level may need to be adjusted depending on outside light levels. Brightness is adjusted using the joystick to go up or down in five percentage increments (Figure 34).

Display Units: The Atomic can display items in either English (cubic inches, Fahrenheit) or Metric (liters, Celsius). **Set Atomic Defaults:** Use this feature to reset the Atomic EFI. Selecting "YES" on this screen will take all setting, including fuel maps, back to the factory defaults. This can be done when installing the Atomic on a different engine, or for troubleshooting reasons (Figure 34).

User Mode: This setting can be changed from Basic to Advanced. When the User Mode setting is changed to Advance the fuel injector selection menu, coil selection menu, and the MAP sensor menu will open up to all the combinations preprogrammed into the Atomic LS system. The fuel injector flow rate and MAP sensor Slope and Offset can be manually entered by selecting user defined in the selection menu (Figure 34).

Set Atomic Defaults: This setting resets all the programming parameters to the default settings out of the box (Figure 34).

Firmware Versions: The Atomic Firmware version can be found in this section (Figure 34).

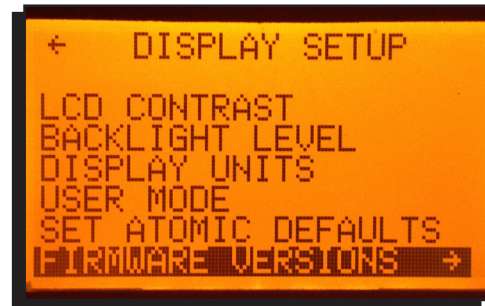

Figure 34 Monitor Display Selections.

The Atomic LS Dash is a live display when the engine is running. This is a brief description of each parameter in the Atomic LS Dash.

ATOMIC LS DASH:	
Tach	Displays engine RPM.
Speed	Displays Speed if speed sensor is equipped and calibrated.
ECT	Displays coolant temperature.
IAT	Displays intake air temperature.
TPS	Displays throttle position sensor percentage.
BARO	Displays barometric pressure
MAP	Displays manifold absolute pressure
FUEL PRESS	Displays fuel pressure.
OIL PRESS	Displays oil pressure.
BAT VOLTS	Displays battery voltage.
A/F RATIO	Displays air/fuel ratio.
INJ DUTY	Displays injector duty cycle.
IGN TIMING	Displays ignition timing.
IAC POS	Displays idle air control motor position.
THROTTLE	Displays throttle condition closed/part/WOT (Wide Open Throttle)
CLOSED LOOP	Displays closed loop on or off.
LEARNING	Displays Atomic LS learning on or off.
FAN 1	Displays Fan 1 on or off.
FAN 2	Displays Fan 2 on or off.
DECEL FUEL	Displays if decel fuel is active
IDLE COND	Displays if engine is in an idle condition
FLOOD CLEAR	Displays if throttle is in a flood clear condition (no fuel will go in)
REV LIMIT	Displays if the rev limiter is active
TWO STEP	Displays if the two step is active.
NITROUS	Displays if the nitrous is active.

DIAGNOSTICS

There is a self-diagnosing system built into the Atomic EFI. Each covered parameter can show a status in one of three ways (Figure 35).

- “OK”: the parameter is functioning normally.
- “Error C”: there is currently an error occurring.
- “Error H”: A previous error that has been reset since it did not reoccur within the last ten ignition cycles.

The following chart gives the most likely solution(s) to each possible error.

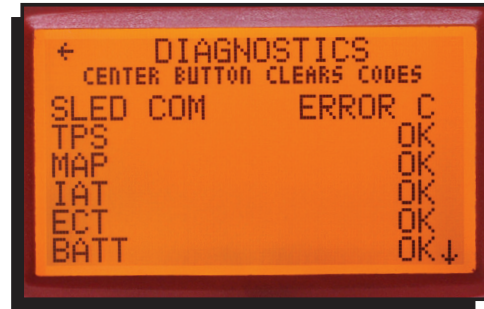

Figure 35

CLEARING HISTORY ERRORS

CODE NAME	WHAT IT MEANS	PROBABLE CORRECTION(S)
TPS	There is no reading for the Throttle Position Sensor.	The sensor may be at fault. Check wiring and/or replace sensor.
MAP	There is no reading for the Manifold Absolute Pressure Sensor.	The sensor maybe at fault. Check wiring and/or replace sensor.
IAT	There is no reading for the Inlet Air Temperature Sensor. The ECU will default to 275°F when shorted or -40°F when open.	Faulty sensor; loose or no connection. Check wiring and/or replace sensor.
ECT	There is no reading for the Engine Coolant Temperature Sensor. The ECU will default to 275°F when shorted or -40°F when open.	Faulty sensor; loose or no connection. Check wiring and/or replace sensor.
BATT	The Atomic is receiving the wrong voltage. The unit is measuring either less than 9 volts or greater than 16 volts.	Check the battery connection from the Power Module to the battery. Ensure that the battery and alternator are working correctly.
INJ DC	Excessive Injector Duty Cycle	If you are running a returnless fuel system, your engine's needs may exceed the Atomic's maximum capabilities. If you are running a return system check to see that you are maintaining the recommended fuel pressure. If you have adequate fuel pressure the engine's needs may exceed the Atomic's system capabilities.
FUEL PRESSURE	There is no reading for the Fuel Pressure Sensor.	Faulty sensor; loose or no connection. Check wiring and/or replace sensor.
WBO2	A. "NOT CONNECTED" indicates that no sensor is detected. B. "ERROR" indicates that the sensor has failed.	A. Check to see that the sensor is securely plugged into the system. Inspect wiring if it is plugged into the system. B. The sensor will need to be replaced. Note that 'warming up' is normal during start-up for the first 20 seconds.
FP CAV	This code will set if there is an issue with Fuel Pump Cavitation (similar to vapor lock). It can only set when running a returnless fuel system. This may occur when the commanded fuel pressure (from the ECU) is different than the fuel pressure (at the sending unit).	Check the fuel system and determine that it meets the requirements to run a returnless (PWM) system. Check the filters, the sock in the tank, and inspect the lines for any kinks or pinches that would affect the fuel flow and pressure of the system. If the code continues, the fuel system may need to be converted to an in-tank fuel pump and/or regulated (return) fuel system.
MAP SELECT	ECU compares the MAP reading with the Baro reading on key up. If these are different by more than 5kPa, the code is activated.	Double check your MAP selection and make sure that you selected the correct P/N of sensor. It could also mean a problem with the Baro or MAP sensor itself (see above codes).
BARO	The Baro sensor voltage is out of range, and the ECU has defaulted to the last known good Baro value.	Turn the ignition off. Wait 10 seconds, and turn the ignition back on. If the code remains, call customer service. Unless the vehicle has been through a large change in altitude since the last ignition on/off cycle (towed somewhere), everything will function normally.

CLEAR FLOOD

If a flood condition occurs, turn the key on then press the accelerator to wide-open throttle. This tells the ECU to turn off the injectors. Crank the engine to clear the flood condition until the engine starts (release the throttle).

Note: The TPS is self calibrating so the key must be in the ON position prior to pressing the accelerator.

INSTRUCTIONS FOR UPDATING THE ATOMIC EFI

In order to update the Atomic EFI you will first need to download the updated files from AtomicEFI.com. (Right click and choose "Save Target As" if it doesnt download automatically)

UPDATED: 05-31-13 Version numbers below.

ALL THREE UPDATES MUST BE DONE SIMULTANEOUSLY



1. The update will reset all settings in the Atomic EFI.
 - a. Be sure that you make note of all settings in the Initial and Advanced Set-ups prior to performing the update.
2. Download the update files from AtomicEFI.com
 - a. Be sure they are saved in a place that you will find them (the desktop is often the best place to save them).
 - b. DO NOT rename the files, the Atomic EFI will only recognize files with the names assigned by MSD.
3. Transfer the files to the Micro-SD Card that came with the Atomic.

You will need an SD Card reader for this – if you do already not have a reader, they can be found at most electronics stores for less than \$10.

- a. Open the Micro-SD card’s window on your computer.
- b. Drag and drop the MSD files into the folder.
- c. The files must remain in the main folder do NOT put them in a sub-folder.
4. Move the Micro-SD card to the Atomic EFI’s Handheld
5. Ensure the Handheld is plugged in to the Power Module
6. Turn the vehicle’s ignition switch to Key-On
 - a. Do not start the engine
7. At this time the Atomic will automatically update the Handheld.
 - a. This process will take approximately 30 seconds, do not remove power.
8. When the handheld update is complete you will be prompted to update the Atomic ECU as well.
 - a. Use the Handheld joystick see “YES” by pushing the joystick up.
 - b. Push the joystick in to accept.
9. At this time the Atomic ECU will be updated.
 - a. This process will take approximately 30 seconds.
 - b. The beginning of this process will display “Erasing” – this is normal, do not remove power.
 - c. The handheld’s screen will notify you when the update is complete.
10. Use the handheld’s joystick to go back (left) to the main menu.
11. Input all previous settings for the Initial and Advanced setups.
12. Enjoy your updated Atomic EFI.

You can check to see that the Atomic update is successful by looking at the version numbers on the Handheld. To do so go to:

- Display setup
- Firmware versions
- Dash – 2.0.3
- EFI – 1.1.1
- PM. – 1.0.7

TECH NOTES

Service

In case of malfunction, this MSD component will be repaired free of charge according to the terms of the warranty. When returning MSD components for warranty service, **Proof of Purchase** must be supplied for verification. After the warranty period has expired, repair service is based on a minimum and maximum fee.

All returns must have a Return Material Authorization (RMA) number issued to them before being returned. To obtain an RMA number please contact MSD Customer Service at 1 (888) MSD-7859 or visit our website at www.msdpower.com/rma to automatically obtain a number and shipping information.

When returning the unit for repair, leave all wires at the length in which you have them installed. Be sure to include a detailed account of any problems experienced, and what components and accessories are installed on the vehicle. The repaired unit will be returned as soon as possible using Ground shipping methods (ground shipping is covered by warranty). For more information, call MSD at (915) 855-7123. MSD technicians are available from 7:00 a.m. to 5:00 p.m. Monday - Friday (mountain time).

Limited Warranty

MSD warrants this product to be free from defects in material and workmanship under its intended normal use*, when properly installed and purchased from an authorized MSD dealer, for a period of one year from the date of the original purchase. This warranty is void for any products purchased through auction websites. If found to be defective as mentioned above, it will be repaired or replaced at the option of MSD. Any item that is covered under this warranty will be returned free of charge using Ground shipping methods.

This shall constitute the sole remedy of the purchaser and the sole liability of MSD. To the extent permitted by law, the foregoing is exclusive and in lieu of all other warranties or representation whether expressed or implied, including any implied warranty of merchantability or fitness. In no event shall MSD or its suppliers be liable for special or consequential damages.

*Intended normal use means that this item is being used as was originally intended and for the original application as sold by MSD. Any modifications to this item or if it is used on an application other than what MSD markets the product, the warranty will be void. It is the sole responsibility of the customer to determine that this item will work for the application they are intending. MSD will accept no liability for custom applications.