

MSD IGNITION INSTALLATION INSTRUCTIONS

Universal Wire Set for GM GEN III Engines PN 32079 / PN 32073

Parts Included In This Kit:

8 - Spark Plug Wires with 90° and Multi-Angle Boots
9 - LS1 Boots and Terminals
1 - Mini-Stripper-Crimper

Tools Required:

Razor Blade
Vise (4" Minimum)
Needlenose Pliers

Optional:

PN 35051 Pro Crimp Tool

This Universal Wire set gives you the choice of using a 90° or straight/Multi-Angle boot and terminal on the spark plug to accommodate for the header variances. Once you have determined the style boots to use, you can cut the new wires to length then install the correct supplied coil terminal and boot. A Mini-Stripper-Crimper Tool is supplied to help you achieve a strong, factory type crimp.

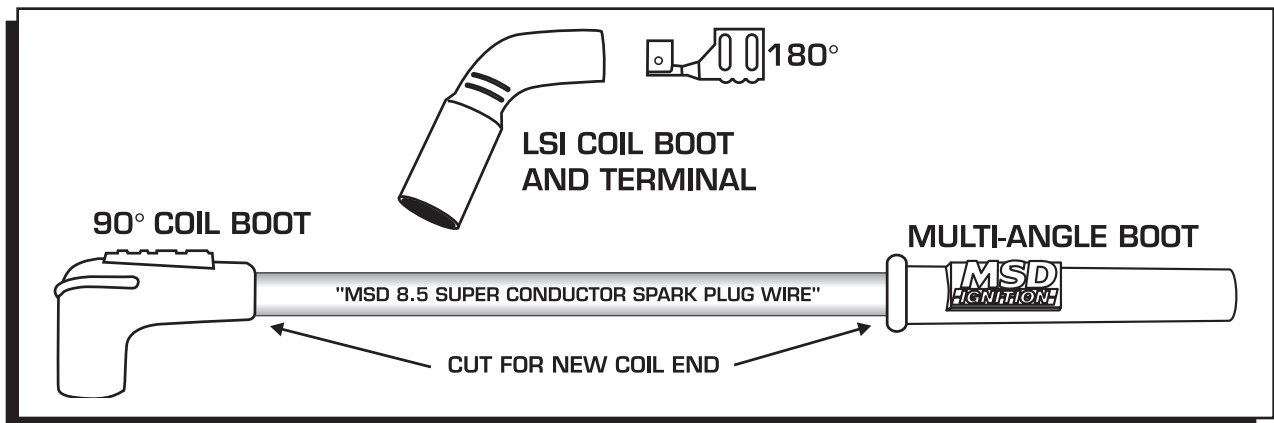

Figure 1 Choosing the Spark Plug Boots and Terminals.

1. Once you've determined wire length and spark plug boot to use, position the wire in the corresponding strip guide of the strip tool.
2. There are two stripping positions on the stripping slot, when installing the LS1 terminal it will require you to strip the wire at standard terminal length (Figure 2).
3. Remove the wire and twist the cut sleeve off in a counterclockwise direction.

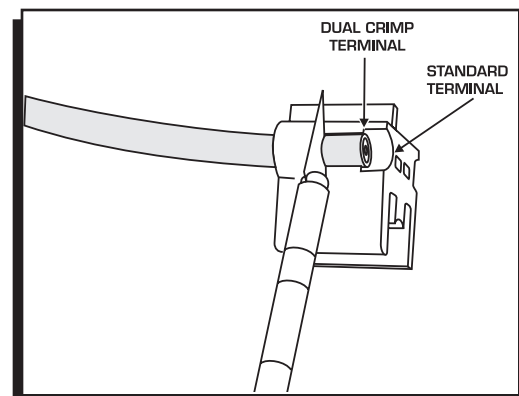

Figure 2 Stripping the Sleeve.

4. To achieve the strongest crimp possible, it is required to bend the crimp tabs over about 90° using needle nose pliers. Figure 3 shows an example.

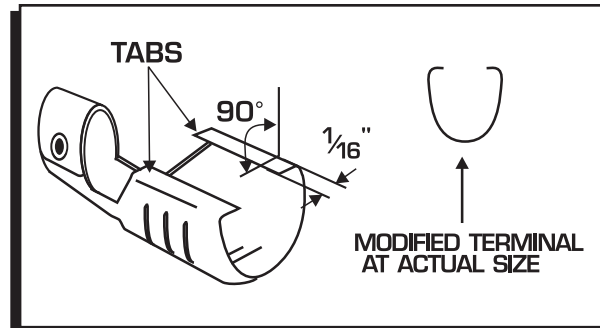

Figure 3 Stripping the Sleeve.

5. Bend the conductor back along the wire insulation. Slide the wire into the terminal with the conductor positioned so it is in contact with the bottom of the terminal (Figure 4). Push the wire through until the sleeve protrudes about 1/8" beyond the crimp tabs.

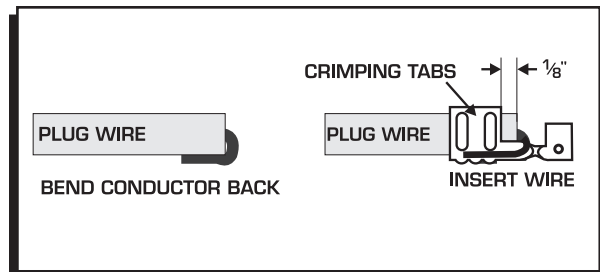

Figure 4 Preparing the Terminals.

6. Position the wire and terminal into the "W" groove side of the Mini-Stripper-Crimper. Align the crimp tabs so they are exactly centered on the tip of the crimp die (Figure 5).
7. Slide the other part of the Mini-Stripper-Crimper over the wire terminal and lightly press them together.
8. Put the assembly into a vise making sure the alignment tabs are on the outside edge of the vise jaws (Figure 6).

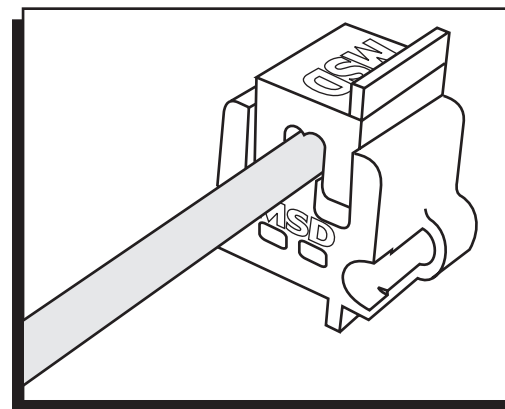

Figure 5 Aligning the Terminal in the Tool.

9. Slowly close the vise making sure the tool and terminal stay properly positioned and aligned (Figure 6). Stop applying pressure when the terminal ends have wrapped securely around the sleeve and grip the wire.

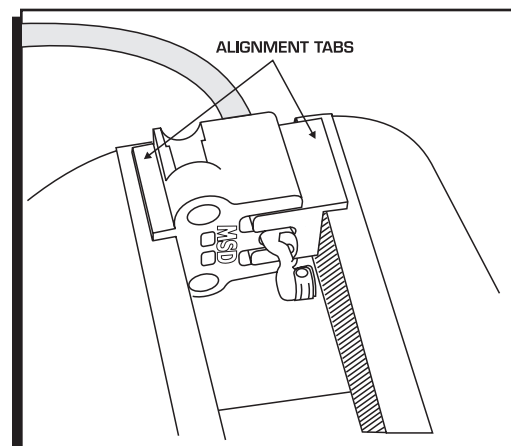

Figure 6 Aligning the Terminal in the Tool.

Note: DO NOT OVER-CRIMP! It is possible to tear the sleeve of the wire by excessive pressure on the vise. This will cause a weaker crimp.

10. Back off the vise and remove the wire from the Crimper. Gently tug the terminal and inspect the position of the conductor to make sure the crimp is solid and firm.
11. To ease installation of the boots, use a drop of a dielectric grease such as MSD's Spark Guard, PN 8804. A can of spray silicone will also work well. Proceed with inserting the wire into the boot (Figure 7).

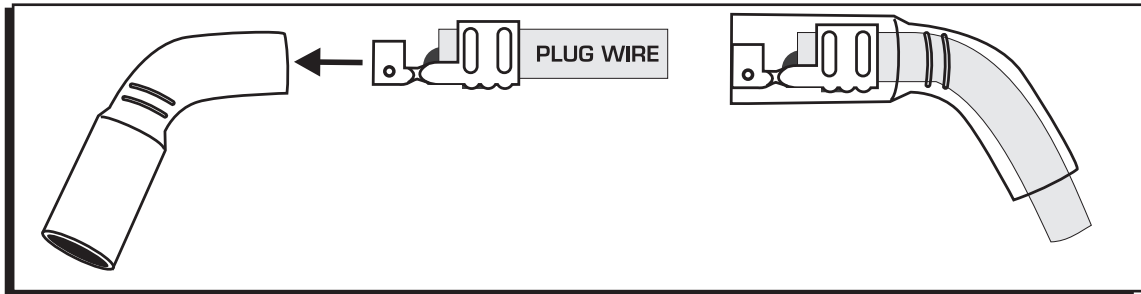

Figure 7 Boot & Installation and Terminal Depth.

NOTES



INSTALLATION INSTRUCTIONS

TECH NOTES

Service

In case of malfunction, this MSD component will be repaired free of charge according to the terms of the warranty. When returning MSD components for warranty service, **Proof of Purchase** must be supplied for verification. After the warranty period has expired, repair service is based on a minimum and maximum fee.

All returns must have a Return Material Authorization (RMA) number issued to them before being returned. To obtain an RMA number please contact MSD Customer Service at 1 (888) MSD-7859 or visit our website at www.msdisignition.com/rma to automatically obtain a number and shipping information.

When returning the unit for repair, leave all wires at the length in which you have them installed. Be sure to include a detailed account of any problems experienced, and what components and accessories are installed on the vehicle. The repaired unit will be returned as soon as possible using Ground shipping methods (ground shipping is covered by warranty). For more information, call MSD Ignition at (915) 855-7123. MSD technicians are available from 7:00 a.m. to 6:00 p.m. Monday - Friday (mountain time).

Limited Warranty

MSD IGNITION warrants this product to be free from defects in material and workmanship under its intended normal use*, when properly installed and purchased from an authorized MSD dealer, for a period of one year from the date of the original purchase. This warranty is void for any products purchased through auction websites. If found to be defective as mentioned above, it will be repaired or replaced at the option of MSD Ignition. Any item that is covered under this warranty will be returned free of charge using Ground shipping methods.

This shall constitute the sole remedy of the purchaser and the sole liability of MSD Ignition. To the extent permitted by law, the foregoing is exclusive and in lieu of all other warranties or representation whether expressed or implied, including any implied warranty of merchantability or fitness. In no event shall MSD Ignition or its suppliers be liable for special or consequential damages.

*Intended normal use means that this item is being used as was originally intended and for the original application as sold by MSD Ignition. Any modifications to this item or if it is used on an application other than what MSD Ignition markets the product, the warranty will be void. It is the sole responsibility of the customer to determine that this item will work for the application they are intending. MSD Ignition will accept no liability for custom applications.