



INSTALLATION INSTRUCTIONS

Street Fire GM HEI Coil PN 5525

Parts Included:

- 1 - Coil, PN 5525
- 1 - 4" Black Ground Wire

INSTALLATION

1. Install the new rotor bushing and rubber isolator. The spring of the rotor bushing must face up (Figure 2).
2. Install the Street Fire Coil. The terminals should slide easily into position into the cap. The Yellow and Red leads go in the outer slots of the cap (Figure 1).
3. Insert the Black ground wire in the center slot of the cap and connect it to one of the Coil's retaining screws (Figure 1).
4. Install the other three retaining screws followed by the coil cover and connect the harnesses.

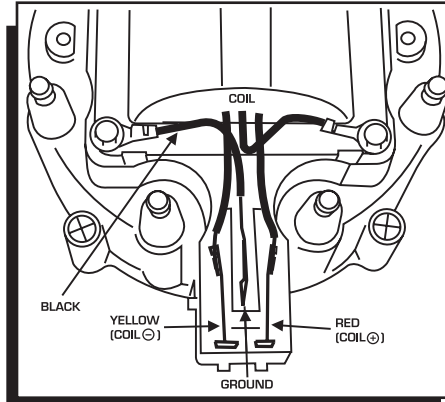

Figure 1 Wire Location.

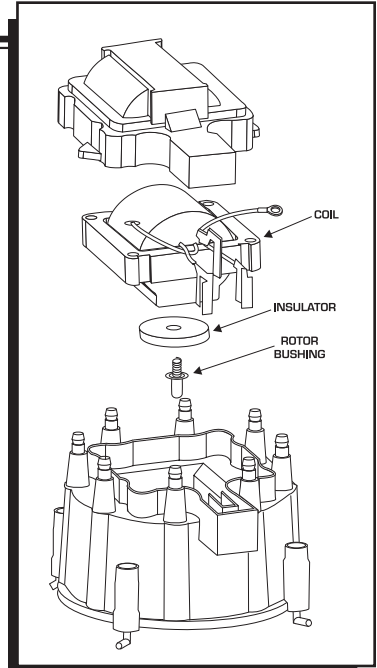

Figure 2 Installing the Street Fire GM HEI Coil.

STREET FIRE • WWW.STREET-FIRE.COM • (915) 857-5200 • FAX (915) 857-3344



INSTALLATION INSTRUCTIONS

Street Fire GM HEI Coil PN 5525

Parts Included:

- 1 - Coil, PN 5525
- 1 - 4" Black Ground Wire

INSTALLATION

1. Install the new rotor bushing and rubber isolator. The spring of the rotor bushing must face up (Figure 2).
2. Install the Street Fire Coil. The terminals should slide easily into position into the cap. The Yellow and Red leads go in the outer slots of the cap (Figure 1).
3. Insert the Black ground wire in the center slot of the cap and connect it to one of the Coil's retaining screws (Figure 1).
4. Install the other three retaining screws followed by the coil cover and connect the harnesses.

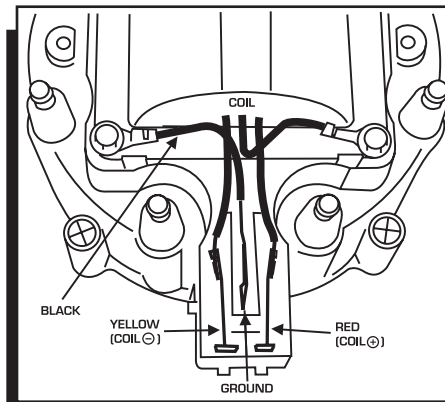

Figure 1 Wire Location.

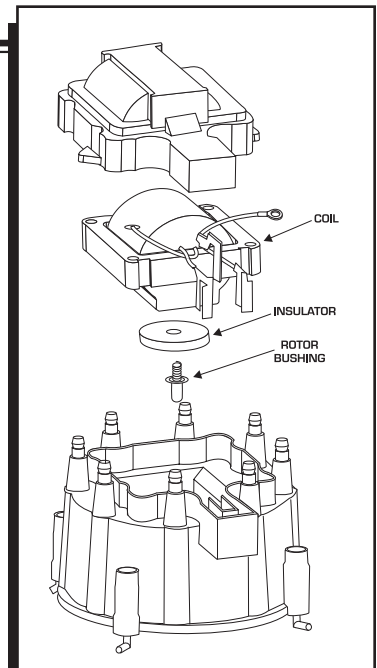

Figure 2 Installing the Street Fire GM HEI Coil.

STREET FIRE • WWW.STREET-FIRE.COM • (915) 857-5200 • FAX (915) 857-3344



INSTALLATION INSTRUCTIONS

Service

In case of malfunction, this MSD component will be repaired free of charge according to the terms of the warranty. When returning MSD components for warranty service, **Proof of Purchase** must be supplied for verification. After the warranty period has expired, repair service is based on a minimum and maximum fee.

All returns must have a Return Material Authorization (RMA) number issued to them before being returned. To obtain an RMA number please contact MSD Customer Service at 1 (888) MSD-7859 or visit our website at www.msdisignition.com/rma to automatically obtain a number and shipping information.

When returning the unit for repair, leave all wires at the length in which you have them installed. Be sure to include a detailed account of any problems experienced, and what components and accessories are installed on the vehicle. The repaired unit will be returned as soon as possible using Ground shipping methods (ground shipping is covered by warranty). For more information, call MSD Ignition at (915) 855-7123. MSD technicians are available from 7:00 a.m. to 5:00 p.m. Monday - Friday (mountain time).

Limited Warranty

MSD IGNITION warrants this product to be free from defects in material and workmanship under its intended normal use*, when properly installed and purchased from an authorized MSD dealer, for a period of one year from the date of the original purchase. This warranty is void for any products purchased through auction websites. If found to be defective as mentioned above, it will be repaired or replaced at the option of MSD Ignition. Any item that is covered under this warranty will be returned free of charge using Ground shipping methods.

This shall constitute the sole remedy of the purchaser and the sole liability of MSD Ignition. To the extent permitted by law, the foregoing is exclusive and in lieu of all other warranties or representation whether expressed or implied, including any implied warranty of merchantability or fitness. In no event shall MSD Ignition or its suppliers be liable for special or consequential damages.

*Intended normal use means that this item is being used as was originally intended and for the original application as sold by MSD Ignition. Any modifications to this item or if it is used on an application other than what MSD Ignition markets the product, the warranty will be void. It is the sole responsibility of the customer to determine that this item will work for the application they are intending. MSD Ignition will accept no liability for custom applications.

STREET FIRE • WWW.STREET-FIRE.COM • (915) 857-5200 • FAX (915) 857-3344

© 2009 Autotronic Controls Corporation

FRM29489

Created 02/09

Printed in U.S.A.



INSTALLATION INSTRUCTIONS

Service

In case of malfunction, this MSD component will be repaired free of charge according to the terms of the warranty. When returning MSD components for warranty service, **Proof of Purchase** must be supplied for verification. After the warranty period has expired, repair service is based on a minimum and maximum fee.

All returns must have a Return Material Authorization (RMA) number issued to them before being returned. To obtain an RMA number please contact MSD Customer Service at 1 (888) MSD-7859 or visit our website at www.msdisignition.com/rma to automatically obtain a number and shipping information.

When returning the unit for repair, leave all wires at the length in which you have them installed. Be sure to include a detailed account of any problems experienced, and what components and accessories are installed on the vehicle. The repaired unit will be returned as soon as possible using Ground shipping methods (ground shipping is covered by warranty). For more information, call MSD Ignition at (915) 855-7123. MSD technicians are available from 7:00 a.m. to 5:00 p.m. Monday - Friday (mountain time).

Limited Warranty

MSD IGNITION warrants this product to be free from defects in material and workmanship under its intended normal use*, when properly installed and purchased from an authorized MSD dealer, for a period of one year from the date of the original purchase. This warranty is void for any products purchased through auction websites. If found to be defective as mentioned above, it will be repaired or replaced at the option of MSD Ignition. Any item that is covered under this warranty will be returned free of charge using Ground shipping methods.

This shall constitute the sole remedy of the purchaser and the sole liability of MSD Ignition. To the extent permitted by law, the foregoing is exclusive and in lieu of all other warranties or representation whether expressed or implied, including any implied warranty of merchantability or fitness. In no event shall MSD Ignition or its suppliers be liable for special or consequential damages.

*Intended normal use means that this item is being used as was originally intended and for the original application as sold by MSD Ignition. Any modifications to this item or if it is used on an application other than what MSD Ignition markets the product, the warranty will be void. It is the sole responsibility of the customer to determine that this item will work for the application they are intending. MSD Ignition will accept no liability for custom applications.

STREET FIRE • WWW.STREET-FIRE.COM • (915) 857-5200 • FAX (915) 857-3344

© 2009 Autotronic Controls Corporation

FRM29489

Created 02/09

Printed in U.S.A.