

# MSD INSTALLATION INSTRUCTIONS

## E-Spark™ Ignition Module PN 6100M

### INSTALLATION AND ELECTRICAL WIRING PROCEDURE

Apply a liberal coat of heat sink compound to the bottom of the module before mounting the module to its plate in the distributor. Slide the three wires from the MODULE, through the grommet, to outside the distributor housing. Put the three wires from the MODULE in the TERMINAL PIN HOUSING: GREEN WIRE in hole #1, BROWN WIRE in hole #2, RED WIRE in hole #3. Plug the three wire harness (PN 29349, not supplied with this kit) into the TERMINAL PIN HOUSING.

**CAUTION:** Make sure that the vehicle is originally equipped from the factory with an ignition ballast resistor or loom resistance wire from the ignition switch to the coil (+) terminal. If the vehicle is not originally equipped from the factory with an ignition ballast resistor or loom resistance wire, a Mallory ballast resistor, PN 700, must be installed in series on the wire from the ignition switch to the coil (+) terminal. See a service manual for the vehicle for further information. For example, vehicles equipped with Ford TFI, or Delco HEI ignition require the installation of a Mallory ballast resistor, PN 700. Failure to use a resistor will result in the eventual destruction of the module.

For optimum performance in systems without a HyFire or similar ignition control, use one of Mallory's 3 specially matched coils eliminates the need for a ballast resistor or a resistance wire. These coils are: 29219- Chrome Canister Coil, 30450 PROMASTER e Coil and 29450 PROMASTER Classic Coil.

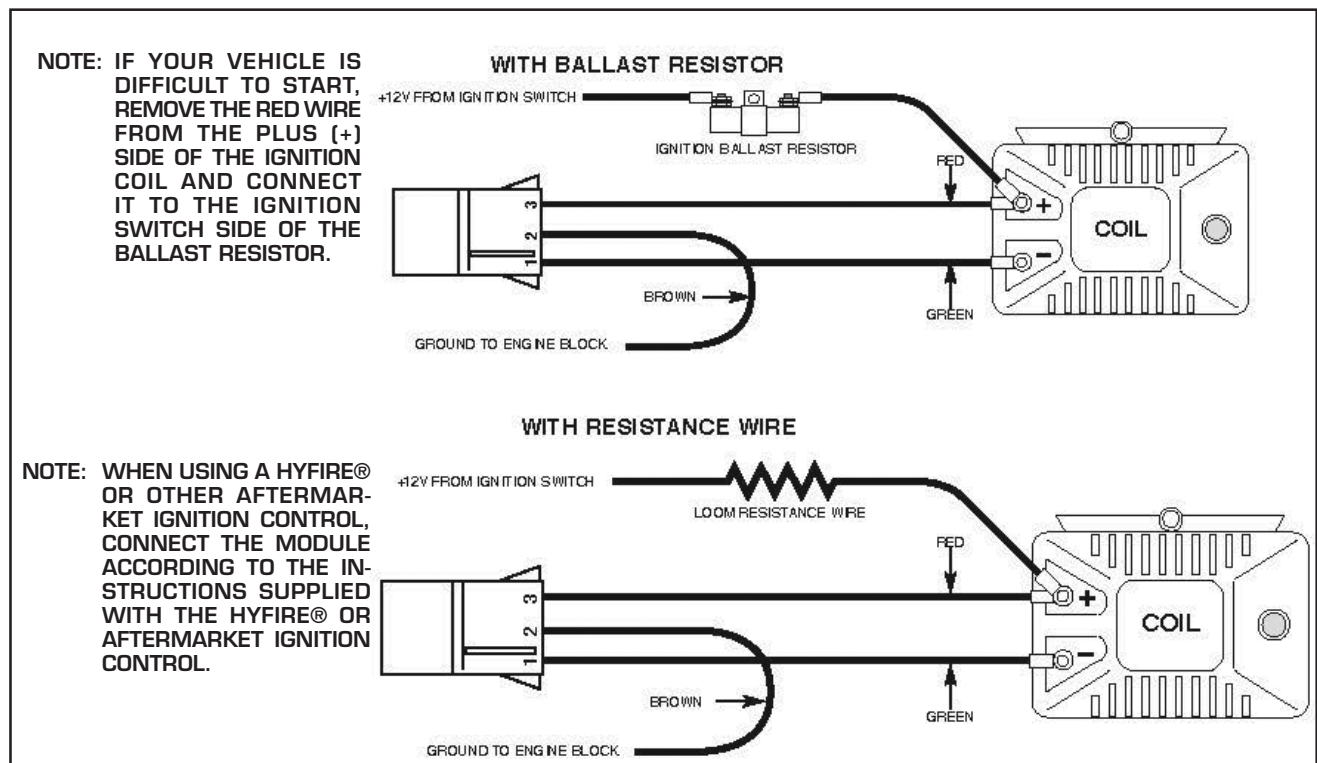



# INSTALLATION INSTRUCTIONS

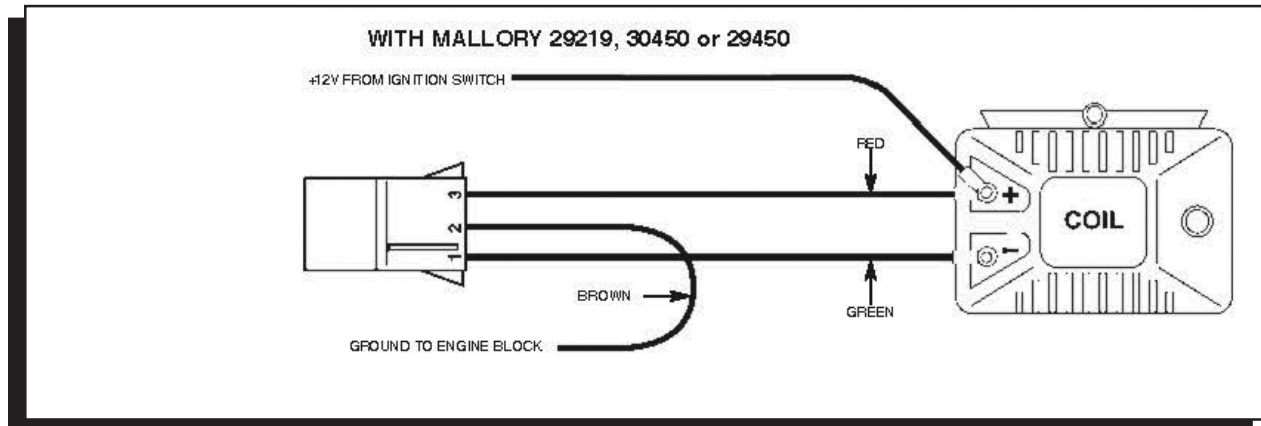

## Service

In case of malfunction, this MSD component will be repaired free of charge according to the terms of the warranty. When returning MSD components for warranty service, **Proof of Purchase** must be supplied for verification. After the warranty period has expired, repair service is based on a minimum and maximum fee.

**All returns must have a Return Material Authorization (RMA) number** issued to them before being returned. To obtain an RMA number please contact MSD Customer Service at 1 (888) MSD-7859 or visit our website at [www.msdpower.com/rma](http://www.msdpower.com/rma) to automatically obtain a number and shipping information.

When returning the unit for repair, leave all wires at the length in which you have them installed. Be sure to include a detailed account of any problems experienced, and what components and accessories are installed on the vehicle. The repaired unit will be returned as soon as possible using Ground shipping methods (ground shipping is covered by warranty). For more information, call MSD at (915) 855-7123. MSD technicians are available from 7:00 a.m. to 5:00 p.m. Monday - Friday (mountain time).

## Limited Warranty

MSD warrants this product to be free from defects in material and workmanship under its intended normal use\*, when properly installed and purchased from an authorized MSD dealer, for a period of one year from the date of the original purchase. This warranty is void for any products purchased through auction websites. If found to be defective as mentioned above, it will be repaired or replaced at the option of MSD. Any item that is covered under this warranty will be returned free of charge using Ground shipping methods.

This shall constitute the sole remedy of the purchaser and the sole liability of MSD. To the extent permitted by law, the foregoing is exclusive and in lieu of all other warranties or representation whether expressed or implied, including any implied warranty of merchantability or fitness. In no event shall MSD or its suppliers be liable for special or consequential damages.

\*Intended normal use means that this item is being used as was originally intended and for the original application as sold by MSD. Any modifications to this item or if it is used on an application other than what MSD markets the product, the warranty will be void. It is the sole responsibility of the customer to determine that this item will work for the application they are intending. MSD will accept no liability for custom applications.