

MSD[®] IGNITION SUPPLEMENT

MSD 6ALN, PN 6430 AND 6TN, PN 6401 IGNITION CONTROLS

IMPORTANT: Read instructions thoroughly before attempting installation.

The 6ALN and 6TN are Ignition Controls designed for NASCAR use. The 6-Pin Weathertight connectors supplied with the ignitions are NASCAR approved connectors and will directly connect to many common wiring harnesses.

The circuit boards of both ignitions are encased in a clear compound for extra resistance to vibration.

Parts Included

- 1 - Ignition Control
- 1 - 6-Pin Weathertight Wiring Harness
- 1 - 1-Pin Weathertight Wiring Harness
- 4 - Vibration Mounts
- 4 - RPM Modules (6ALN only): 3,000, 6,000, 7,000, 8,000

MOUNTING

The Ignitions can be mounted in any position. They may be mounted in the engine compartment however they should be kept clear of direct engine heat sources. Use the Ignition as a template to mark the location of the mounting holes. Using an 1/8" drill bit, remove the ignition and drill the holes. Install the vibration mounts and the ignition.

WIRING

Figure 1 shows the position, color and function of each wire. Figure 2 shows a general installtion.

Triggering

The MSD can be triggered by points or with a magnetic pickup.

Points: The single White wire of the MSD is for points triggering. It connects to the points output wire of the distributor.

Magnetic Pickup: The Magnetic Pickup Wires are in the 6-Pin connector. The Mag positive (+) wire is Violet, the Mag negative (-) is Green. They are in the terminals marked "F" and "E".

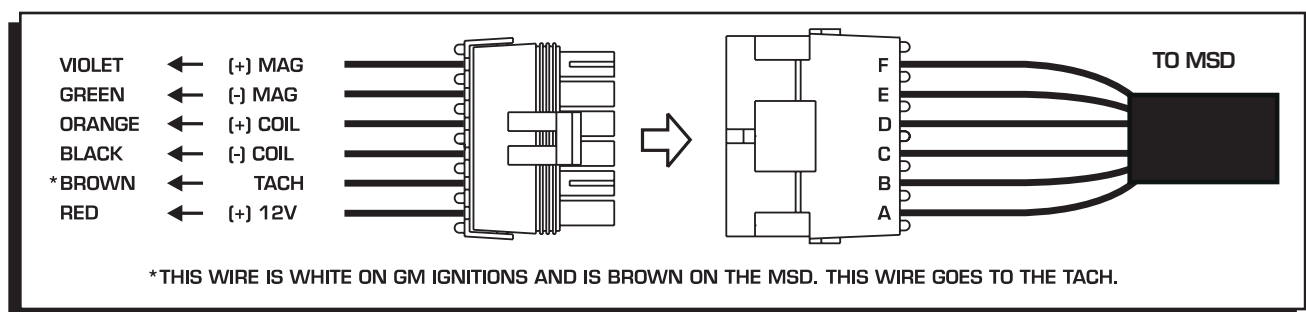

Figure 1 The Color, Function and Position of Each Wire.

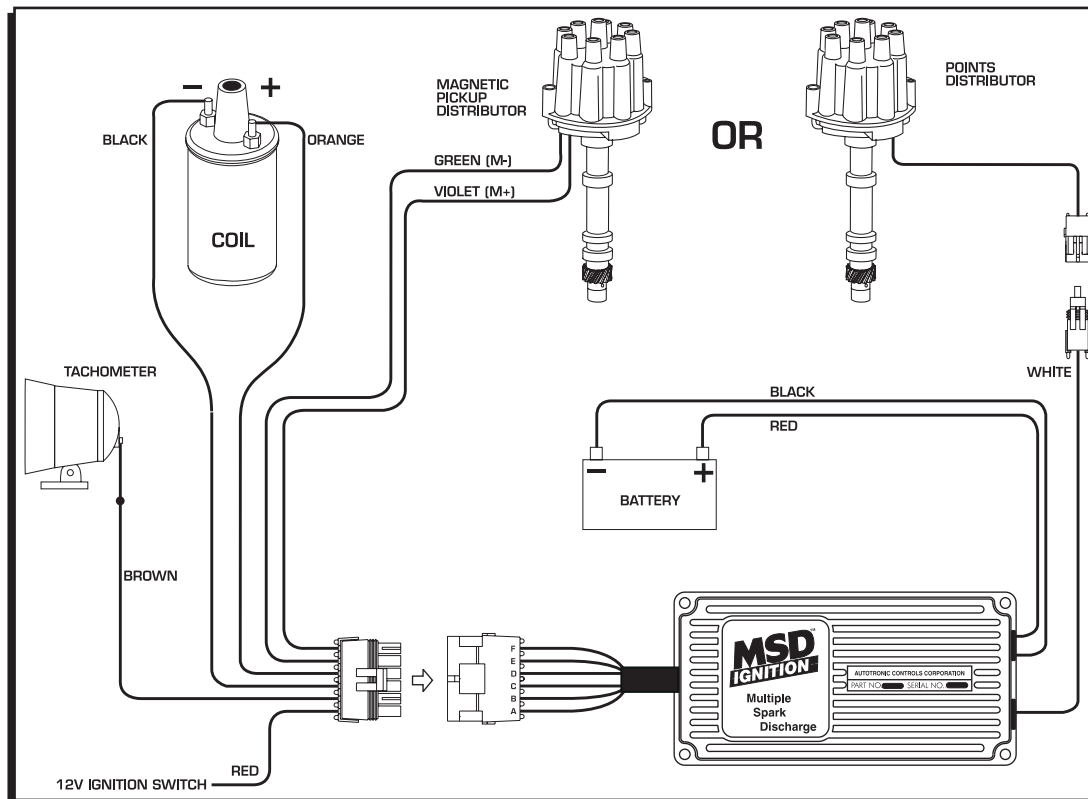

Figure 2 General Installation.

Service

In case of malfunction, this MSD component will be repaired free of charge according to the terms of the warranty. When returning MSD components for service, **Proof of Purchase** must be supplied for warranty verification. After the warranty period has expired, repair service is charged based on a minimum and maximum charge.

All returns must have a Return Material Authorization (RMA) number issued to them before being returned. To obtain an RMA number please contact MSD Customer Service at 1 (888) MSD-7859 or visit our website at www.msdisignition.com/rma to automatically obtain a number and shipping information.

When returning the unit for repair, leave all wires at the length in which you have them installed. Be sure to include a detailed account of any problems experienced, and what components and accessories are installed on the vehicle.

The repaired unit will be returned as soon as possible after receipt. (Ground shipping is covered by warranty). All units are returned regular UPS unless otherwise noted. For more information, call MSD Ignition at (915) 855-7123. MSD technicians are available from 7:00 a.m. to 6:00 p.m. Monday - Friday (mountain time).

Limited Warranty

MSD IGNITION warrants MSD Ignition products to be free from defects in material and workmanship under normal use and if properly installed for a period of one year from date of purchase. If found to be defective as mentioned above, it will be replaced or repaired if returned prepaid along with proof of date of purchase. This shall constitute the sole remedy of the purchaser and the sole liability of MSD Ignition. To the extent permitted by law, the foregoing is exclusive and in lieu of all other warranties or representations whether expressed or implied, including any implied warranty of merchantability or fitness. In no event shall MSD Ignition be liable for special or consequential damages.