

MSD[®] IGNITION INSTALLATION INSTRUCTIONS

MSD Dual Mag HVC Pro-Billet Distributor Toyota - PN 83944, Chevrolet R07 - PN 83945, Chevrolet SB2 - PN 83941, Dodge R6/P8 - PN 83946, Ford FR9 - PN 83947

ONLINE PRODUCT REGISTRATION: Register your MSD product online and you'll be entered in our monthly 8.5mm Super Conductor Spark Plug Wire give-away! Registering your product will help if there is ever a warranty issue with your product and helps the MSD R&D team create new products that you ask for! Go to www.msdisignition.com/registration.

Parts Included:	2 - Retainer Screws	Parts Required:
1 - Distributor	1 - Gasket (Chevy Only)	Distributor Gear (except PN 83941*)
1 - Wire Retainer	2 - O-Rings (Chevy Only)	Connectors
1 - Coil Wire Retainer	1 - O-Ring (Ford/Chrysler/Toyota Only)	

Note: The HVC Pro-Billet Distributor is NOT supplied with a gear. See page 2 for gears.

* Chevrolet SB2 - PN 83941 is supplied with Bronze Gear PN 8471.

IMPORTANT

The MSD HVC Pro-Billet Distributors are the most advanced racing distributors available. Take the time to read these instructions thoroughly before installing the distributor. There are a variety of adjustments that can be made to improve the performance of your engine and should be understood prior to running the engine.

Use of a distributor spin machine (or equivalent), is recommended to take full advantage of the HVC's adjustable features. With a degree wheel and pointer, you will be able to easily and accurately set the timing of the secondary pickup.

WIRING

These Distributors have no connectors. They have two shielded cables.

SHIELDED CABLE	
VIOLET	Connects to Mag +
GREEN	Connects to Mag -
EXPOSED WIRE	Ground connects at Ignition box.



Figure 1 Shielded Cables.

PICKUP ALIGNMENT AND ADJUSTMENTS

The HVC Pro-Billet Distributor features a primary and secondary pickup. These are stacked together with the primary positioned on the bottom. The primary is fixed while the secondary pickup is adjustable +/- 8°. The pickups are aligned at the factory at 0° advance/retard. **The position of the secondary pickup will need to be set to your specifications.**

When installing the distributor there is an alignment indicator (Figure 3). By aligning the reluctor paddle with the indicator, the timing will be within approximately +/- 3° of the desired amount. To adjust the secondary pickup, loosen the two allen head screws on the top pickup. Next, turn the eccentric using an 11/32" wrench to move the pickup (Figure 3). Secure the screws when the desired timing is reached.

SERVICE

MSD designed the HVC Pro-Billet Distributor to be completely serviceable. Replacement parts are listed on the next page.

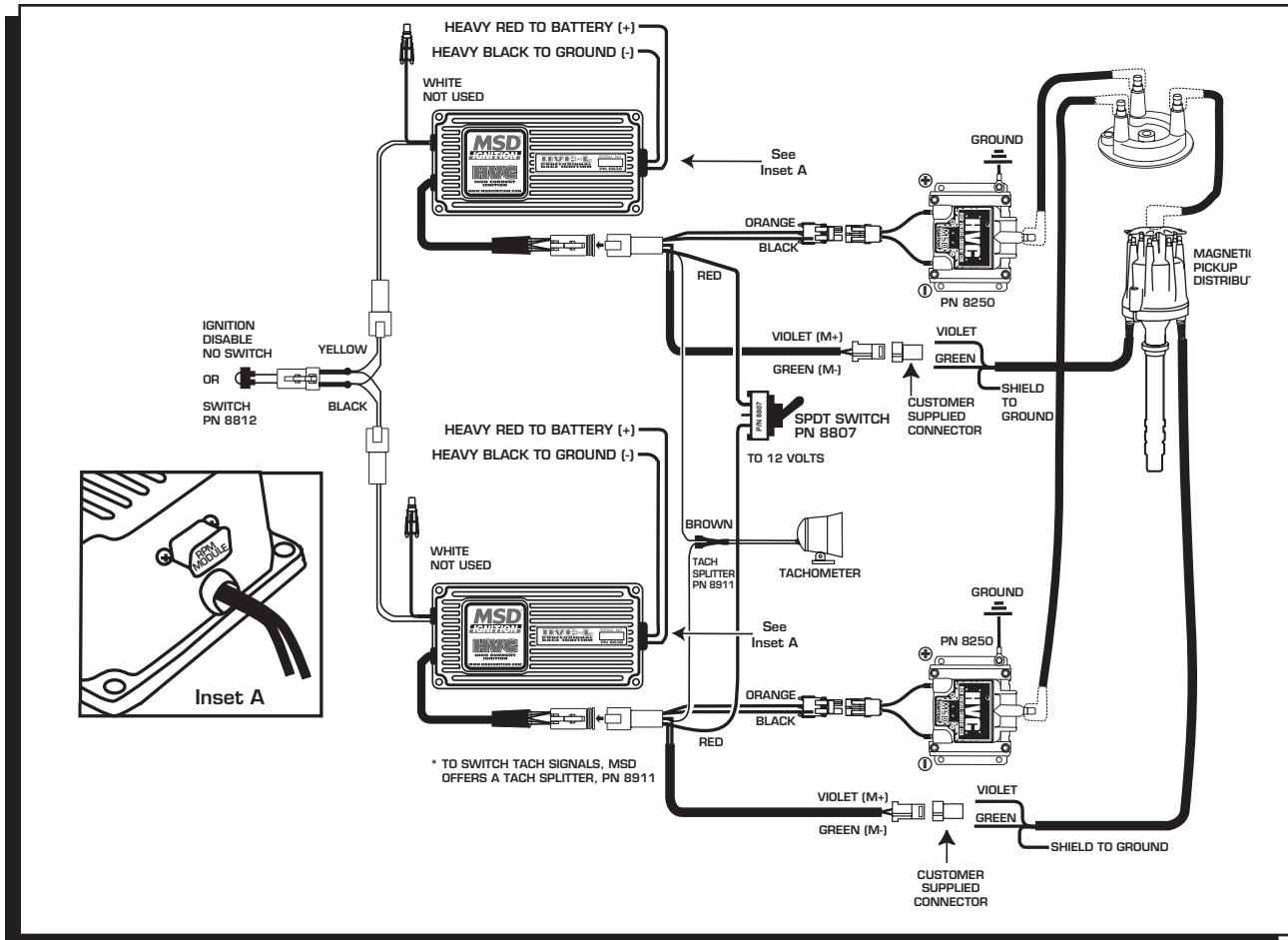

Figure 2 Dual Ignitions and Coils with a Dual Pickup Distributor.

SERVICE PARTS:

Rotor - PN 8484
Reluctor Installation/Removal
Tool - PN 83492

Pickup Assemblies

Upper - PN 84664
Lower - PN 84663

Bronze Gears Chevrolet

Standard - PN 8471
+0.006" - PN 8472

Ford Windsor

Standard - PN 8585

Toyota

N/A: Contact TRD
for information

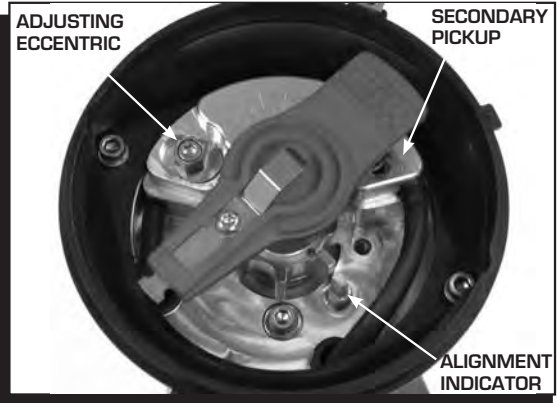

Figure 3 Adjusting the Secondary Pickup.

SERVICE PROCEDURE

LOWER HOUSING

To replace the distributor bearings and seals, the lower housing must be disassembled. Both disassembly and re-assembly require the lower housing to be heated for proper clearance. Review the following procedure before starting the service. Figures 4 and 5 show exploded views of the five distributors available.

1. Remove distributor cap.
2. Remove the reluctor. Use the installation/removal tool PN 83492 to prevent the shaft from turning (Figure 6). Remove the reluctor attaching bolt using a 5/16", 12pt deepwell socket.
3. Remove the two bolts that retain the pickups.
4. Remove the four bolts retaining the upper housing and take it off.
5. Remove the distributor gear and any spacers if so equipped.
6. The upper bearing is an interference fit and needs to be heated to be removed. Place the lower housing and shaft assembly in an oven at 300°F for approximately 30 minutes. When heated, the shaft and bearing assembly should slide out of the aluminum housing. A slight tap on the shaft may be necessary.
7. If distributor is equipped with a lower bearing remove it while the housing is hot. If equipped with a lower bushing, it can be replaced if necessary.
8. Remove and replace the two seals in the housing. The new seals install with their flat sides facing each other. Lubricate the seals with grease (Figure 7).
9. Place the lower housing in an oven at 250° for approximately 30 minutes.
10. While the lower housing is heating, install the new bearing on the shaft (Figure 8).
11. Install the shaft assembly into the lower housing. It is fully seated when the bearing protrudes approximately 0.005" – 0.010" out of the housing (Figure 9). If the clearance is more, the housing may have cooled too much before the bearing was fully installed.
12. Install the gear.
 - a. Chevrolet – Check clearance between gear and housing. It should be greater than 0.015". If under 0.015" the bearing may not be seated correctly (Figure 10).
 - b. Ford – Install gear spacer. Press on gear leaving 0.005" clearance between it and the spacer.

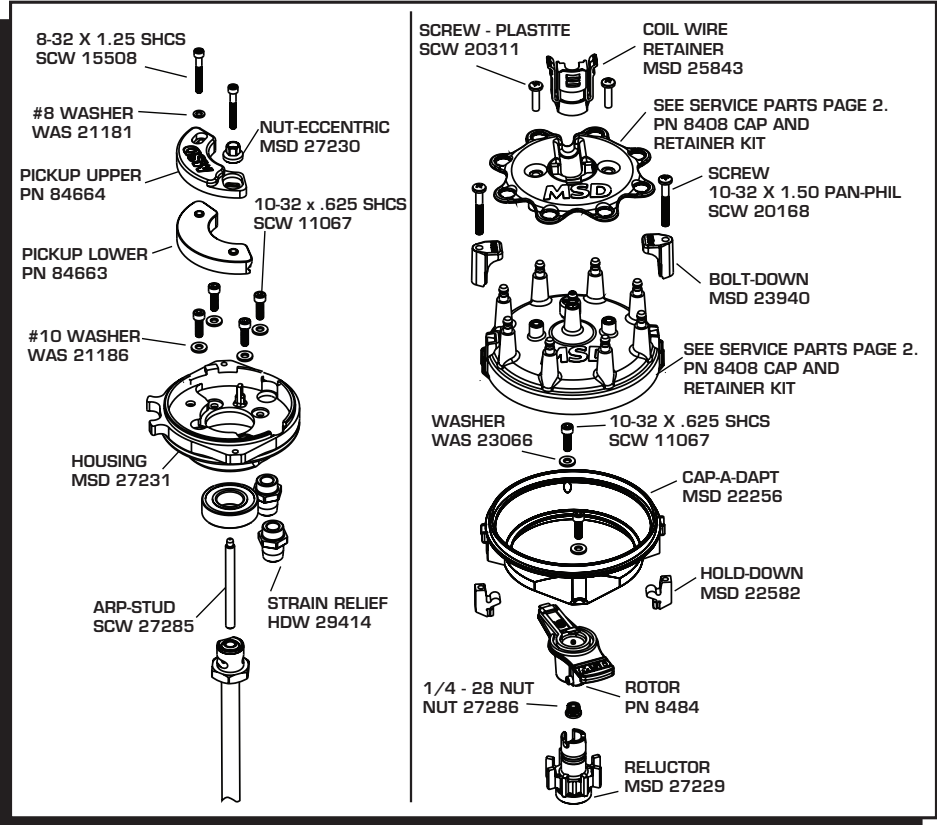

Figure 4 Upper Housing Exploded Views.

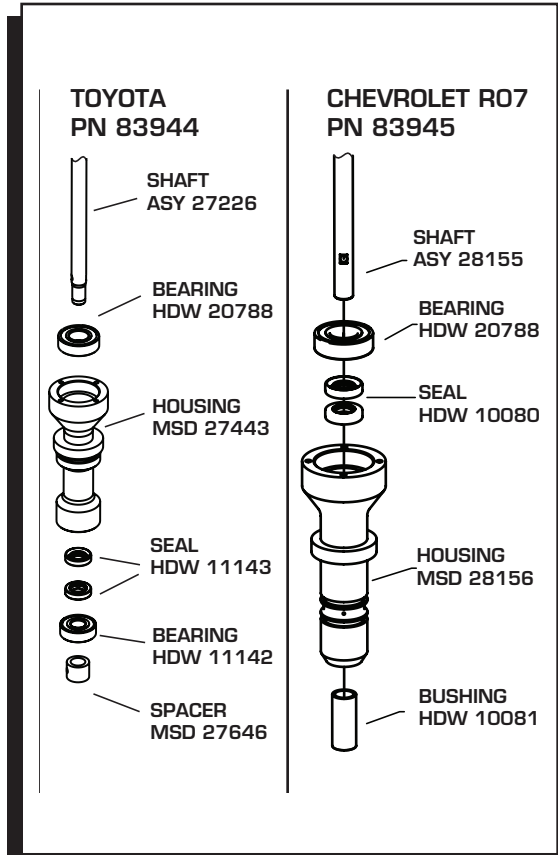
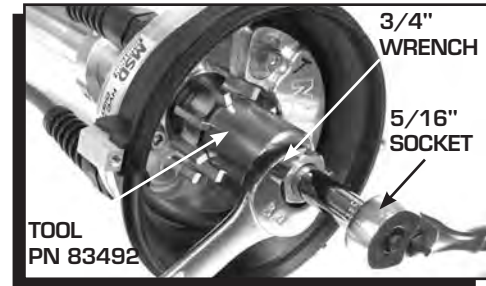
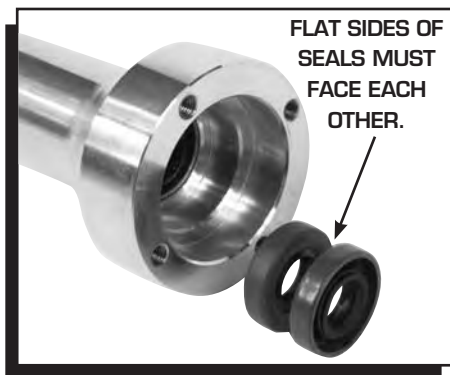
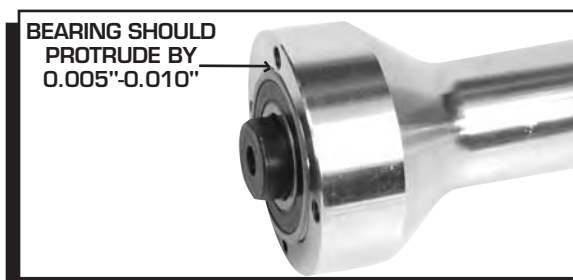
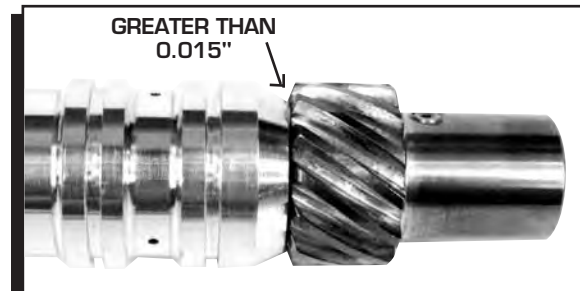

Figure 5 Lower Housing Exploded Views.

- c. Mopar R5 – Install gear spacer and shim. Check clearance between gear and spacer. It should be between 0.005”-0.010”. If under 0.005” the bearing may not be seated correctly.
- d. Toyota – Install gear spacer with roll pin. Press on gear until it stops against the spacer.
13. Assemble the upper housing.
14. Install Pickup screws.
15. Install reluctor using special tool PN 83492. Apply moly lube to the nut and torque to 10 lb-ft. (Figure 6).
16. Adjust pickup phasing and tighten the pickup bolts.

**Figure 6 Removing the Reluctor.****Figure 7 Installing New Seals.****Figure 8 Installing the New Bearing.****Figure 9 Checking Bearing to Housing Clearance.****Figure 10 Checking Gear to Housing Clearance.**

Service

In case of malfunction, this MSD component will be repaired free of charge according to the terms of the warranty. When returning MSD components for warranty service, **Proof of Purchase** must be supplied for verification. After the warranty period has expired, repair service is based on a minimum and maximum fee.

All returns must have a Return Material Authorization (RMA) number issued to them before being returned. To obtain an RMA number please contact MSD Customer Service at 1 (888) MSD-7859 or visit our website at www.msdisignition.com/rma to automatically obtain a number and shipping information.

When returning the unit for repair, leave all wires at the length in which you have them installed. Be sure to include a detailed account of any problems experienced, and what components and accessories are installed on the vehicle. The repaired unit will be returned as soon as possible using Ground shipping methods (ground shipping is covered by warranty). For more information, call MSD Ignition at (915) 855-7123. MSD technicians are available from 7:00 a.m. to 5:00 p.m. Monday - Friday (mountain time).