



INSTALLATION INSTRUCTIONS

MSD Pro-Billet Ready-to-Run Ford Flathead, 1949-1953 PN 8573

ONLINE PRODUCT REGISTRATION: Register your MSD product online and you'll be entered in our monthly 8.5mm Super Conductor Spark Plug Wire give-away! Registering your product will help if there is ever a warranty issue with your product and helps the MSD R&D team create new products that you ask for! Go to www.msdisignition.com/registration.

Important: Read these instructions before attempting the installation.

Parts Included:

1 - Pro-Billet Distributor	1 - Advance Kit
1 - Rotor, PN 8467	1 - 3-Pin Harness
1 - Distributor Cap, PN 8433	1 - Tube of Gear Lubricant
1 - Wire Retainer	1 - Vacuum Advance Lock-Out Kit
2 - 1.5" Self Tapping Screws	1 - Gear Spacing Tool
2 - 10-32 x 3/4" Socket Head Screws	1 - Gear and Hardware
	1 - Gray Tach Jumper

WARNING: Before installing the MSD Ready-to-Run Distributor, disconnect the battery cables. When disconnecting the battery cables, always remove the Negative (-) cable first and install it last.

Note: The terminals of this Ready-to-Run Distributor require spark plug style terminals. You may need to change the terminals and boots of your wires. MSD offers two kits, PN 8849 or PN 8848 that are supplied with nine boots and terminals.

TIMING FUNCTIONS

Before continuing with the installation, here are a few definitions you should be aware of:

Initial Timing: This is the base timing (also referred to as idle timing) of the engine before the centrifugal advance begins.

Centrifugal Advance: The centrifugal (or mechanical) advance mechanism is made up of weights, springs, advance cams, and an advance stop bushing. The amount and rate of advance that your distributor is capable of is determined by the centrifugal timing. If you ever wish to lock out the centrifugal advance, refer to the centrifugal advance section.

Total Timing: This is the total of the initial timing plus the centrifugal advance added together. Example: 10° Initial + 25° centrifugal = 35° Total Timing. (When checking Total timing, disconnect and cap the vacuum canister and plug the vacuum line.)

Vacuum Advance: The vacuum advance will advance the timing up to 10° during partial throttle driving (with 15 lbs of vacuum). The vacuum line should be routed to a ported vacuum outlet above the throttle plates.

Note: MSD Distributors are supplied with the heavy (slow) advance springs and the 21° stop bushing installed. This is to prevent detonation in certain applications. Review the information on pages 2-4 to determine the best advance curve for your application.

RPM LIMIT AND TACHOMETER INFORMATION

Tach Signal: The Ready-to-Run Distributor features a Gray Tach Output wire which provides a clean signal for most tachometers and even some aftermarket fuel injection systems. The signal output is a 12 volt square wave, 20° duty cycle. This wire is also responsible for programming the built-in rev limiter.

Rev Limiter: The Ready-to-Run Distributor has a built-in rev limit that can easily be adjusted from 2,000 rpm to over 10,000 rpm. The default is 10,000 rpm. To set the rev limiter, run the engine to half the desired rpm then ground the Gray Tach wire (a jumper is supplied) for approximately one second. Every time the key is turned to the On position, the tach will display the programmed rpm limit. See page 8 for the programming procedure.

CHOOSING AN ADVANCE CURVE

The function of the advance curve is to match the ignition timing to the burning rate of the fuel and speed (rpm) of the engine. Any factor that changes the burning rate of the fuel or the engine speed can cause a need for an ignition timing change. Figure 1 shows some of the factors that will affect engine timing.

FACTOR	Advance Timing	Retard Timing
	For	For
Cylinder Pressure	Low	High
Vacuum	High	Low
Energy of Ignition	Low	High
Fuel Octane	High	Low
Mixture (Air/Fuel)	Rich	Lean
Temperature	Cool	Hot
Combustion Chamber Shape	Open	Compact
Spark Plug Location	Offset	Center
Combustion Turbulence	Low	High
Load	Light	Heavy

Figure 1 Ignition Timing Factors.

As you can see from the chart, most factors will change throughout the range of the engine operation. The timing mechanism of the distributor must make timing changes based on these factors.

Example: An engine has 11:1 compression, a high energy ignition and turns 5,500 rpm. With the specifications given, you will have to retard the timing for the high compression and high energy ignition. By comparing the engine's specifications against the chart, a usable timing guideline can be found. Engines with a combination of items from both columns will require a timing that is set in the mid range.

Obviously a full technical explanation of correct ignition timing would be very complicated. The best way to arrive at a suitable ignition curve for your engine is to use the Ignition Timing Factors Chart as a guide and compare it to the Advance Graphs in Figure 4 until a suitable curve is found. When selecting your advance curve, use detonation (engine ping) as an indicator of too much advance, and a decrease in power as an indicator of too little advance.

TIPS ON SELECTING AN ADVANCE CURVE

- Use as much initial advance as possible without encountering excessive starter load.
- Start the centrifugal advance just above the idle rpm.
- The starting point of the centrifugal advance curve is controlled by the installed length and tension of the spring.
- How quickly the centrifugal advance (slope) comes in is controlled by the spring stiffness. The stiffer the spring, the slower the advance curve.
- The amount of advance is controlled by the advance bushing. The bigger the bushing, the smaller the amount of advance.

CENTRIFUGAL ADVANCE CURVE

SELECTING THE ADVANCE SPRINGS

The rate, or how quick the advance comes in is determined by the type of springs which are installed on the distributor. The MSD distributors are equipped with two Heavy Silver springs installed. These will give you the slowest advance curve possible (Figure 2). The parts kit contains two additional sets of springs which can be used to match the advance curve to your particular application. Refer to the Spring Combination Chart (Figure 3) for combinations that can be achieved.

To change the springs, remove the cap and rotor and use needlenose pliers to remove the springs. Be sure the new springs seat in the groove on the pin.

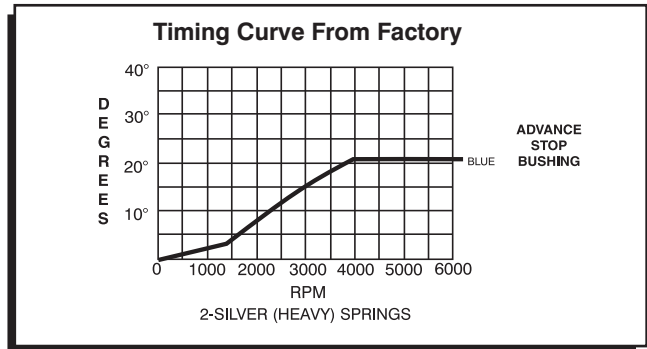

Figure 2 The Factory Equipped Curve.

SPRING COMBINATION	RATE OF ADVANCE	FIGURE 4
2- Heavy Silver	SLOWEST	A
1- Heavy Silver 1- Light Blue		B
1-Heavy Silver 1-Light Silver		C
2- Light Blue		D
1- Light Silver 1- Light Blue		E
2- Light Silver		F
		FASTEST

Figure 3 Spring Combination Chart.

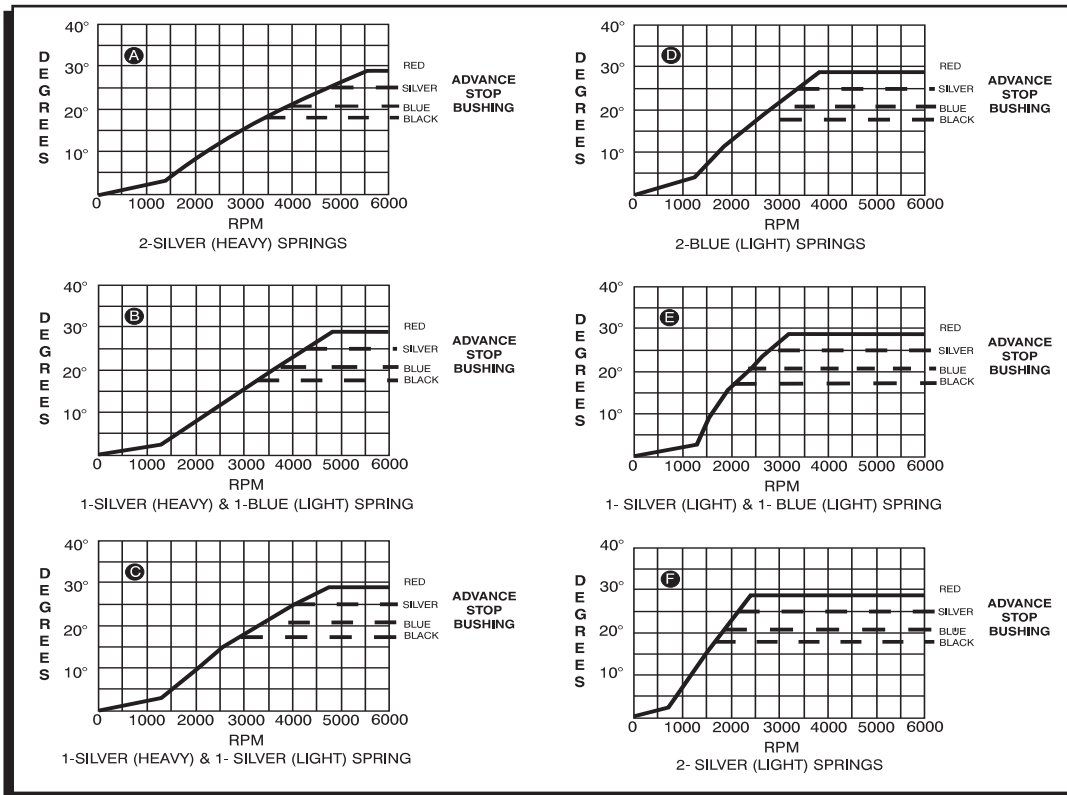

Figure 4 Advance Curves.

SELECTING THE ADVANCE STOP BUSHING

Three different advance stop bushings are supplied in the distributor kit. The distributor comes with a Blue (21°) bushing already installed. If a different amount of centrifugal advance is desired, follow the next procedure to change the bushings. The chart in Figure 5 gives the size and approximate degrees for the corresponding bushings.

CHANGING THE ADVANCE STOP BUSHINGS

1. Remove the distributor cap and rotor.
2. Remove the locknut and washer on the bottom of the advance assembly (Figure 6).
3. Remove the bushing and install the new one. Install the washer and locknut.

LOCKING OUT THE CENTRIFUGAL ADVANCE

1. Remove the advance springs, weights and the advance stop bushing from the advance assembly.
2. Remove the roll-pin from the drive gear and remove the gear from the shaft.
3. Slide the shaft two inches out of the housing.
4. Rotate the shaft 180° and insert the advance stop bushing pin into the small hole on the advance plate (Figure 7).
5. Install the locknut and washer to the advance stop bushing pin.
6. Install the drive gear and roll-pin.

Note: If you want to lock out the vacuum advance, see page 7.

BUSHING SIZE	APPROXIMATE CRANKSHAFT DEGREES
Red-Smallest	28
Silver	25
Blue	21
Black-Largest	18

Figure 5 Advance Stop Bushing Chart.

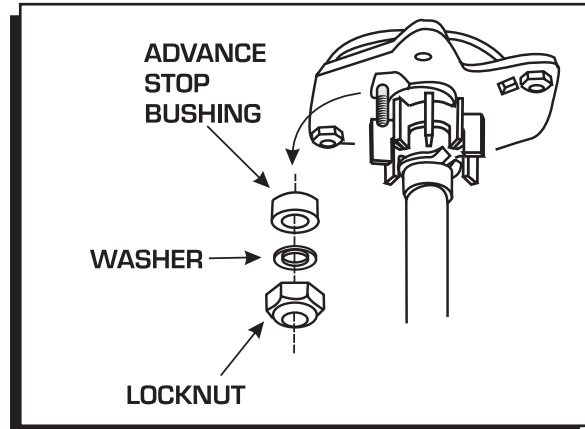

Figure 6 Changing the Advance Stop Bushing.

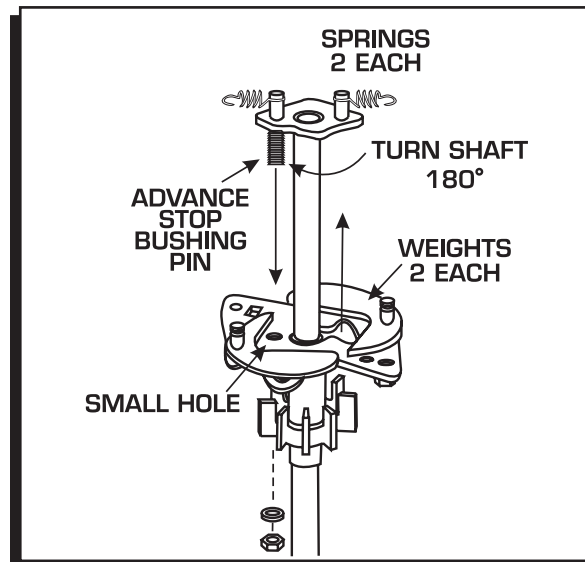

Figure 7 Locking Out the Advance.

REMOVING THE DISTRIBUTOR

1. Remove the existing distributor cap without disconnecting any of the spark plug wires.
2. With the cap off, crank the engine until the rotor is aimed at a fixed point on the engine or firewall. Note this position by making a mark (Figure 8).
3. Place the distributor cap back on and note which plug wire the rotor is pointing to. MARK THE SPARK PLUG WIRES and remove the distributor cap.
4. Disconnect the wiring from the distributor.
5. Loosen the distributor hold down clamp and slide the clamp out of the way.
6. Lift the distributor out of the engine. Note that the rotor rotates as you lift the distributor out. This is due to the helical cut gear and should be taken into consideration when installing the new distributor.

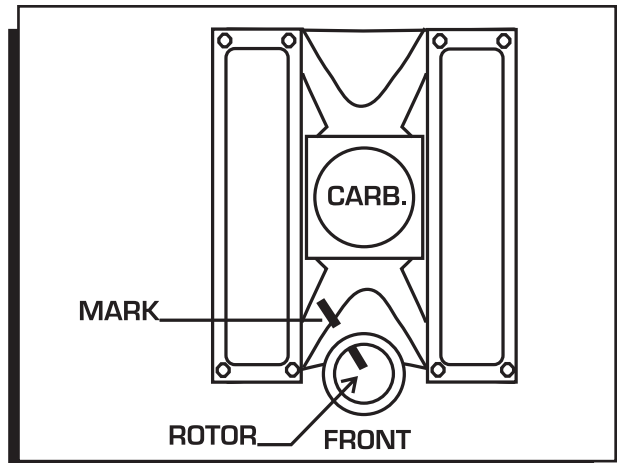

Figure 8 Marking the Rotor Location.

ADJUSTING THE COLLAR

1. Install the Gear-Setting spacer onto the shaft and use the set screw to hold it in place (Figure 9). Also install the distributor gasket.
2. Use a 3/26" Allen Wrench to loosen the locking screw on the Adjustable Hold Down Clamp (Figure 10).
3. Set the distributor into the engine block and allow the Gear-Setting spacer to rest on the cam gear.
4. Once the distributor is in place, position the Adjustable Hold Down Clamp in place on the housing and tighten the locking screw.
5. After tightening the Adjustable Hold Down Clamp, pull the distributor out of the engine.
6. Remove the Gear-Setting spacer from the shaft and install the gear with the supplied roll pin.

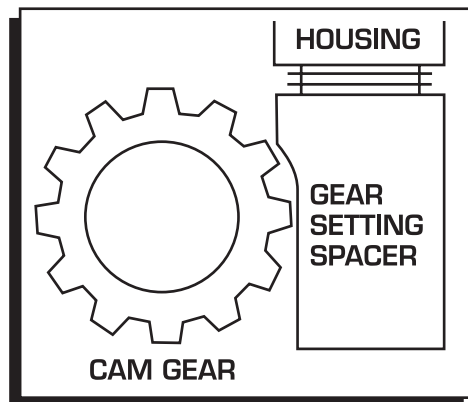

Figure 9 Adjusting the Gear Setting.

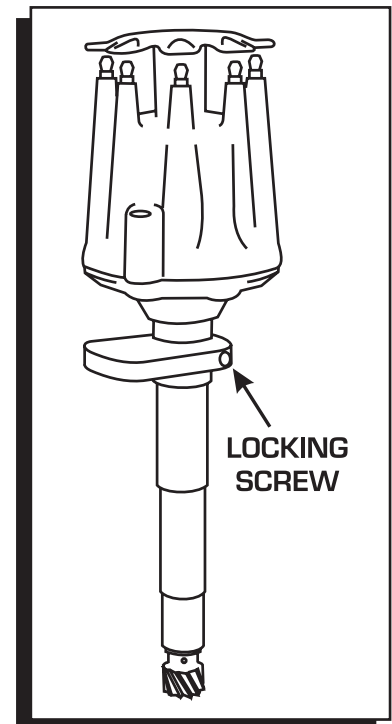

Figure 10 Adjusting the Hold Down Clamp.

INSTALLATION

1. Apply a liberal amount of the supplied lubricant to the distributor gear.
2. Install the distributor making sure that the rotor comes to rest pointing at the fixed mark.
3. Position and tighten the hold down clamp onto the distributor.
4. Install the distributor cap and spark plug wires one at a time to ensure correct location. A wire retainer is supplied to secure the wires in place. Align the mounting bosses and use the supplied 1.5" self-tapping Phillips screws to hold the retainer in place.
5. Page 8 shows how to set the rev limiter and connect the tachometer.

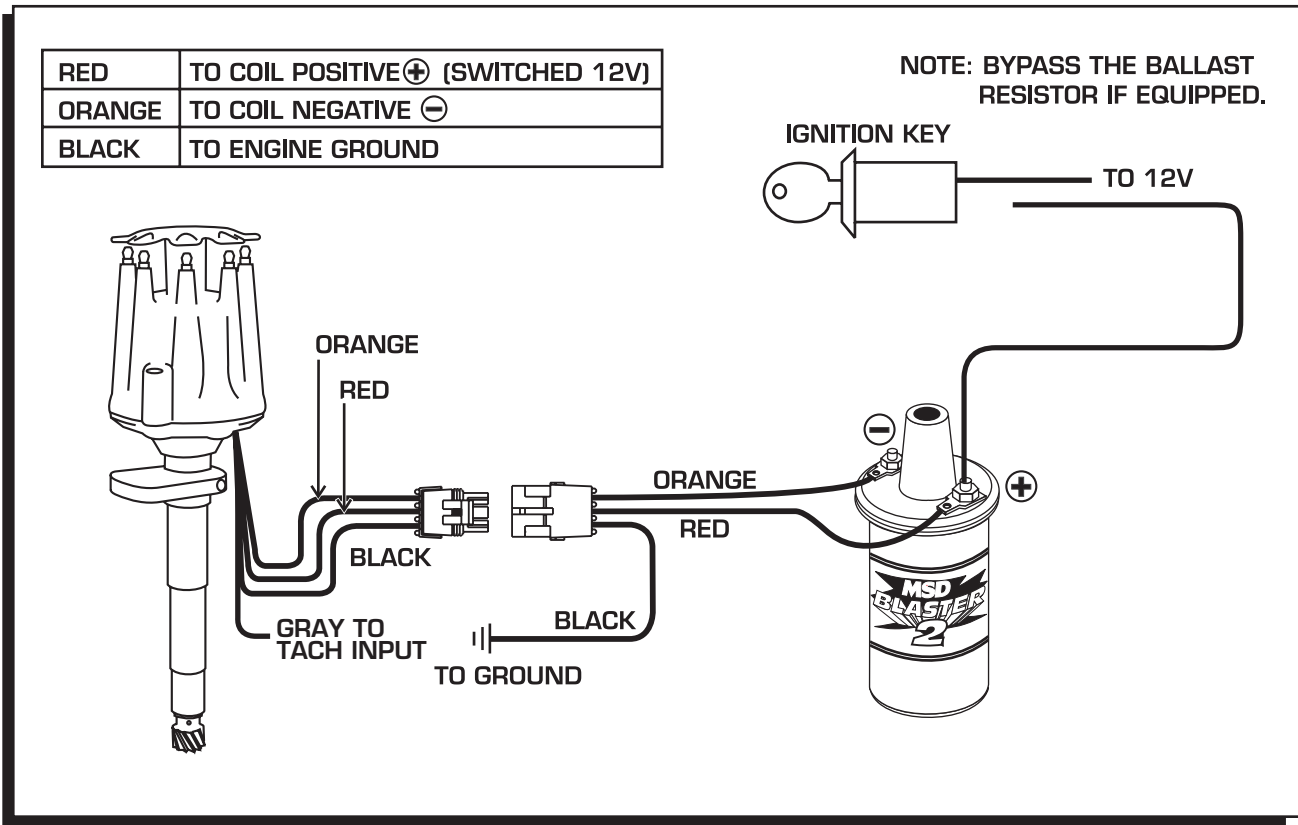

Figure 11 Wiring the Ready-to-Run Distributor.

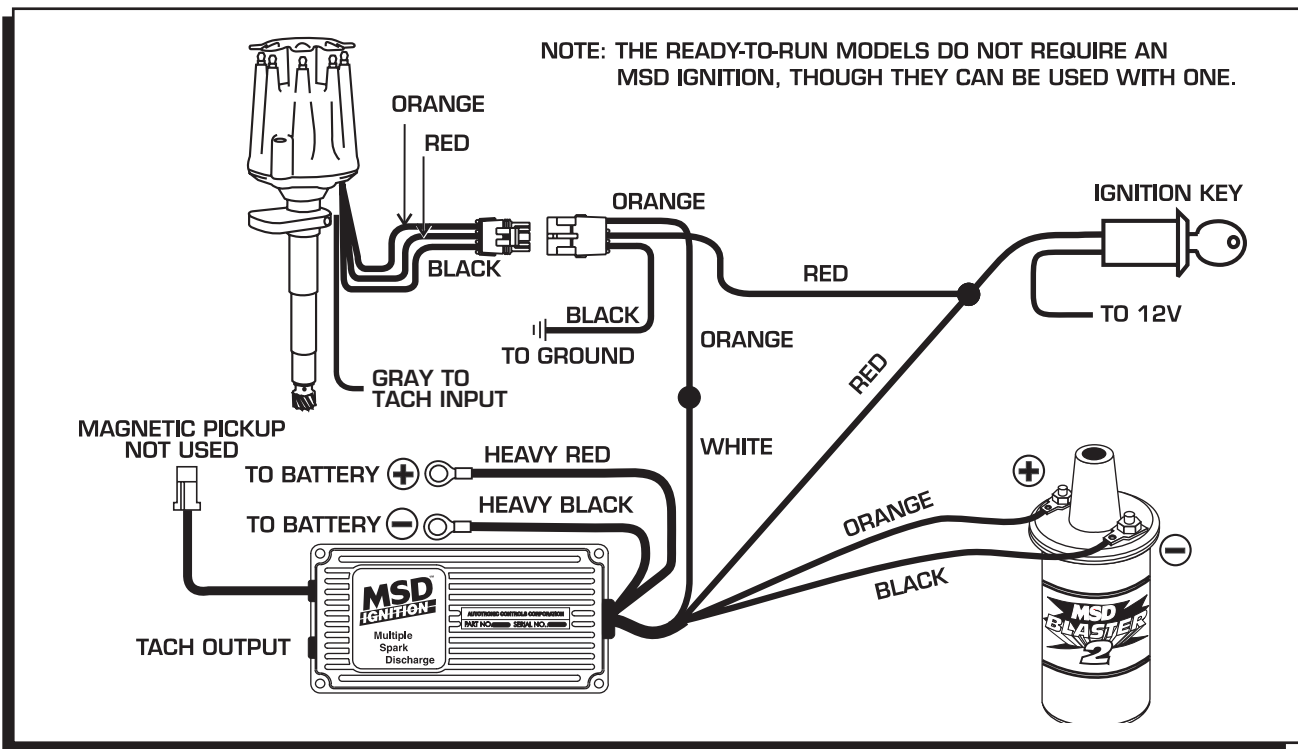

Figure 12 Connecting an MSD Ignition Control to the Ready-to-Run Distributor.

VACUUM ADVANCE LOCKOUT

If you do not want to use the vacuum advance canister, MSD has supplied the distributor with a lockout mechanism. The Lockout bolts in the position of the vacuum canister and will hold the pickup assembly firmly in place. The installation is easiest with the distributor out of the engine.

1. Remove the two Allen head screws that hold the advance canister (Figure 13).
2. Remove the snap ring that holds the magnetic pickup assembly in place. This is easy to do with a set of snap ring pliers by straddling one of the reluctor paddles.
3. Gently lift up on the mag pickup plate and slide the vacuum canister out.
4. Install the Lockout Plate in place of the canister. Install the two retaining screws.
5. Install the supplied screw and washer through the Lockout and tighten.
6. It is important to make sure the pickup plate is parallel with the housing of the distributor (Figure 14). If it is cocked or slanted, the paddles of the reluctor may contact the pickup. Check the clearance by rotating the distributor shaft. If necessary, use the supplied shims under the Lockout hold-down to correctly position the pickup plate.

Note: If no shims were required, use one beneath the washer of the Lock-Out Hold Down Screw.

7. After checking the reluctor to pickup clearance, tighten the Lockout retaining screws and install the snap ring.
8. Install the distributor, rotor and cap. Check the timing when complete.

Note: Do not forget to plug the original vacuum advance hose.

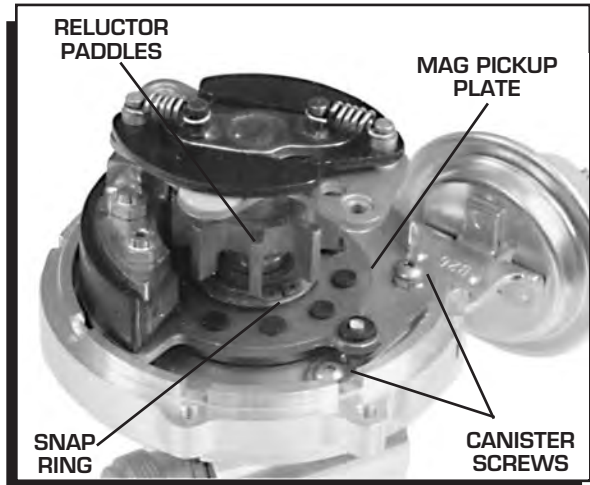

Figure 13 Removing the Vacuum Canister.

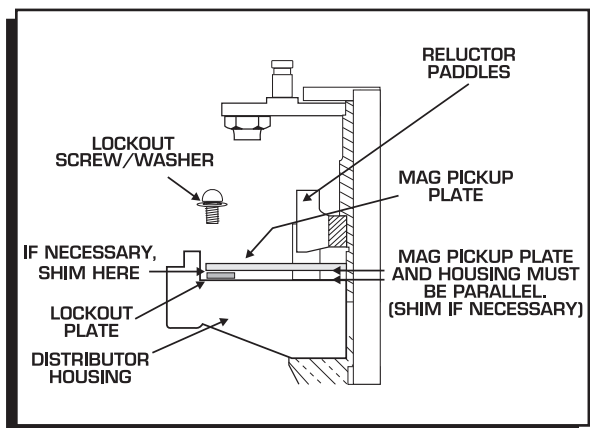

Figure 14 Checking Installation of the Lockout Plate.

Installation Option: This Cap can also be bolted down to an MSD Pro-Billet or Billet Distributor base with the supplied hardware. To accomplish this, the spring clips must be cut off (Figure 15).

Note: When the cap is bolted down, the location of the spark plug wires must be changed.

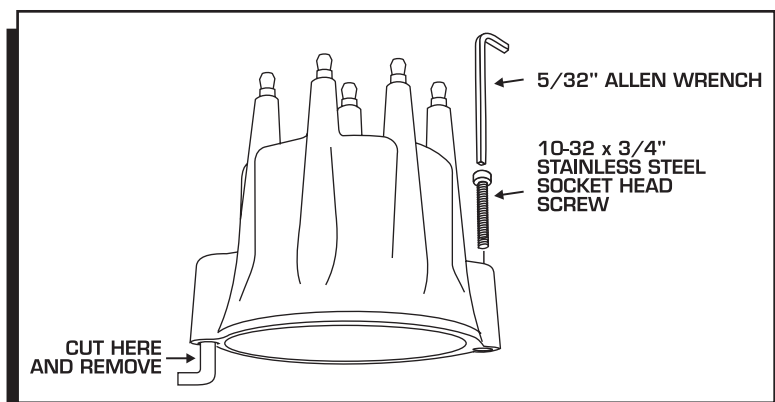

Figure 15 Optional Installation by Bolting the Cap Down.

MSD IGNITION INSTALLATION INSTRUCTIONS

TACHOMETER INFORMATION

The MSD Ready-to-Run has a Gray wire that provides a 12 volt square wave, 20° duty cycle tachometer signal that will trigger most tachometers. It is recommended to connect this lead to your tach's trigger input wire and check its operation. Note that the rpm limiter is extremely accurate and due to the variety of tachometers available, there may be differences in the displayed rpm.

PROGRAMMING THE REV LIMIT

A tachometer is required to set the rev limit. The limit is programmed by running the engine at half the desired rpm, then momentarily grounding the Gray tach output wire from the MSD. A Gray jumper wire is supplied to connect to the tach with another tee-splice coming off to use for programming. A switch may also be installed to ease adjustments of the limiter (Figure 16). The default rpm limit is 10,000 rpm and the limit is adjustable from 2,000 - over 10,000 rpm..

1. Start the engine and bring the rpm to half the desired rev limit (for a 6,000 rpm limit, raise and hold the rpm to 3,000).
2. While holding the rpm steady, short the Gray tach wire to ground for approximately one second. Note that the tach will go to zero while grounded.
3. The tach will now display the programmed rev limit amount for two seconds. If this value does not register on the tach, repeat the procedure and try a different ground source.
4. To confirm the rev limit value, turn the ignition key to the On position (without cranking the engine). The rev limit value will be displayed for two seconds on the tachometer.

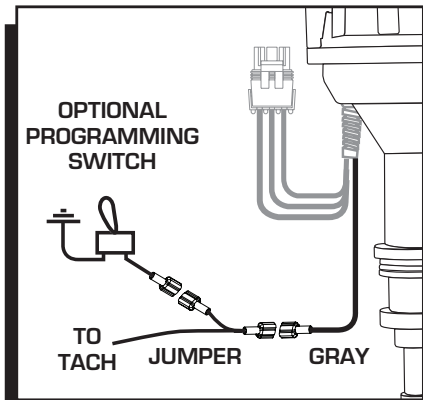

Figure 16 Setting the Rev Limiter.

Note: This rpm confirmation only displays when the Gray wire is being used to trigger the tachometer.

Service

In case of malfunction, this MSD component will be repaired free of charge according to the terms of the warranty. When returning MSD components for warranty service, **Proof of Purchase** must be supplied for verification. After the warranty period has expired, repair service is based on a minimum and maximum fee.

All returns must have a Return Material Authorization (RMA) number issued to them before being returned. To obtain an RMA number please contact MSD Customer Service at 1 (888) MSD-7859 or visit our website at www.msdisignition.com/rma to automatically obtain a number and shipping information.

When returning the unit for repair, leave all wires at the length in which you have them installed. Be sure to include a detailed account of any problems experienced, and what components and accessories are installed on the vehicle. The repaired unit will be returned as soon as possible using Ground shipping methods (ground shipping is covered by warranty). For more information, call MSD Ignition at (915) 855-7123. MSD technicians are available from 7:00 a.m. to 5:00 p.m. Monday - Friday (mountain time).

Limited Warranty

MSD IGNITION warrants this product to be free from defects in material and workmanship under its intended normal use*, when properly installed and purchased from an authorized MSD dealer, for a period of one year from the date of the original purchase. This warranty is void for any products purchased through auction websites. If found to be defective as mentioned above, it will be repaired or replaced at the option of MSD Ignition. Any item that is covered under this warranty will be returned free of charge using Ground shipping methods.

This shall constitute the sole remedy of the purchaser and the sole liability of MSD Ignition. To the extent permitted by law, the foregoing is exclusive and in lieu of all other warranties or representation whether expressed or implied, including any implied warranty of merchantability or fitness. In no event shall MSD Ignition or its suppliers be liable for special or consequential damages.

*Intended normal use means that this item is being used as was originally intended and for the original application as sold by MSD Ignition. Any modifications to this item or if it is used on an application other than what MSD Ignition markets the product, the warranty will be void. It is the sole responsibility of the customer to determine that this item will work for the application they are intending. MSD Ignition will accept no liability for custom applications.