

MSDTM IGNITION

INSTALLATION INSTRUCTIONS

E-Z Adjust Crank Trigger Kit, PN 8605

Parts Included:

1 – Socket Head Cap Screw, 1/4-20 x 3.5"	1 – Mounting Plate
2 – 10-32 Set Screws	1 – Anchor Block
1 – Threaded Hex Mount	1 – Shoulder Screw, 10-24 x .500"
1 – Unthreaded Hex Mount	1 – Button Head Cap Screw, 10-24 x .250"

Note: The E-Z Adjust Kit will fit most popular MSD Flying Magnet Crank Trigger Brackets. It will not work with the PN 8600, 6.25" SB Chevy Kit or the PN 8630, Buick V6 kit.

The E-Z Adjust provides a precise way to easily make incremental timing adjustments. The kit is supplied with two hex mounts, one threaded, the other is not. The location of the mounts determines whether the adjusting screw will be accessible from above or below the vehicle. It will be easier to remove the pickup bracket assembly from the engine to install the Adjuster. Also, determine if you prefer to adjust the timing from above or below. Figure 1 shows the complete assembly with the adjustment made from above.

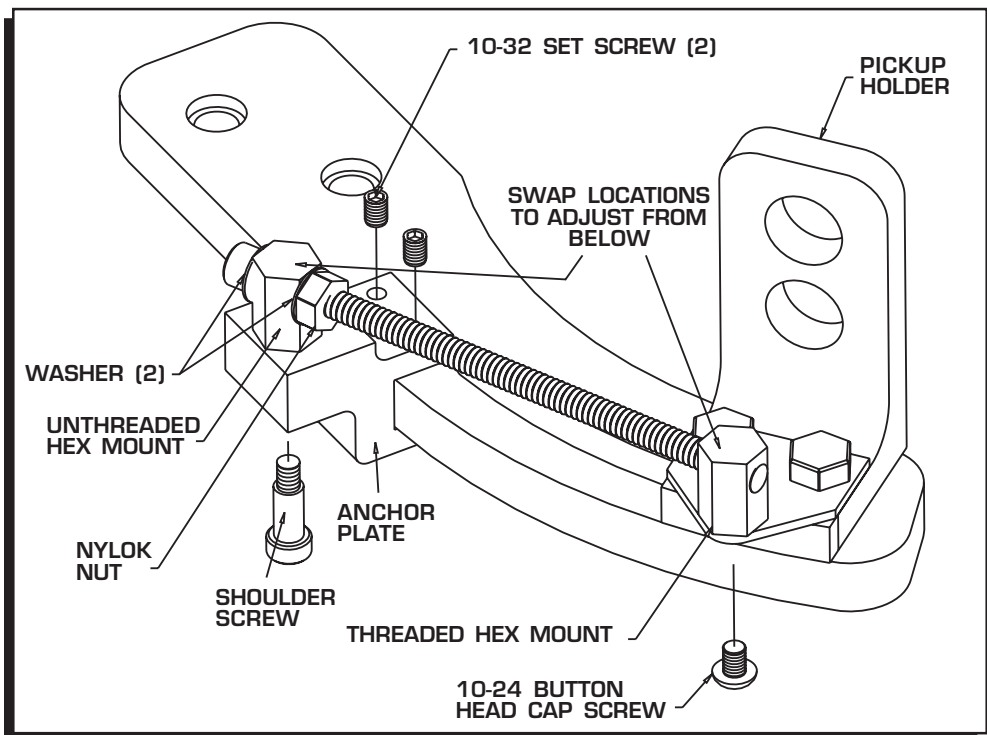

Figure 1 Assembling the E-Z Adjust Crank Trigger Kit.

1. Assemble the adjusting screw by installing a washer, then running it through the unthreaded hex mount. Install the other washer followed by the Nylok nut and run it up until the assembly is snug.
2. Install the hex mount with the adjusting screw to the anchor plate using the Button Head Cap Screw.
3. Remove the pickup holder and install the mounting plate.
4. Install the threaded hex mount to the end of the adjusting screw assembly. Secure the mount to the mounting plate on the pickup holder with the Shoulder Screw.
5. Position the anchor plate to the crank trigger bracket. Its placement can be adjusted by moving adjusting screw. Once the placement is set, install the two set-screws to hold it in place. Blue Loc-Tite is recommended on the set screws.



INSTALLATION INSTRUCTIONS

Service

In case of malfunction, this MSD component will be repaired free of charge according to the terms of the warranty. When returning MSD components for service, Proof of Purchase must be supplied for warranty verification. After the warranty period has expired, repair service is charged based on a minimum and maximum charge.

Send the unit prepaid with proof of purchase to the attention of: **Customer Service Department, Autotronic Controls Corporation, 12120 Esther Lama, Suite 114, El Paso, Texas 79936.**

When returning the unit for repair, leave all wires at the length in which you have them installed. Be sure to include a detailed account of any problems experienced, and what components and accessories are installed on the vehicle.

The repaired unit will be returned as soon as possible after receipt, COD for any charges. (Ground shipping is covered by warranty). All units are returned regular UPS unless otherwise noted. For more information, call the MSD Customer Service Line (915) 855-7123. MSD technicians are available from 8:00 a.m. to 5:00 p.m. Monday - Friday (mountain time).

Limited Warranty

Autotronic Controls Corporation warrants MSD Ignition products to be free from defects in material and workmanship under normal use and if properly installed for a period of one year from date of purchase. If found to be defective as mentioned above, it will be replaced or repaired if returned prepaid along with proof of date of purchase. This shall constitute the sole remedy of the purchaser and the sole liability of Autotronic Controls Corporation. To the extent permitted by law, the foregoing is exclusive and in lieu of all other warranties or representations whether expressed or implied, including any implied warranty of merchantability or fitness. In no event shall Autotronic Controls Corporation be liable for special or consequential damages.