

# MSD IGNITION INSTALLATION INSTRUCTIONS

## MSD Dual DIS-4 Harness PN 88813

### Parts Included:

8 - Individual Cylinder Harnesses

### Additional Parts Required:

4 - Ignition Adapters PN 89121

2 - DIS-4 Ignitions (PN 62152 or High Output PN 62153)

**WARNING:** During installation, disconnect the battery cables. When disconnecting the battery always remove the Negative cable first and install it last.

**Note:** It is recommended that you have the Service Manual and wiring diagram for your vehicle before beginning the installation of the MSD DIS Ignition.

Figure 1 shows the firing order for a Ford Modular motor. This chart contains MSD's recommendations for triggering the Dual DIS-4's versus Firing Order. See Figure 7 for Cylinder Identification.

FIRING ORDER	DIS-4 BOX A OR B	CHANNEL
1	A	1
3	B	1
7	A	2
2	B	2
6	A	3
5	B	3
4	A	4
8	B	4

Figure 1

### WIRING

The Adapter has six wires that need to be connected. The chart shows each wire's application. Figure 2 shows how to wire the Adapter to the DIS ignitions.

WIRING	
<b>BLACK</b>	Connects to Ground.
<b>RED</b>	Connects to 12 volt (Ignition).
INPUTS	
<b>BROWN/WHITE</b>	Connects to the White wire going to the Coils and ECU.
<b>BROWN/GREEN</b>	Connects to the Green wire going to the Coils and ECU.
OUTPUTS	
<b>WHITE</b>	Connects to the White wire going to the MSD DIS Ignition.
<b>GREEN</b>	Connects to the Green wire going to the MSD DIS Ignition.

**Note:** The procedure shown in Figure 2 will be performed twice for each DIS-4 Ignition PN 62152 (or H.O. PN 62153).

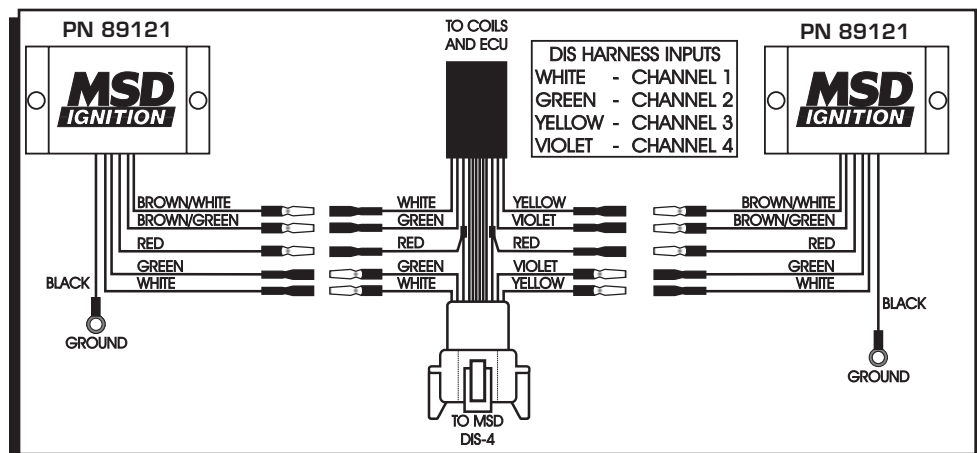

Figure 2 Installation to an MSD DIS-4 Ignition.

**SOHC BOX A**

NOTES: This wiring diagram applies only to SOHC applications. Please refer to figure 5 and 6 for DOHC models.

This wiring diagram applies to cylinders 1, 7, 6 and 4. Please refer to Figure 4 for cylinders 3, 2, 5 and 8.

**WIRE COLOR CODE**

- Brown/White - Coil (-) Channel 1
- Brown/Green - Coil (-) Channel 2
- Brown/Yellow - Coil (-) Channel 3
- Brown/Violet - Coil (-) Channel 4
- Brown/Orange - Coil (+) High Voltage
- White - Trigger Input Channel 1
- Green - Trigger Input Channel 2
- Yellow - Trigger Input Channel 3
- Violet - Trigger Input Channel 4
- Red - Ignition 12 Volt (Switched)
- Pink - Step Retard (to 12 Volts)
- Blue - Two Step (to 12 Volts)
- Brown - No Spark output when Grounded
- Red (Heavy) - Battery (+)
- Black (Heavy) - Battery (-)

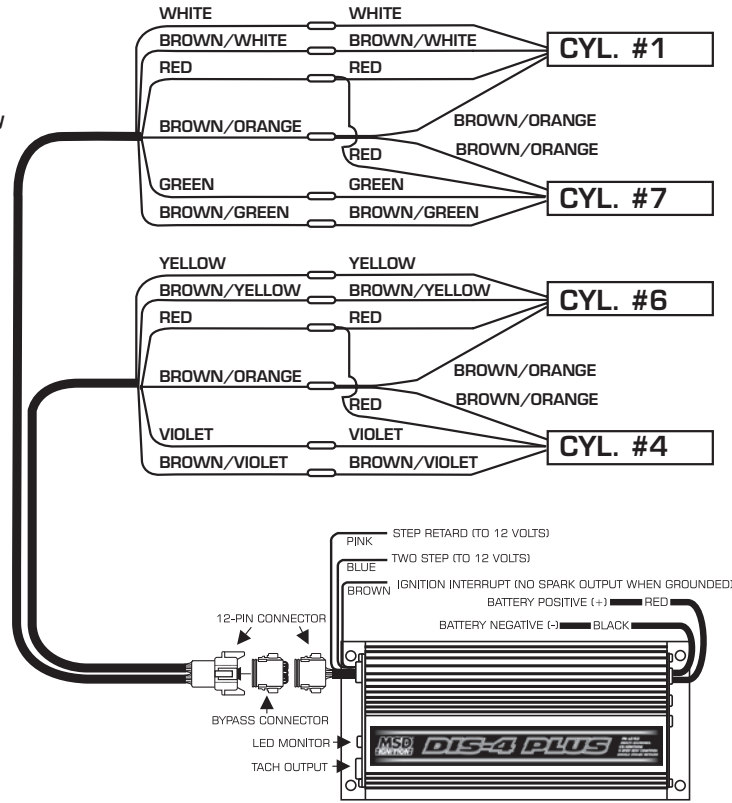

Figure 3

**SOHC BOX B**

NOTES: This wiring diagram applies only to SOHC applications. Please refer to figure 5 and 6 for DOHC models.

This wiring diagram applies to cylinders 3, 2, 5 and 8. Please refer to Figure 3 for cylinders 1, 7, 6 and 4.

**WIRE COLOR CODE**

- Brown/White - Coil (-) Channel 1
- Brown/Green - Coil (-) Channel 2
- Brown/Yellow - Coil (-) Channel 3
- Brown/Violet - Coil (-) Channel 4
- Brown/Orange - Coil (+) High Voltage
- White - Trigger Input Channel 1
- Green - Trigger Input Channel 2
- Yellow - Trigger Input Channel 3
- Violet - Trigger Input Channel 4
- Red - Ignition 12 Volt (Switched)
- Pink - Step Retard (to 12 Volts)
- Blue - Two Step (to 12 Volts)
- Brown - No Spark output when Grounded
- Red (Heavy) - Battery (+)
- Black (Heavy) - Battery (-)

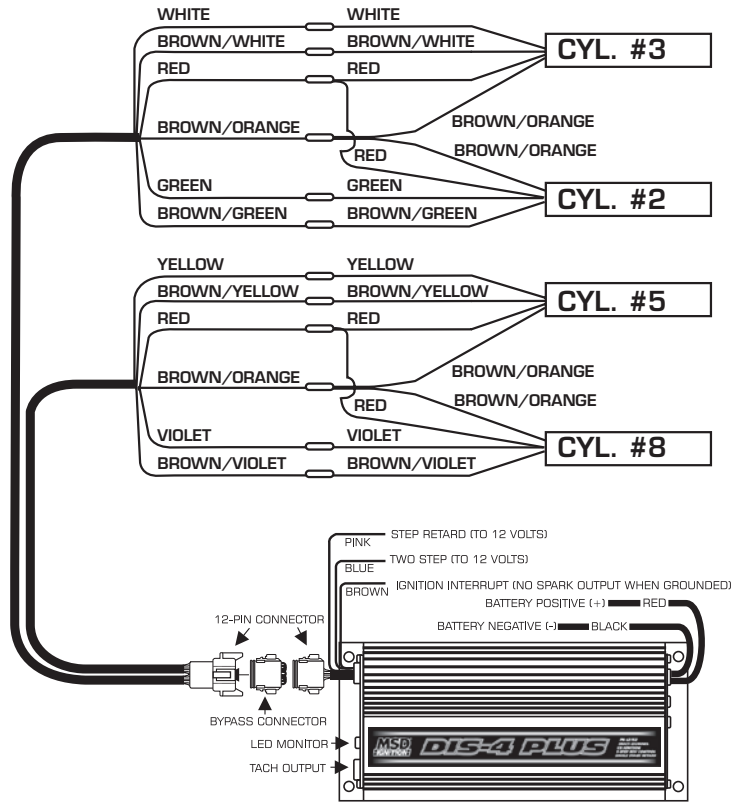

Figure 4

**DOHC BOX A**

NOTES: This wiring diagram applies only to DOHC applications. Please refer to figure 3 and 4 for SOHC models.

This wiring diagram applies to cylinders 1, 7, 6 and 4. Please refer to Figure 6 for cylinders 3, 2, 5 and 8.

**WIRE COLOR CODE**

- Brown/White - Coil (-) Channel 1
- Brown/Green - Coil (-) Channel 2
- Brown/Yellow - Coil (-) Channel 3
- Brown/Violet - Coil (-) Channel 4
- Brown/Orange - Coil (+) High Voltage
- White - Trigger Input Channel 1
- Green - Trigger Input Channel 2
- Yellow - Trigger Input Channel 3
- Violet - Trigger Input Channel 4
- Red - Ignition 12 Volt (Switched)
- Pink - Step Retard (to 12 Volts)
- Blue - Two Step (to 12 Volts)
- Brown - No Spark output when Grounded
- Red (Heavy) - Battery (+)
- Black (Heavy) - Battery (-)

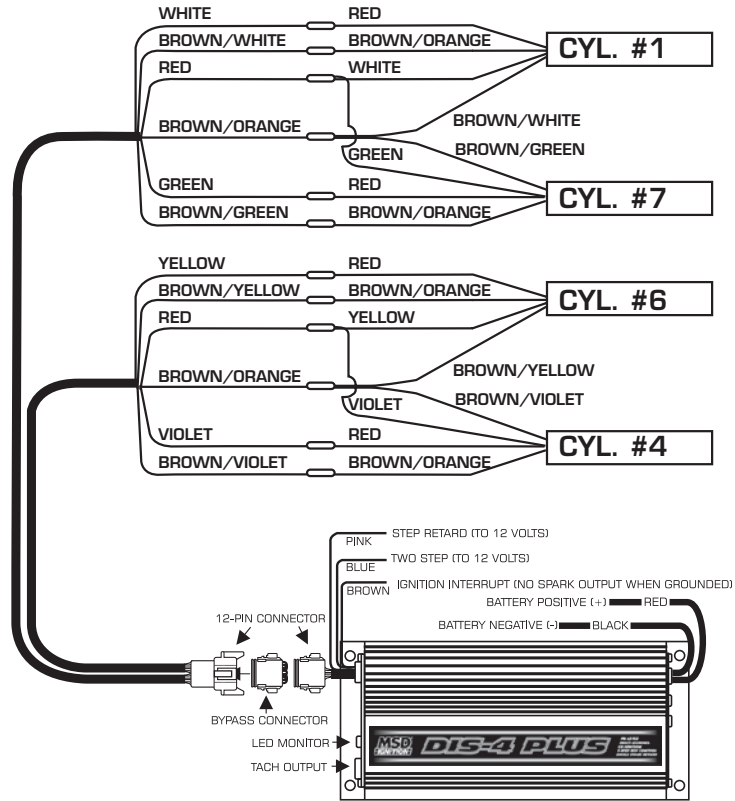

Figure 5

**DOHC BOX B**

NOTES: This wiring diagram applies only to DOHC applications. Please refer to figure 3 and 4 for SOHC models.

This wiring diagram applies to cylinders 3, 2, 5 and 8. Please refer to Figure 5 for cylinders 1, 7, 6 and 4.

**WIRE COLOR CODE**

- Brown/White - Coil (-) Channel 1
- Brown/Green - Coil (-) Channel 2
- Brown/Yellow - Coil (-) Channel 3
- Brown/Violet - Coil (-) Channel 4
- Brown/Orange - Coil (+) High Voltage
- White - Trigger Input Channel 1
- Green - Trigger Input Channel 2
- Yellow - Trigger Input Channel 3
- Violet - Trigger Input Channel 4
- Red - Ignition 12 Volt (Switched)
- Pink - Step Retard (to 12 Volts)
- Blue - Two Step (to 12 Volts)
- Brown - No Spark output when Grounded
- Red (Heavy) - Battery (+)
- Black (Heavy) - Battery (-)

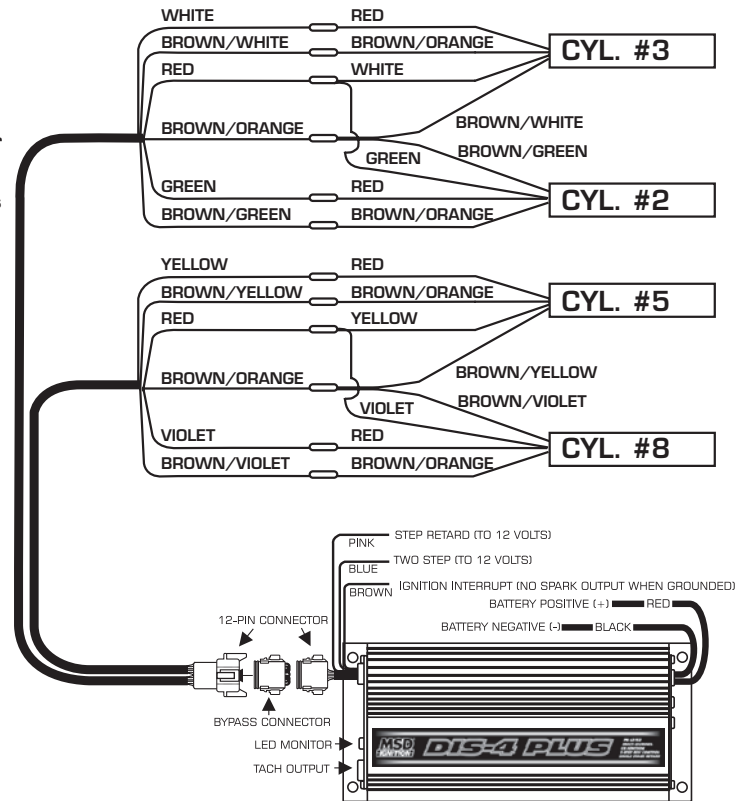
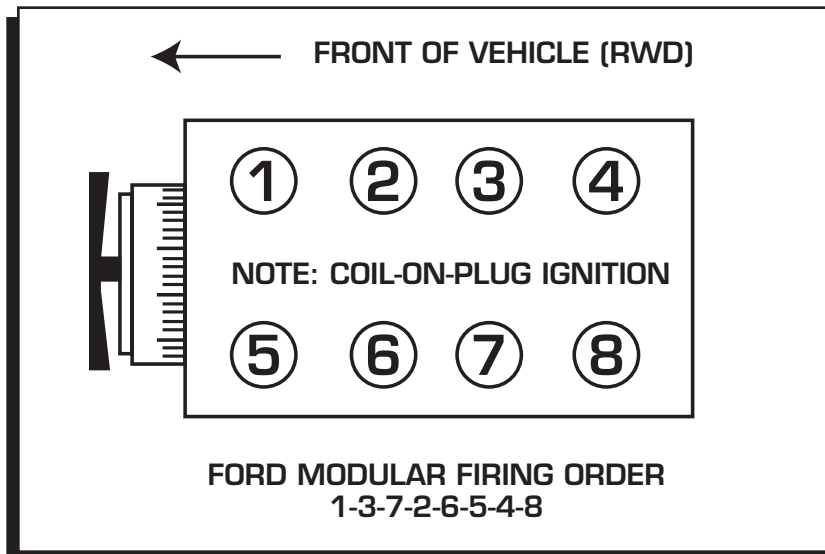

Figure 6



**Figure 7 Cylinder Identification.**

### Service

In case of malfunction, this MSD component will be repaired free of charge according to the terms of the warranty. When returning MSD components for warranty service, **Proof of Purchase** must be supplied for verification. After the warranty period has expired, repair service is based on a minimum and maximum fee.

**All returns must have a Return Material Authorization (RMA) number** issued to them before being returned. To obtain an RMA number please contact MSD Customer Service at 1 (888) MSD-7859 or visit our website at [www.msdisignition.com/rma](http://www.msdisignition.com/rma) to automatically obtain a number and shipping information.

When returning the unit for repair, leave all wires at the length in which you have them installed. Be sure to include a detailed account of any problems experienced, and what components and accessories are installed on the vehicle. The repaired unit will be returned as soon as possible using Ground shipping methods (ground shipping is covered by warranty). For more information, call MSD Ignition at (915) 855-7123. MSD technicians are available from 7:00 a.m. to 6:00 p.m. Monday - Friday (mountain time).

### Limited Warranty

MSD IGNITION warrants this product to be free from defects in material and workmanship under its intended normal use\*, when properly installed and purchased from an authorized MSD dealer, for a period of one year from the date of the original purchase. This warranty is void for any products purchased through auction websites. If found to be defective as mentioned above, it will be repaired or replaced at the option of MSD Ignition. Any item that is covered under this warranty will be returned free of charge using Ground shipping methods.

This shall constitute the sole remedy of the purchaser and the sole liability of MSD Ignition. To the extent permitted by law, the foregoing is exclusive and in lieu of all other warranties or representation whether expressed or implied, including any implied warranty of merchantability or fitness. In no event shall MSD Ignition or its suppliers be liable for special or consequential damages.

\*Intended normal use means that this item is being used as was originally intended and for the original application as sold by MSD Ignition. Any modifications to this item or if it is used on an application other than what MSD Ignition markets the product, the warranty will be void. It is the sole responsibility of the customer to determine that this item will work for the application they are intending. MSD Ignition will accept no liability for custom applications.