

MSD[®] IGNITION INSTALLATION INSTRUCTIONS

MSD Shift Light PN 8952

Parts Included:

1 - Shift Light	6 - Heat-Shrink Sleeves
1 - Rubber Grommet	2 - Mounting Screws

Note: RPM Modules are not supplied. A chart of Module Kits is listed at the end of these instructions.

WIRING

Red	Connect to switched 12 volts.
Black	Connect to Ground.
Green	RPM Input wire. Connect it to the tach output terminal of an MSD Ignition Control. On factory inductive ignitions (without an MSD), connect to the coil negative terminal.

Note: Whenever the ignition is turned On, the Shift Light will illuminate for a couple seconds to indicate that it is operational. If it does not light, check all of the wiring connections and for voltage on the Red wire.

CYLINDER SELECT WIRES

The MSD Shift Light is programmed for operation on 8-cylinder engines. To program it for use on other engines, cut the correct wire loop(s) as shown in Figure 1. Seal the cut wire ends with the supplied heat-shrink sleeves.

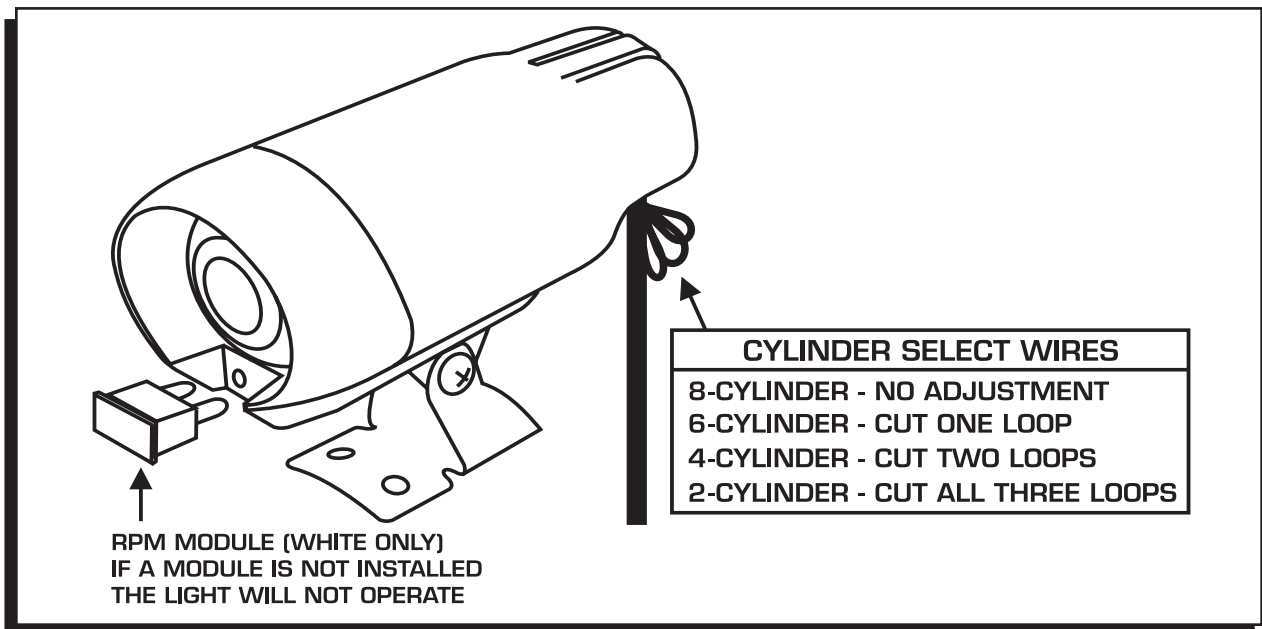

Figure 1 Cylinder Select of the Shift Light.

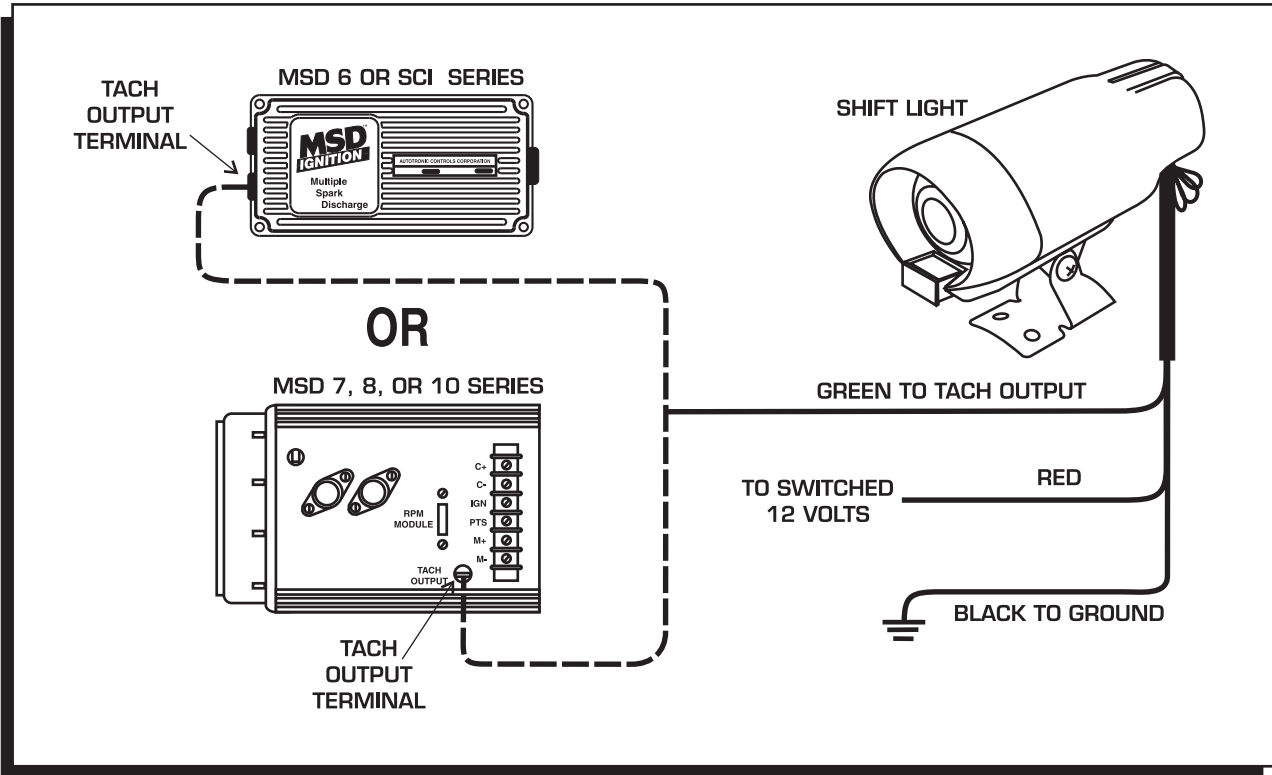
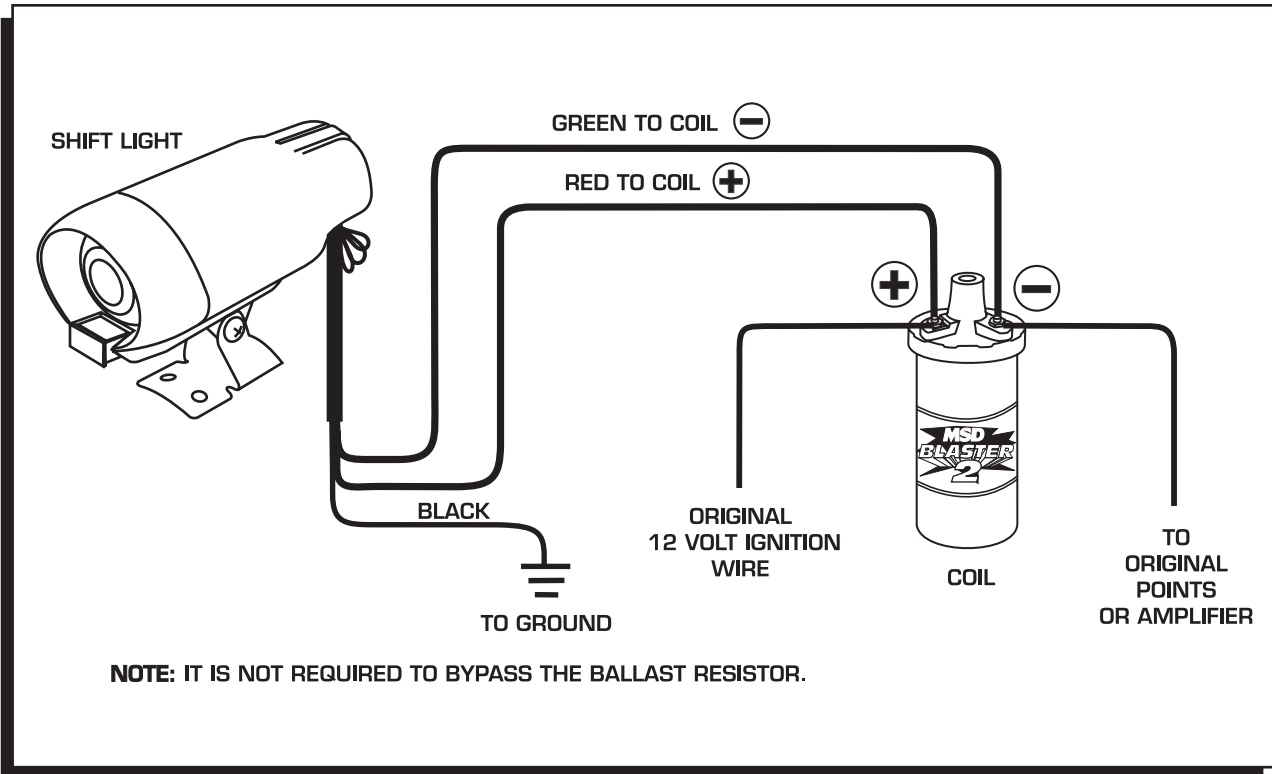

Figure 2 Wiring with an MSD Ignition Control.



NOTE: IT IS NOT REQUIRED TO BYPASS THE BALLAST RESISTOR.

Figure 3 Wiring to a Points or Amplifier Ignition (non-MSD system).

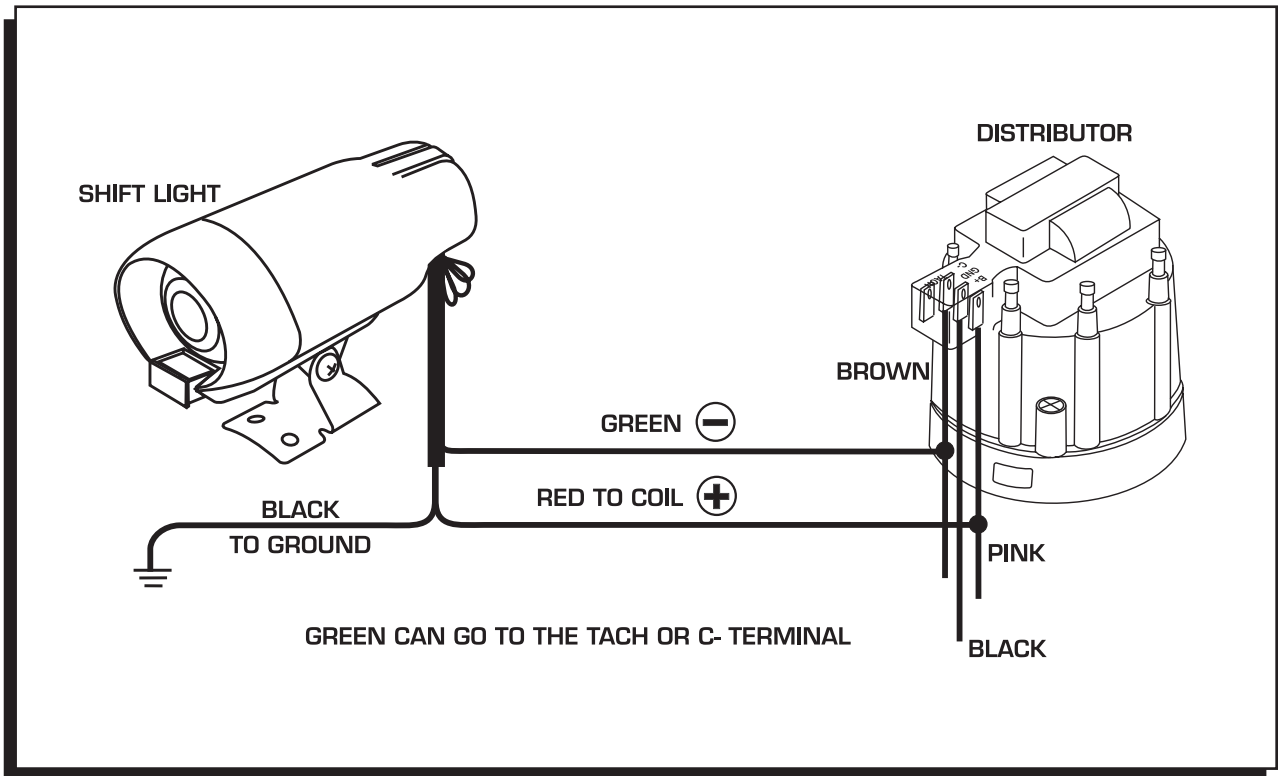

Figure 4 Wiring to a GM HEI Distributor.

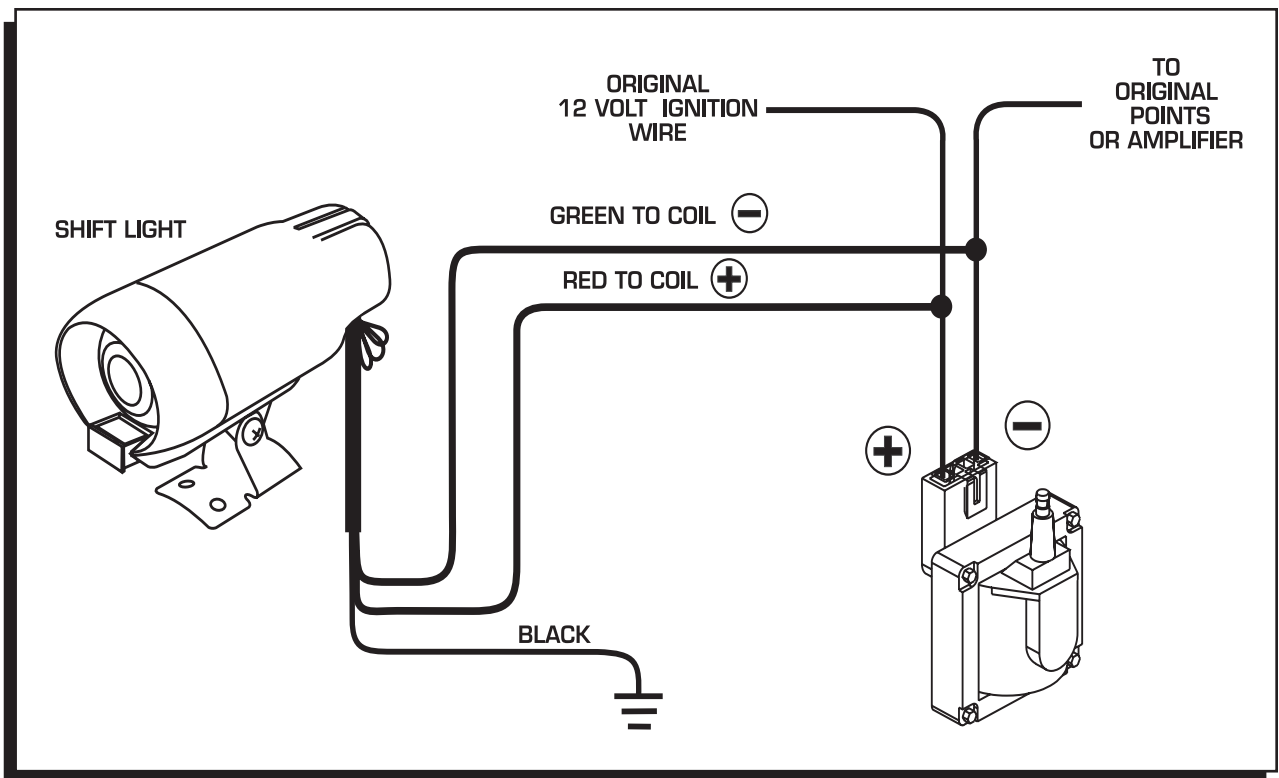

Figure 5 Wiring to a Ford TFI Coil.

MSD IGNITION® INSTALLATION INSTRUCTIONS

RPM MODULE KITS

EVEN INCREMENTS		ODD INCREMENTS	
3,000-3,800	PN 8743	3,100-3,900	PN 87431
4,000-4,800	PN 8744	4,100-4,900	PN 87441
5,000-5,800	PN 8745	5,100-5,900	PN 87451
6,000-6,800	PN 8746	6,100-6,900	PN 87461
7,000-7,800	PN 8747	7,100-7,900	PN 87471
8,000-8,800	PN 8748	8,100-8,900	PN 87481
9,000-9,800	PN 8749	9,100-9,900	PN 87491
10,000-10,800	PN 8750	10,100-10,900	PN 87501
11,000-11,800	PN 8751	11,100-11,900	PN 87511
12,000-12,800	PN 8752	12,100-12,900	PN 87521
13,000-13,800	PN 8753	13,100-13,900	PN 87531

Kits are supplied with five modules in 200 rpm increments.

RPM MODULE SELECTORS

3,000-5,200	PN 8670
4,600-6,800	PN 8671
6,000-8,200	PN 8672
7,600-9,800	PN 8673
9,000-11,200	PN 8674
10,600-12,800	PN 8675

RPM Selectors feature a dial that allows you to choose between 12 different rpm limits in 200 rpm increments.

Service

In case of malfunction, this MSD component will be repaired free of charge according to the terms of the warranty. When returning MSD components for warranty service, **Proof of Purchase** must be supplied for verification. After the warranty period has expired, repair service is based on a minimum and maximum fee.

All returns must have a Return Material Authorization (RMA) number issued to them before being returned. To obtain an RMA number please contact MSD Customer Service at 1 (888) MSD-7859 or visit our website at www.msdisignition.com/rma to automatically obtain a number and shipping information.

When returning the unit for repair, leave all wires at the length in which you have them installed. Be sure to include a detailed account of any problems experienced, and what components and accessories are installed on the vehicle. The repaired unit will be returned as soon as possible using Ground shipping methods (ground shipping is covered by warranty). For more information, call MSD Ignition at (915) 855-7123. MSD technicians are available from 7:00 a.m. to 6:00 p.m. Monday - Friday (mountain time).

Limited Warranty

MSD IGNITION warrants this product to be free from defects in material and workmanship under its intended normal use*, when properly installed and purchased from an authorized MSD dealer, for a period of one year from the date of the original purchase. This warranty is void for any products purchased through auction websites. If found to be defective as mentioned above, it will be repaired or replaced at the option of MSD Ignition. Any item that is covered under this warranty will be returned free of charge using Ground shipping methods.

This shall constitute the sole remedy of the purchaser and the sole liability of MSD Ignition. To the extent permitted by law, the foregoing is exclusive and in lieu of all other warranties or representation whether expressed or implied, including any implied warranty of merchantability or fitness. In no event shall MSD Ignition or its suppliers be liable for special or consequential damages.

*Intended normal use means that this item is being used as was originally intended and for the original application as sold by MSD Ignition. Any modifications to this item or if it is used on an application other than what MSD Ignition markets the product, the warranty will be void. It is the sole responsibility of the customer to determine that this item will work for the application they are intending. MSD Ignition will accept no liability for custom applications.