

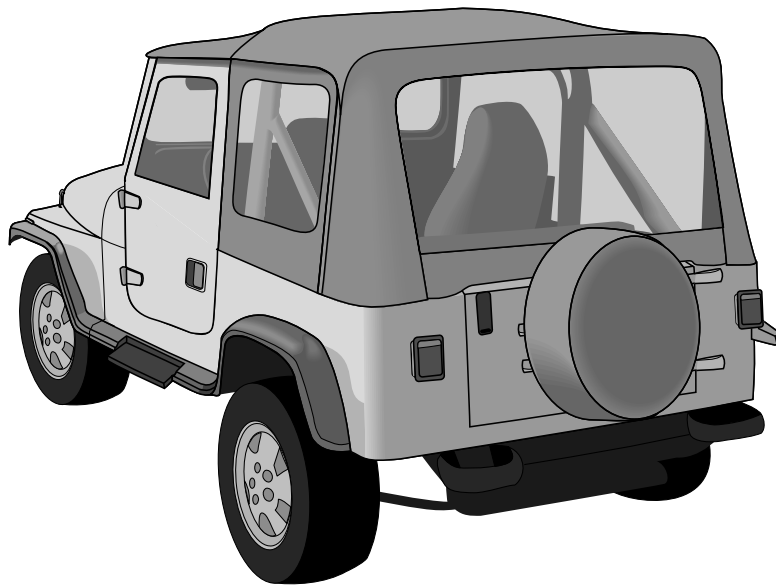

Fliptop Installation Instructions

For: CJ7 '76- '86 and
Wrangler/YJ '86- '95

Part Number: 44523



WARNING

This product is designed to enhance the appearance of the vehicle and to shield the occupants from ordinary weather conditions. The safety characteristics of this product are extremely limited. Do not rely in any way on the components of this product to contain occupants within the vehicle, or to protect against injury or death in the event of an accident. This top will not protect the occupants from falling objects. Never operate vehicle in excess of manufacturer's specifications.

WEAR SEAT BELTS AT ALL TIMES

Read and follow, precisely, all installation instructions provided when installing top. Failure to do so may result in a poor fitting top and could place occupants of the vehicle in a potentially dangerous situation.

Installation Tips

Before you begin installing this Fliptop assembly, read all instructions thoroughly. Below are a few tips to make this installation easier. After completing the installation, keep these instructions for further reference.

For a smooth fit:

For ease in installation, the Fliptop should be installed at temperatures above 72° deg. F.° Below this temperature, the fabric may contract an inch or more, making it difficult to fit to the vehicle.

It is normal for the fabric to contract and wrinkle when stored in the shipping carton. Within a few days after the installation, the fabric will relax and the wrinkles will disappear.

Parts List and Hardware Identification

Top Fabric	Qty - 1
Quarter Window, Rt.	Qty - 1
Quarter Window, Lt.	Qty - 1
Rear Window	Qty - 1
Windshield Header Trim	Qty - 1

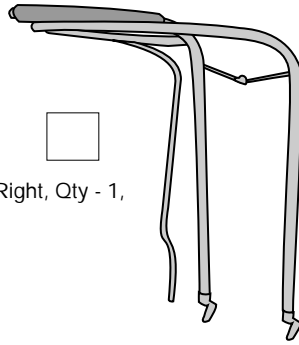
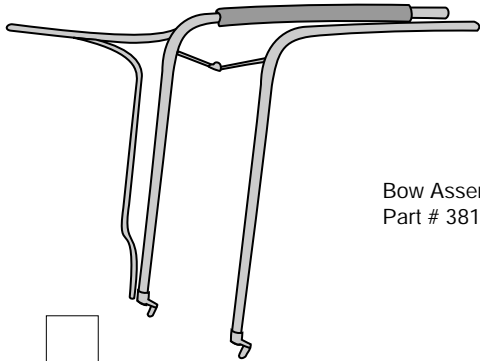
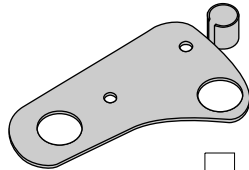
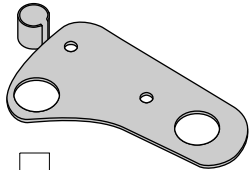
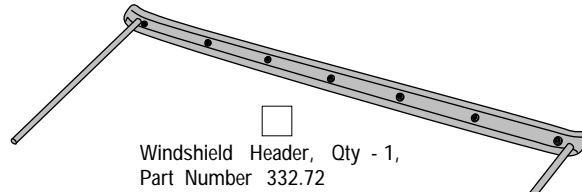

Side Belt Rail - Left, Qty - 1,
Part Number 134.02

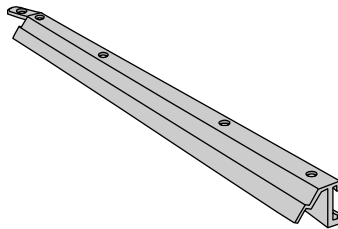

Side Belt Rail - Right, Qty - 1,
Part Number 134.01

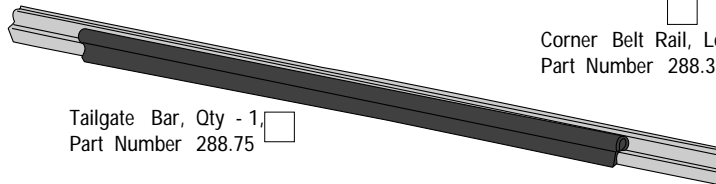
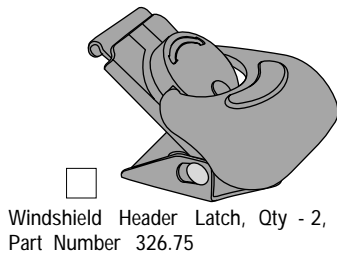
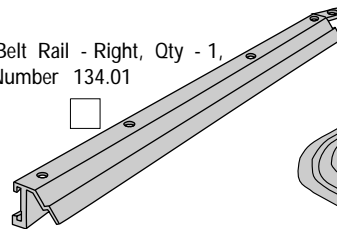

Corner Belt Rail, Left, Qty - 1,
Part Number 288.34

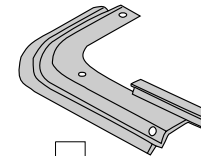

Corner Belt Rail, Right, Qty - 1,
Part Number 288.33

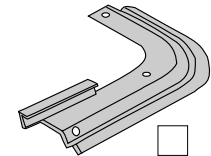

#8 x 1/2" Pan Head Washer Screw - Black, Qty - 2, Part Number 200.48		
#10-15/16 Bolt, Qty - 2, Part Number 326.85		
#10 x 1/2" Pan Head Sheet Metal Screw Qty - 4, Part Number 1.92		
Christmas Tree Fastener, Qty - 12, Part Number 332.07		
#8 x 5/8" Screw, Qty - 4, Part Number 278.13		
Lock Nut, Qty - 2, Part Number 316.94		
5/16" Black Washer, Qty - 12, Part Number 233.04		
5/16-18 Tapping Plate, Qty - 12, Part Number 200.50		
5/16-18 x 1" Phillips Head Bolt, Qty - 12, Part Number 236.20		

CJ7 Only - Wrangler Adjustment on next page



WARNING

Improper windshield adjustment will result in poor fitting top and doors, causing looseness or undue strain on the top.

Note: If you are replacing an old soft top, be certain that all parts of the old top are removed, including the windshield retainer. Old metal parts are not compatible with the new FlipTop. Using parts other than those provided in your FlipTop kit can result in personal injury and/or damage to the vehicle and soft top.

Windshield Measurement

Before installing the top check the windshield measurement. The distance from the top lip of the windshield to the top outer edge of the body must be $75 \frac{1}{8}$ " on both sides of the vehicle. Measure 4"-6" inside the doors.

CJ7 Windshield Adjustment

If necessary, loosen the two screws in the Windshield Clamps at the base of the windshield on each side of the vehicle. Adjust the windshield forward or back, use a shim if needed to position the windshield, and tighten the screws.

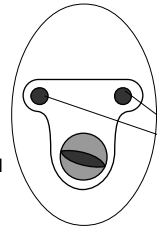

Windshield Clamp Detail

Adjusting Screws - Some Models may require a #40 Torx

Tools Needed - CJ7

1/8", 5/32", 3/8" Drill Bits and Drill Motor
Center Punch
#40 Torx - Optional
Ratchet

Flat Screwdriver
Phillips Screwdriver
Hammer
Pencil
Adjustable Wrench
10' Tape Measure

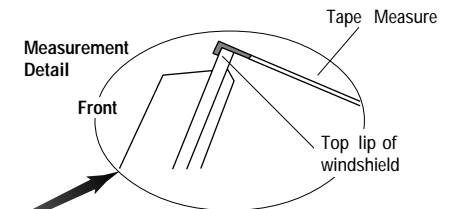

Step One

CJ7: After adjusting the windshield, install the Windshield Brackets. If present, remove the outboard sun visor fasteners on both sides of the windshield frame. Place the Windshield Brackets flush with the frame on the upper corners of the windshield. Use the bracket as a template to mark, center punch and drill two 5/32" holes for each bracket. Mount each bracket to the windshield frame using two #10 x 1/2" Pan Head Sheet Metal Screws Reinstall sun visor brackets.

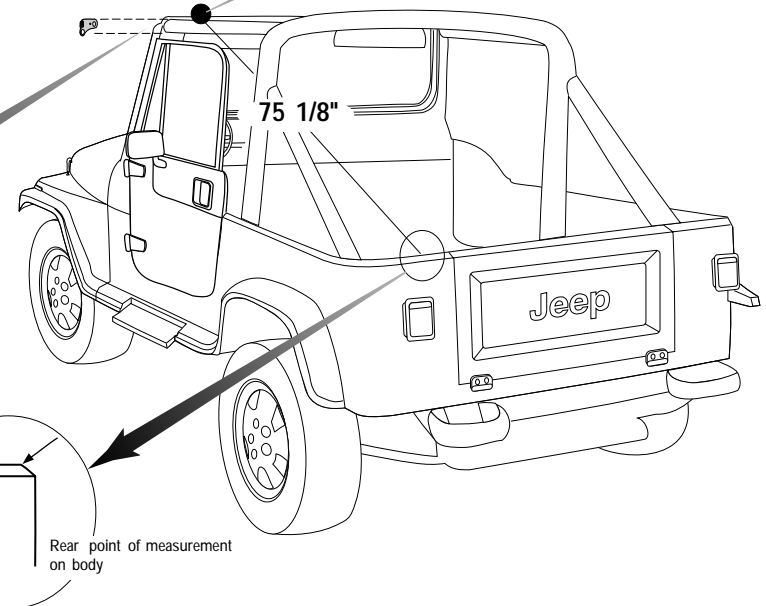
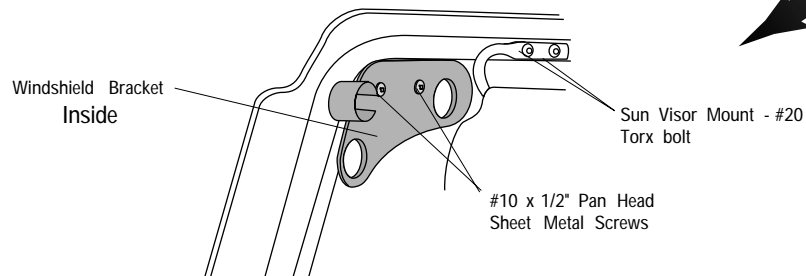

Wrangler Adjustment



WARNING

Improper windshield adjustment will result in poor fitting top and doors, causing looseness or undue strain on the top.

Note: Under most circumstances, the windshield of the Wrangler will not require any adjustment. If your Wrangler windshield should require adjustment, this adjustment should be performed only by an authorized automotive mechanic using a special "Tamper-Proof" Torx head tool.

Windshield Measurement

Before installing the top check the windshield measurement. The distance from the top lip of the windshield to the top outer edge of the body must be 75 1/8" on both sides of the vehicle. Measure 4"-6" inside the doors.

Wrangler YJ Windshield Adjustment

If necessary, loosen the #40 TORX bolts in the windshield clamps to loosen the windshield in order to slip the bracket under the horizontal tube.

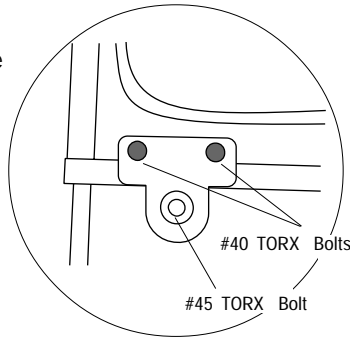

- ### Tools Needed- Wrangler
- 1/8", 7/32", 3/8" Drill Bits
 - and Drill Motor
 - Center Punch
 - Pencil
 - #20 Torx - Optional
 - #35 Torx - Optional
 - #40 Torx - Optional
 - #45 Torx - Optional
 - Flat Screwdriver
 - Phillips Screwdriver
 - Hammer
 - Adjustable Wrench
 - 10' Tape Measure
 - Ratchet



WARNING

Reinstall the bolts that secure the Horizontal Sport Bars to the windshield with a torque of 17.0 ft. lbs. each. If you do not have a torque wrench, these bolts should be tested by a qualified mechanic using a torque wrench. Failure to tighten and test the torque of these bolts can result in personal injury or loss of life to the driver and occupants of the vehicle in the event of an accident.

Step Two

Wrangler/YJ: Use a #20 Torx to remove the outboard sun visor fasteners on both sides of the windshield frame. Remove the two #40 Torx head bolts that secure the horizontal sport bar to the windshield frame. Slide the Windshield Brackets between the windshield and the horizontal sport bar mounts.

Reinstall the Torx head bolts, starting each in the frame with your fingers. After the Torx head bolts are started by hand, tighten with your ratchet and Torx drive tool. Do not lay this tool aside until both bolts are completely tightened. If you tighten one of these bolts and the telephone rings - LET IT RING. NEVER LAY THIS TOOL ASIDE OR INTERRUPT THIS PROCEDURE. This procedure should be followed carefully on both sides of the vehicle.

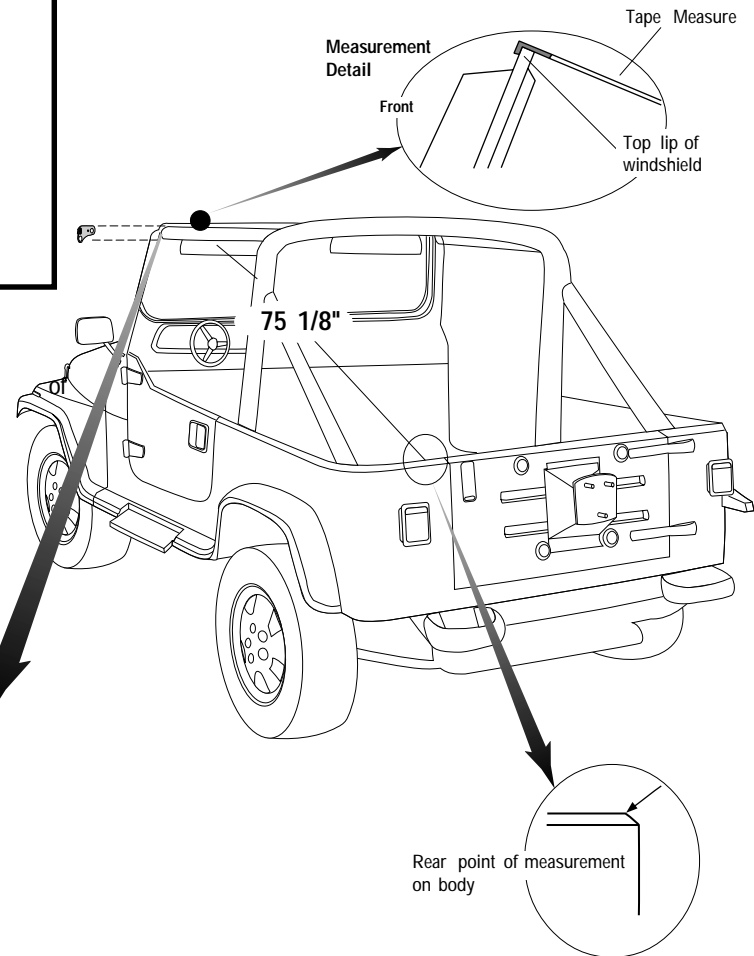
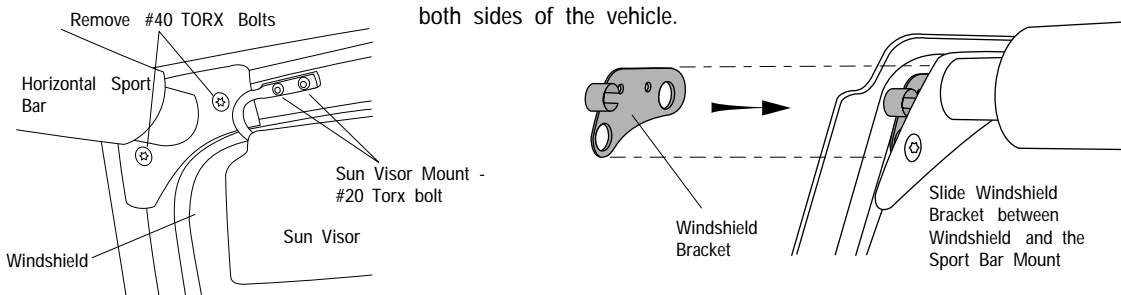

Step Three

If you have removed an old soft top and windshield retainer, install a Christmas Tree Fastener in each hole in the windshield frame.

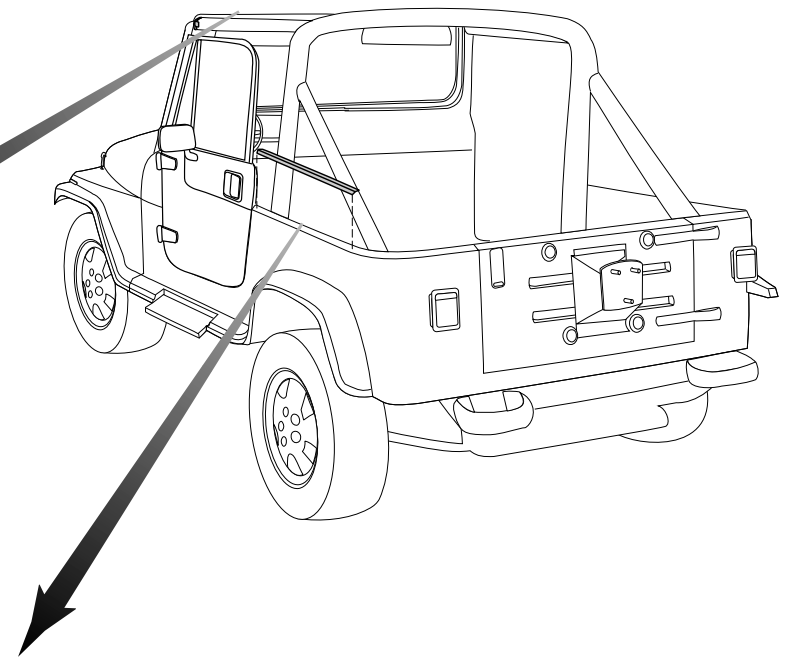
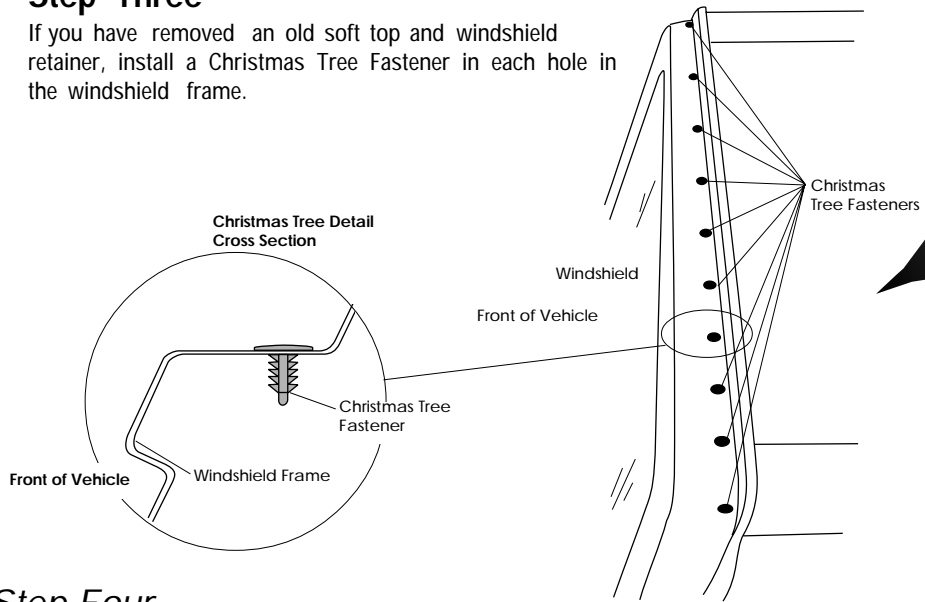

Step Four

Install the Left and Right Side Belt Rails on each side of the vehicle. Use the existing holes, four 5/16" TORX Bolts and four Tapping Plates on each side. Use a #35 TORX Socket to install the TORX Bolts.

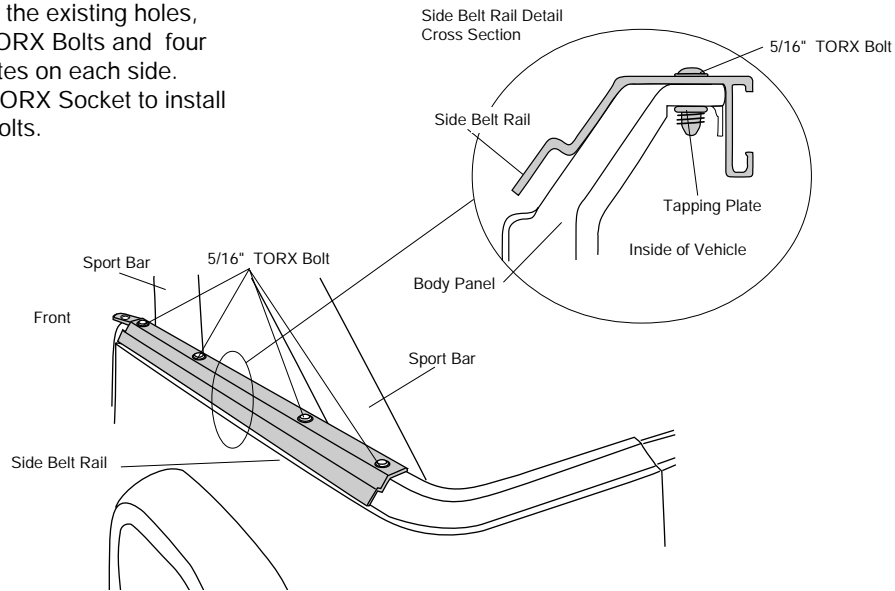



Caution

When drilling in the top edge of the vehicle body, check underneath for wiring for the rear lights. Pull the wiring out of the way before drilling.

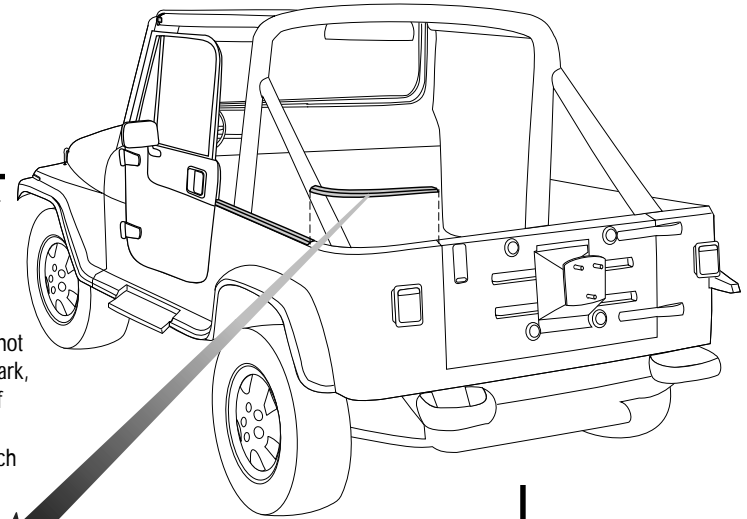

Step Five

Install the Left and Right Rear Corner Belt Rails on each side of the vehicle. Notice that the Corner Belt Rails do not butt-up against the Side Belt Rails installed in Step 3, this is normal. Use the Corner Belt Rails as templates to mark, center punch and drill two 3/8" holes in the top edge of the vehicle body. Some vehicles may already have some of these holes. Install the Corner Belt Rails with two 5/16" Phillips Head Bolts, two 5/16" Washers and two 5/16" Tapping Plates. At the location of the remaining hole in the Corner Belt Rail, next to the tailgate, mark, center punch and drill a 1/8" hole. Install a #8 x 1/2" Pan Head Screw. **Do not tighten the bolts yet.**

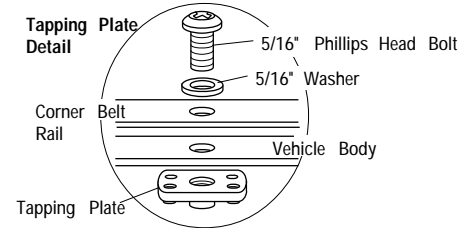
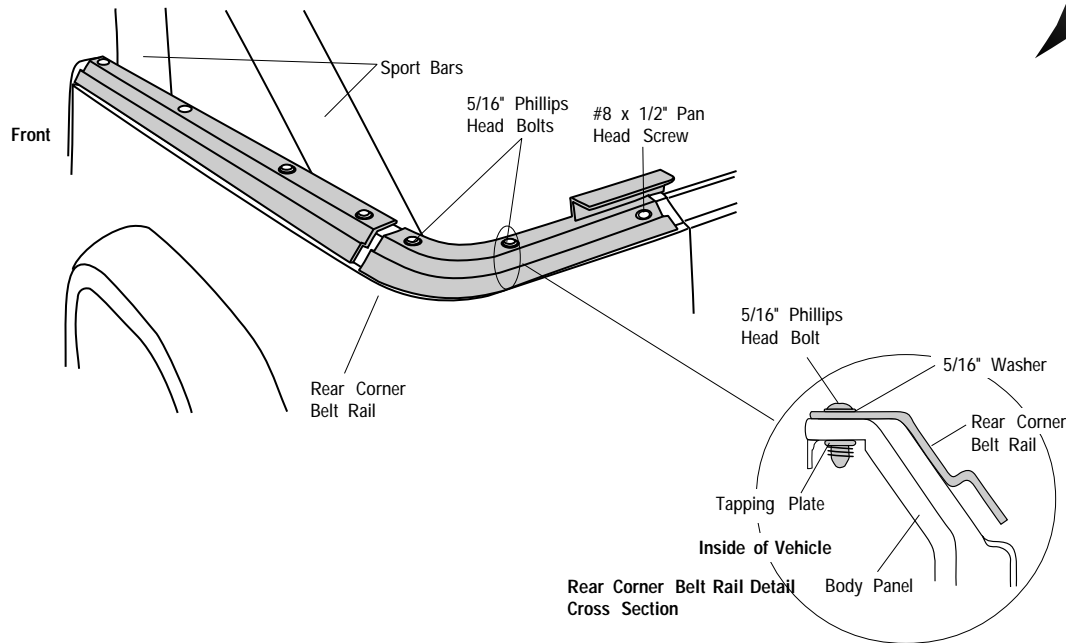

Note: There may be a small gap of +/- 1/4" between the Corner Belt Rails and the Side Belt Rails.

Step Six

Assemble the two halves of the support bow. Orient the two pieces to each other and lay them on the floor. Slide the pieces together, pushing down on the buttons.

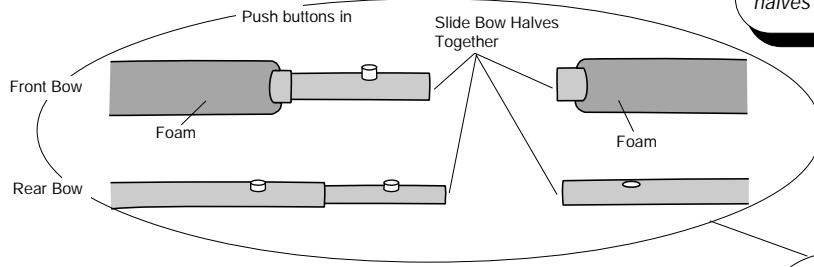

Note: It may be helpful to use a flat screwdriver to push buttons down while sliding bow halves together.

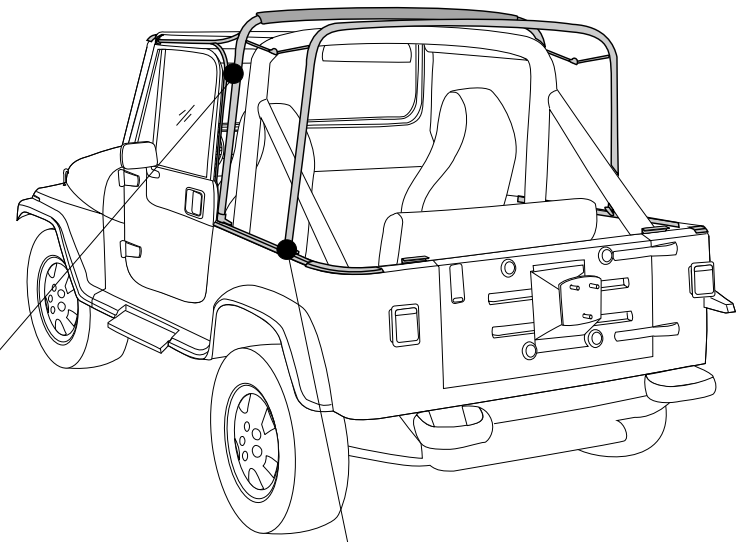
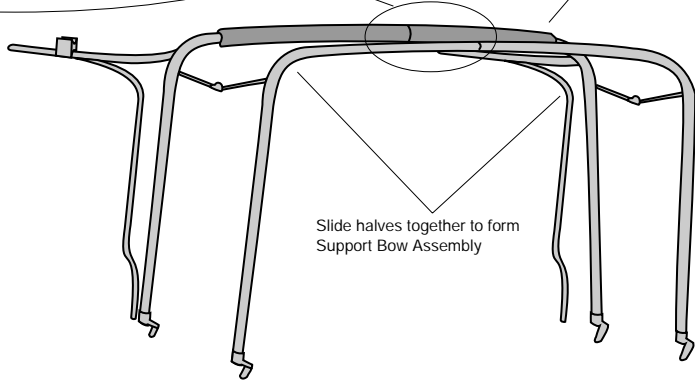

Note: It may be helpful to have two people to slide both sides of the bow assembly forward at the same time.

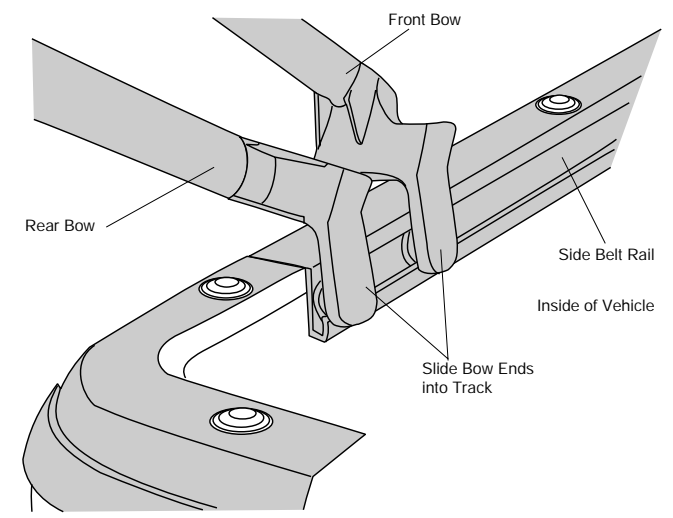

Step Seven

Slide the ends of the front and rear bows into the tracks in the Side Belt Rails on each side of the vehicle. Start from the rear of the vehicle and slide the bow assembly toward the front.



Step Eight

Place the bottom of the Vertical Rod on the Bow Assembly into the hole at the front of the Side Belt Rail.

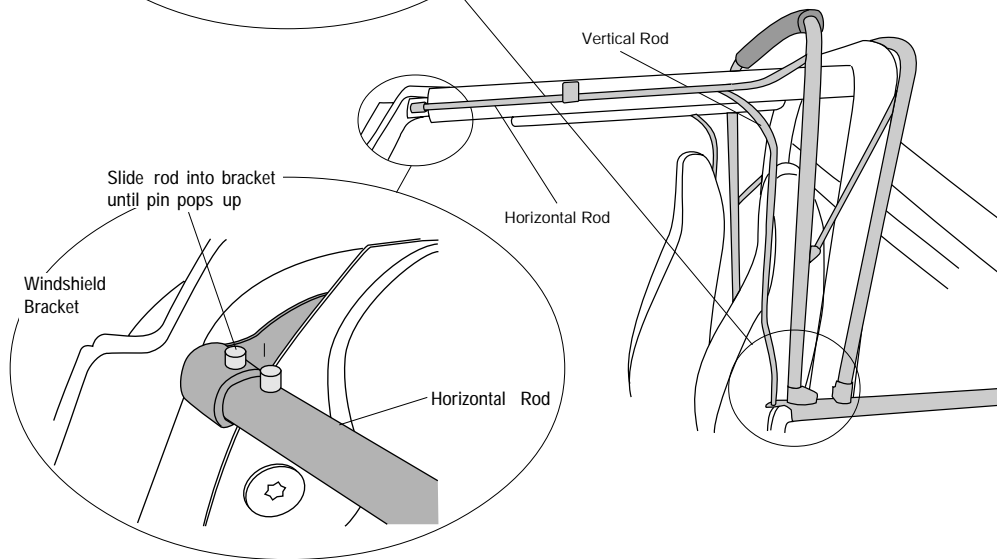
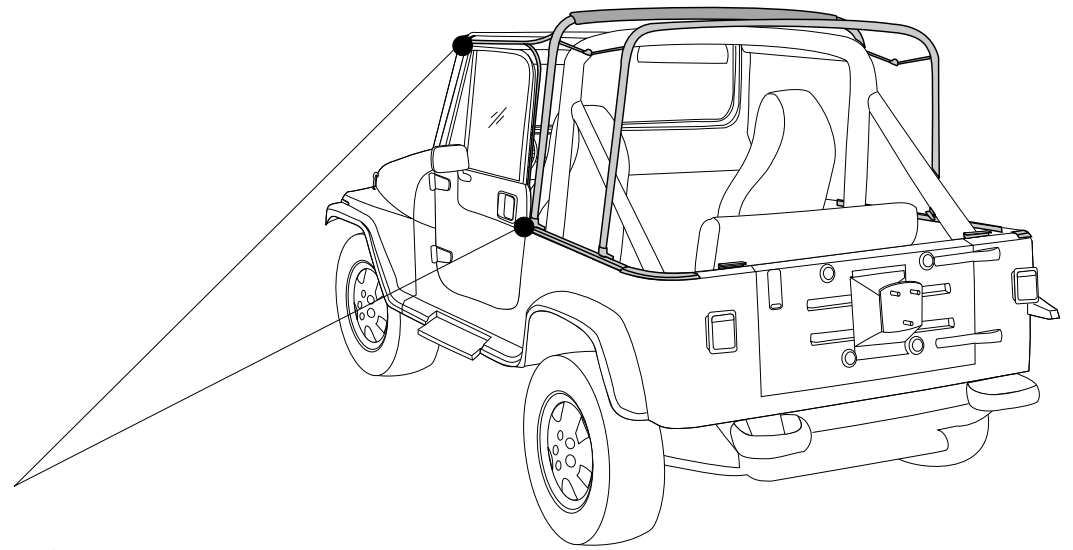
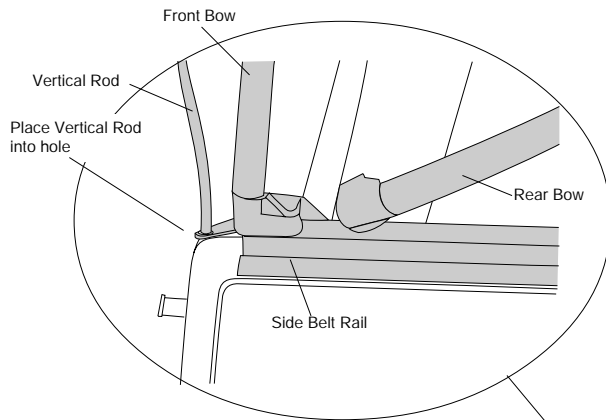

Step Nine

Slip the end of the Horizontal Rod into the tube on the Windshield Bracket until the spring button on the rod pops up through the Windshield Bracket.

Step Eleven

Orient the Windshield Header on the vehicle. Lay the header on top of the bows with the snap studs facing up. Place the legs of the header into the bracket above the door opening on each horizontal rod. Install the legs in the brackets with a #10-15/16 Bolt and Lock Nut on each side.

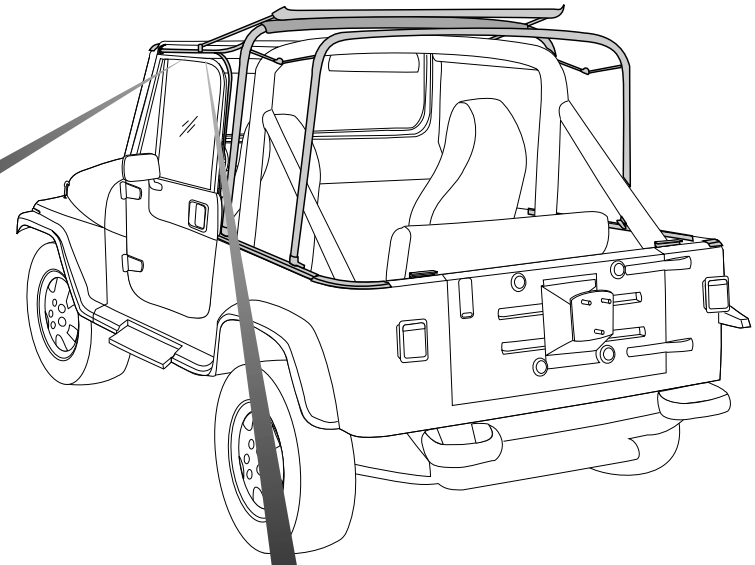
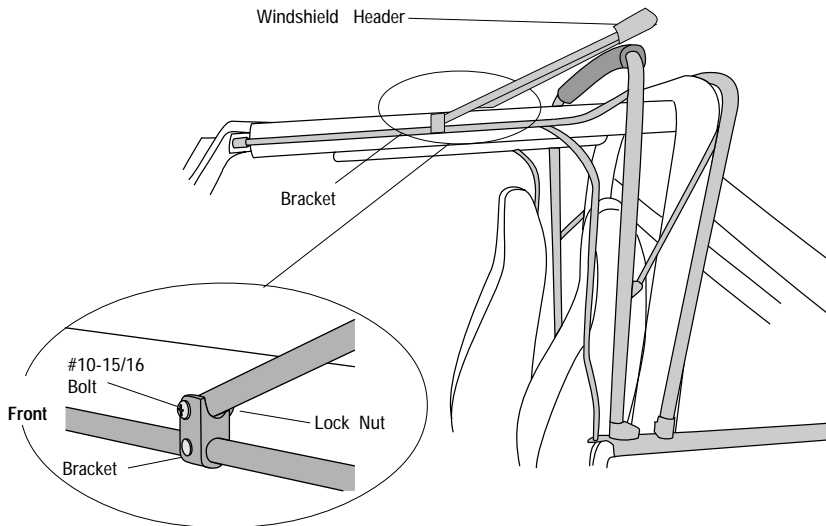

WARNING

Improper Latch installation will result in a poor fitting Header that could rattle or release under driving conditions.

Step Ten

Rotate the Windshield Header down onto the top of the windshield.

Locate the two Windshield Header Latches in the parts kit. Make sure that the latches are in the closed position. Hook each latch in the slots in the Windshield Header. Pull Header down flat on the windshield. Pop the lever out into the horizontal position and mark the location of the bottom hole in the latch. Remove the latch from the slot and spring the body of the latch out so that it is horizontal to the base and so that you can access the top mounting hole. Place the latch back in position with the bottom hole over the mark on the windshield and mark the location of the top hole. Remove the latch, center punch the marks and drill two 1/8" holes per latch in the windshield frame. Install each latch with two #8 x 5/8" Screws.

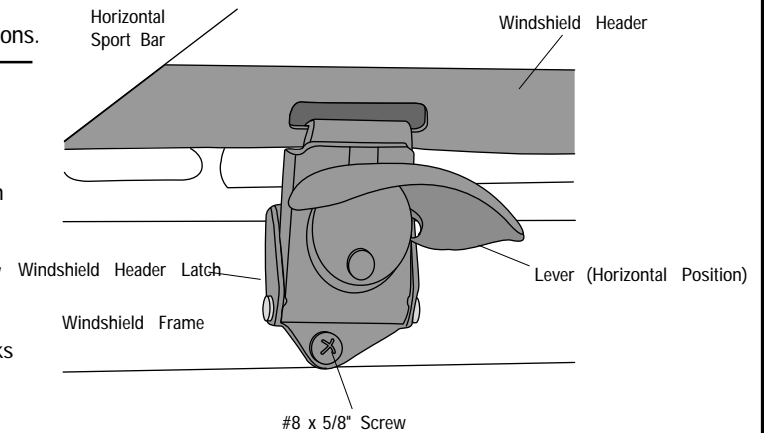

Step Twelve

Open the latches and raise the Windshield Header . Locate the rubber Windshield Header Trim in the parts kit. Slide the slotted edge of the trim over the front edge of the Windshield Header. Trim to fit.

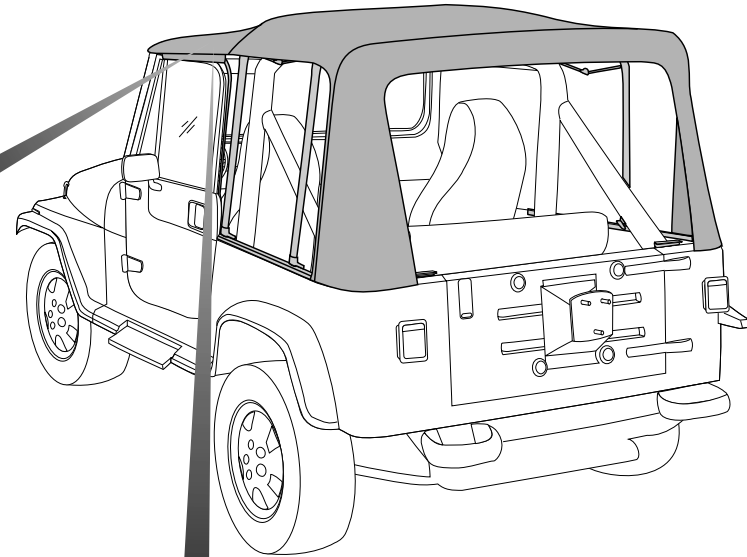
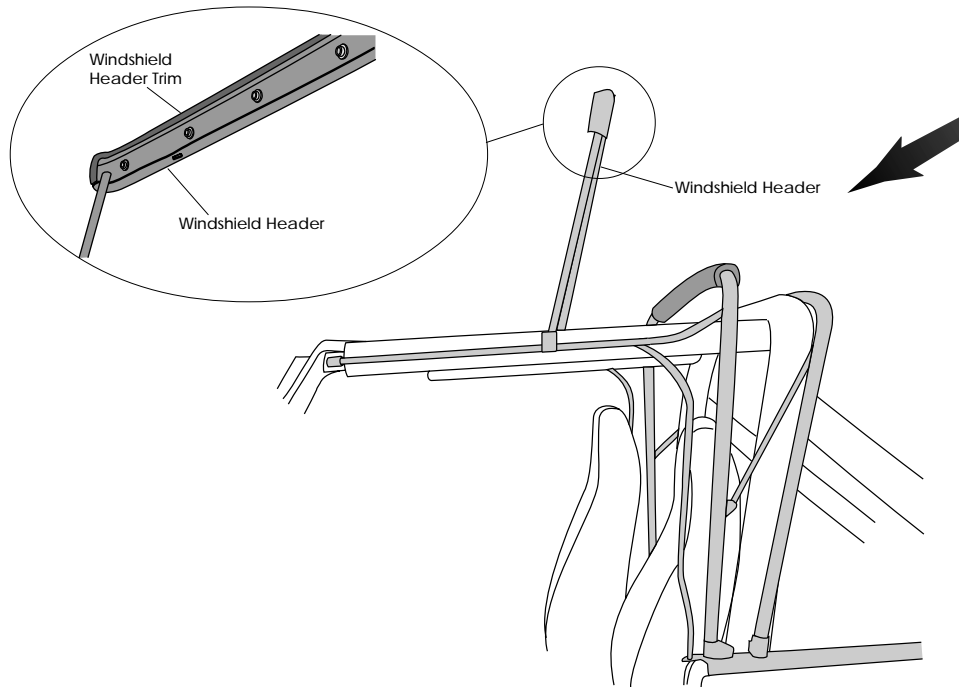

Step Thirteen

Locate the top and orient it on the vehicle. Drape the top over the bows and wrap the front edge of the fabric around the front edge of the Windshield Header. Snap the fabric to the header.

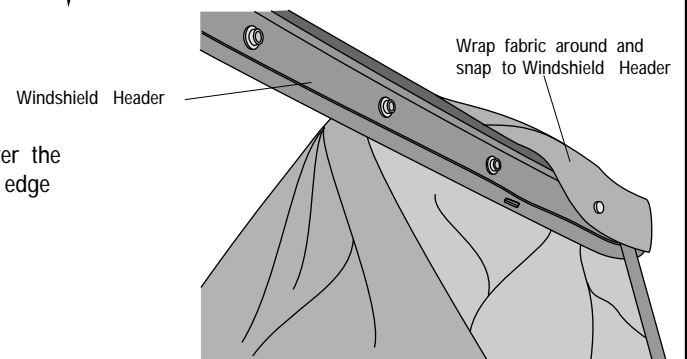

Step Fourteen

Locate the top and orient it on the vehicle. Snap it to bows.

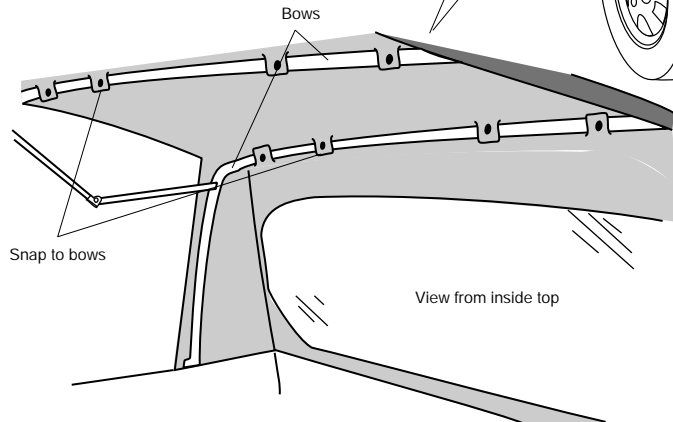
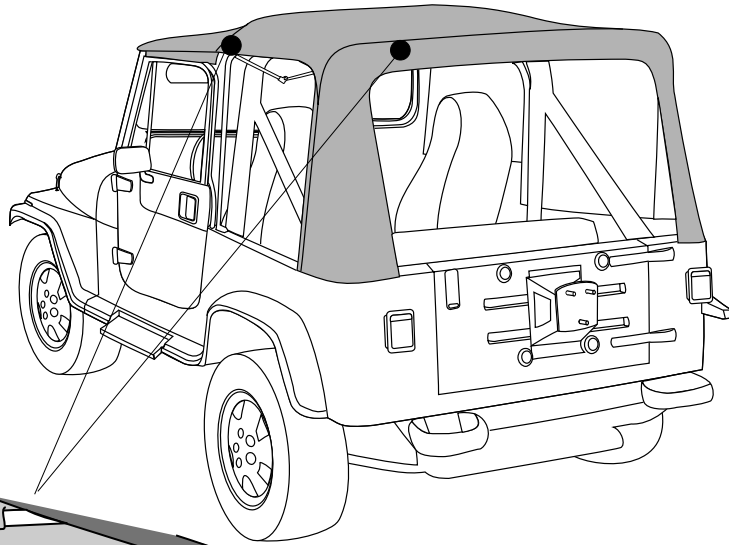

Step Fifteen

Push front support bow all the way forward.

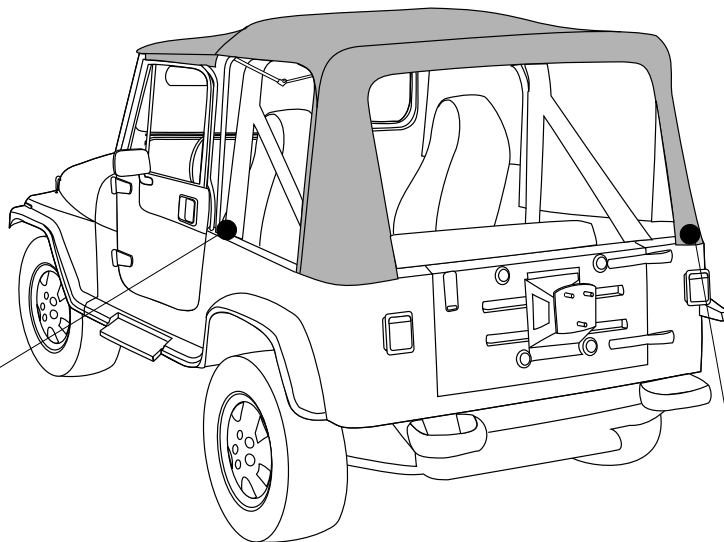
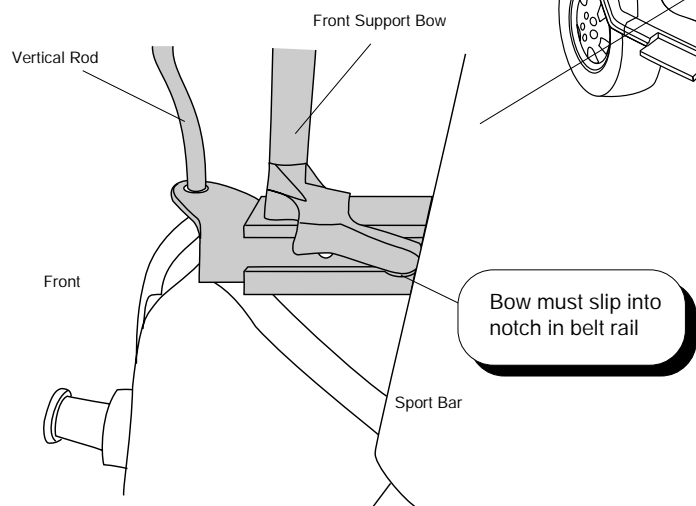

Step Sixteen

Insert rear corners of top into rear corner retainer.

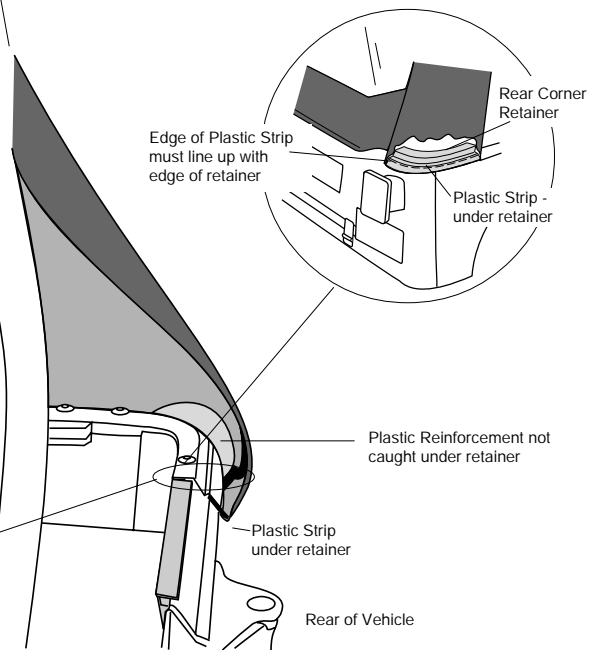
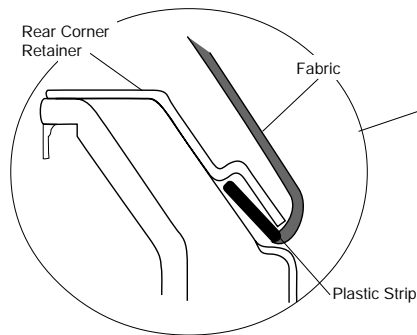

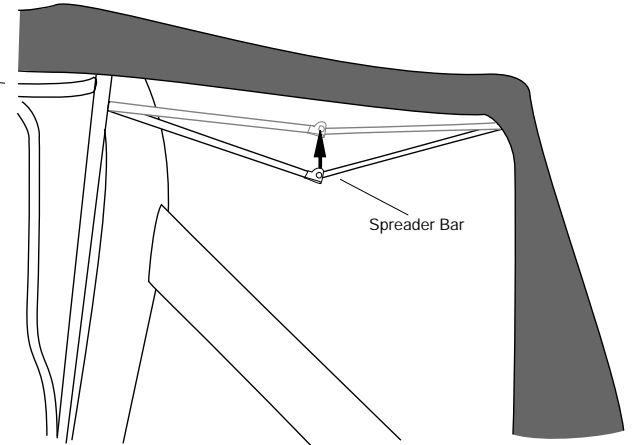
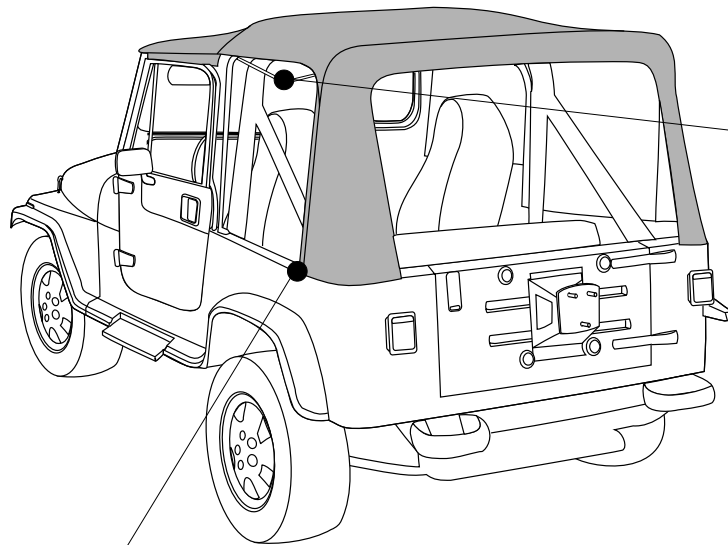

Step Seventeen

Pull the bottom of the rear support bow back until it snaps into the notch in the side rail.

Step Eighteen

Push in the two snap buttons on the spreader bar and raise the bar into position. Release the snap buttons to lock the bar in place.

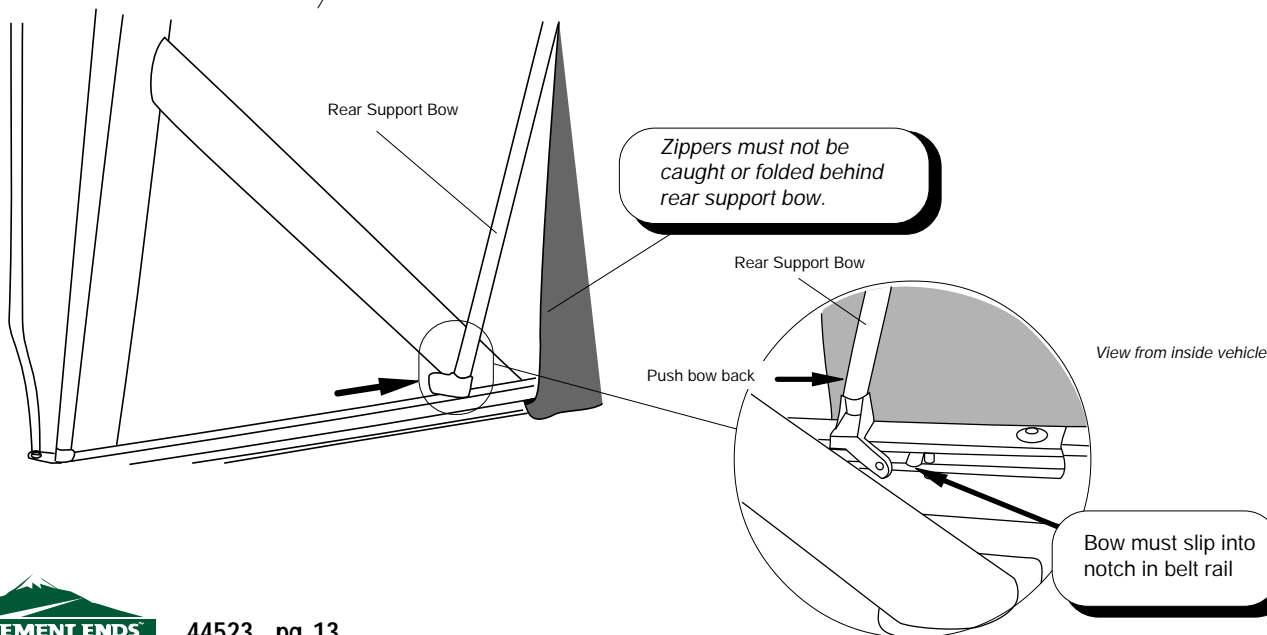

Step Nineteen

Start top and rear zippers on side curtain 2-3 inches.

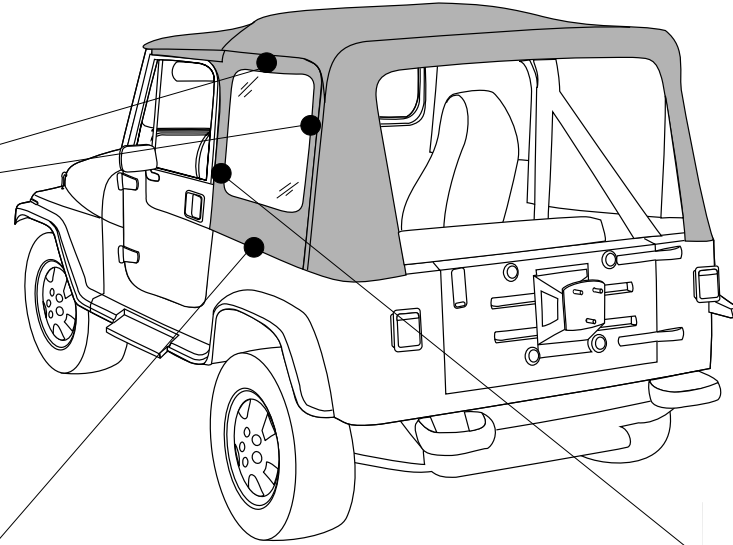
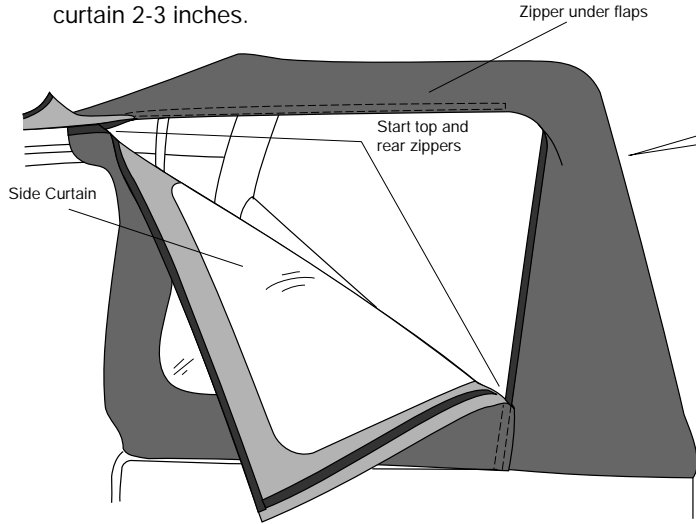

Step Twenty-one

Wrap fabric flap on the front of the side curtain around the Vertical Rod (not the front bow) and fasten the hook and loop strips to each other.

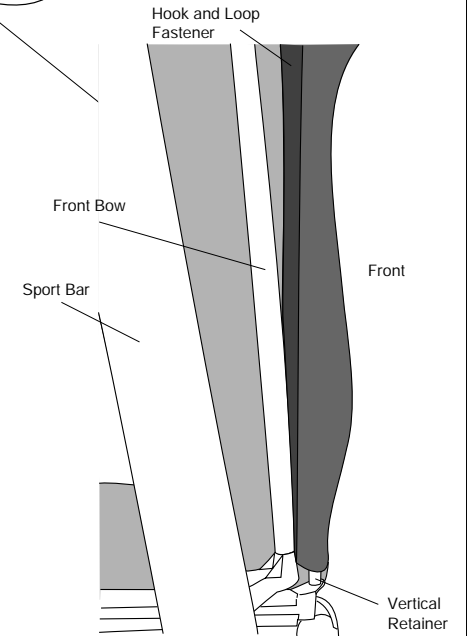

View from inside vehicle - Driver's Side

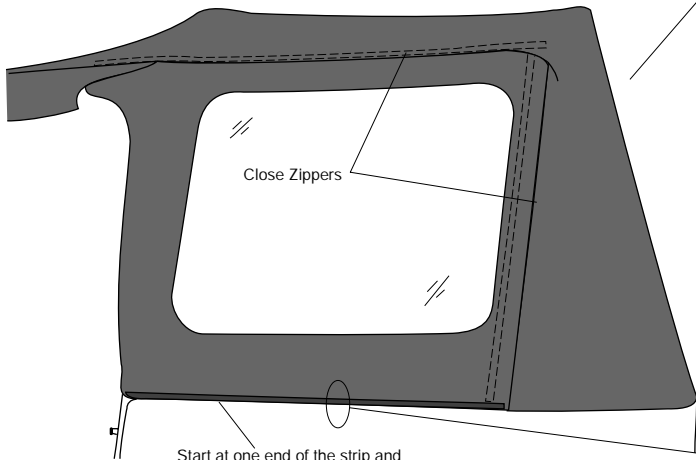

Step Twenty

Slip the plastic strip on the bottom of the side curtain into the side retainer. Close the top and rear zippers on the side curtain.

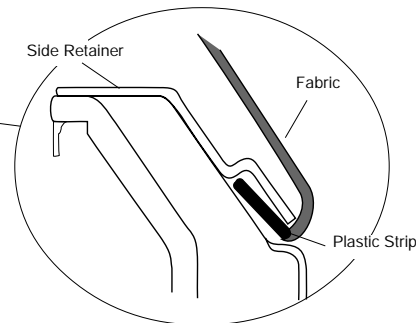

Step Twenty-two

Wrap the flap, sewn to the top above each door, around the Horizontal Rod and fasten the hook and loop strips to each other.

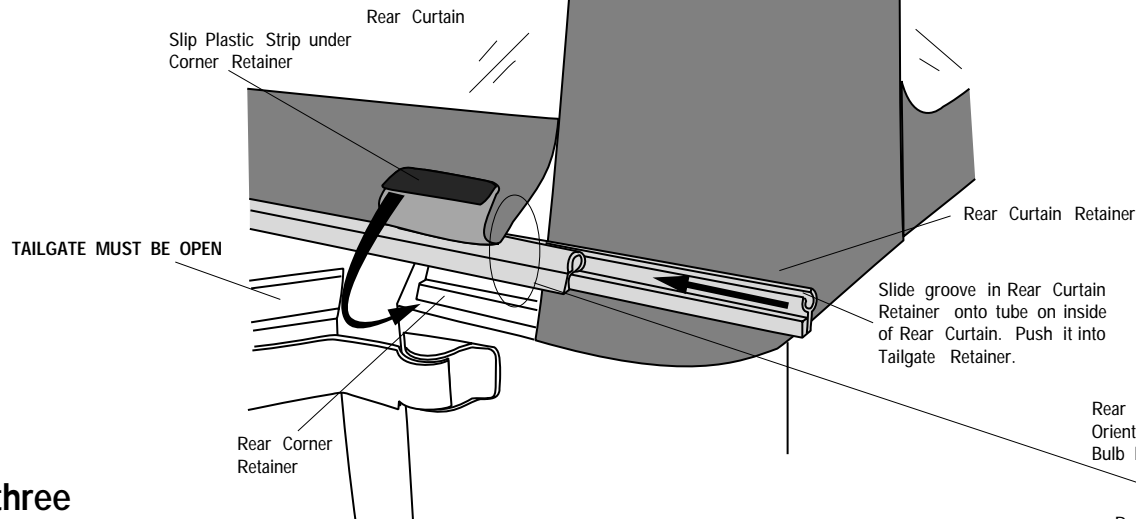
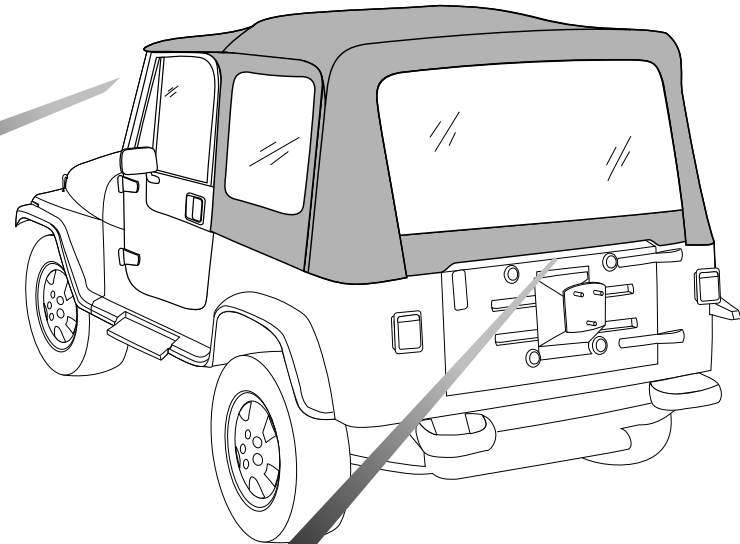
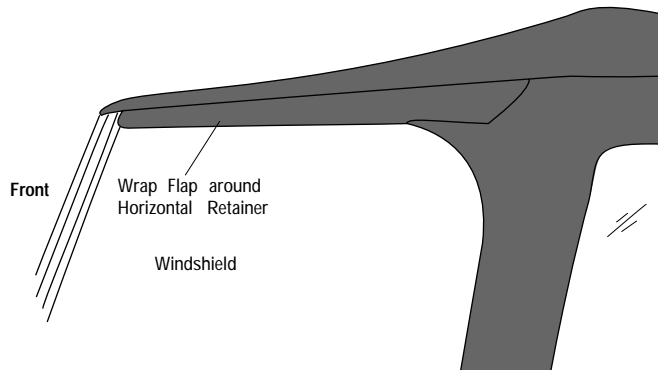

Slide groove in Rear Curtain Retainer onto tube on inside of Tailgate Retainer.

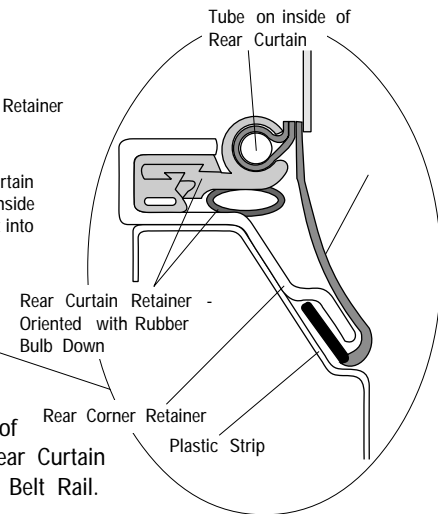

Step Twenty-three

Open the tailgate. Orient the Rear Curtain Retainer with the rubber bulb facing down, in order to form a seal with the top of the tailgate. Slide the groove in the Rear Curtain Retainer onto the tube inside the bottom of the Rear Curtain. Roll the Rear Curtain Retainer into the top of the Corner Belt Rail. Slip the plastic on the bottom of the corners under the bottom of the Corner Belt Rail. Close the rear curtain zipper.

Adjusting the Top



WARNING

When operating the vehicle without the Side Curtains, the Rear Curtain should be rolled up for proper ventilation.

Opening the Sun Roof

Release the Windshield Header Latches and fold the Windshield Retainer back so that it rests on the center bow and the sport bar.

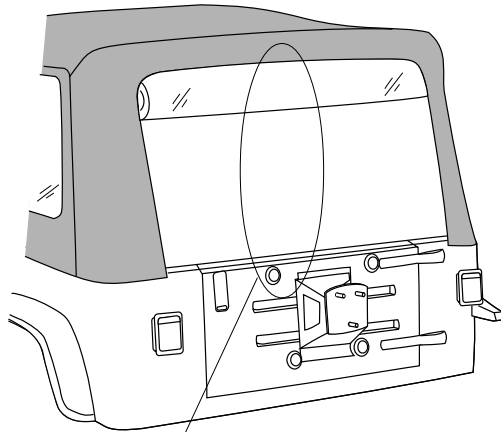

Side Curtains

To remove the Side Curtains. Unzip the rear and top zippers. Release the plastic strip from the retainer. Release the Hook and Loop Fasteners from around the Vertical Retainer.

Rear Curtain

To roll up the Rear Curtain, remove the Rear Curtain Retainer and start at the bottom, rolling it to the inside. Avoid wrinkles in the fabric and window. Secure it in place with the curtain straps inside of the top.

Detail of Rear Curtain

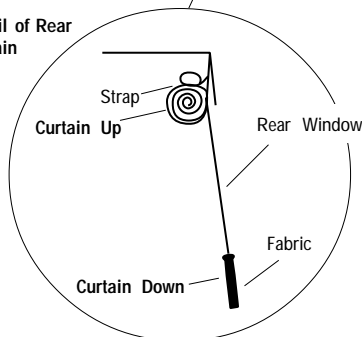

Side View

Removal of Soft Top for Open Air Driving

When operating the vehicle with the fabric top removed, it is very important that the supporting hardware system be disconnected from the windshield bracket and folded flat to the rear of the vehicle. Wrap the elastic straps around the bows and insert the plastic strip into the side belt rail. Never operate the vehicle with the fabric removed and the hardware in the fully erected position.

Care and Maintenance of your FlipTop

Your top is made of the finest materials available. To keep it looking new and for the maximum possible wear, it will need periodic cleaning and maintenance.

Washing: The top fabric should be washed often using soap, warm water and a soft bristle brush. Rinse with clear water to remove all traces of soap.

Windows: Keep windows clean to avoid scratching. DO NOT use a brush on the windows! Wash with a watersoaked cloth or sponge and a mild dishwashing detergent. NEVER WIPE THE WINDOWS WHEN THEY ARE DRY. Be careful when cleaning snow or frost from the vinyl windows since they are easily scratched and may crack at low temperatures. DO NOT roll the sides or rear window in cold weather. The windows become stiff and will crack.

Zippers: Keeping the zipper cleaned and lubricated with a silicone lubricant will help prevent damage and keep the zippers in a smooth working condition. If a zipper opens behind the slider, the slider may have been spread apart. This problem can usually be repaired by using an ordinary pair of pliers to bring the sides back into parallel. Return slider to the end of the zipper in the normal Open position. Squeeze lightly at first and test the zipper. If the zipper continues to remain open squeeze more firmly with the pliers and try the zipper again. Repeat this procedure until the zipper operates correctly.

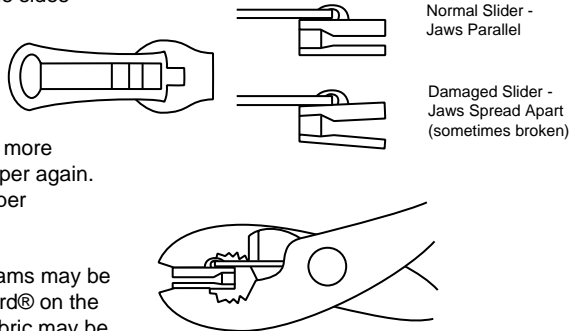

Water: Seeping through at the seams may be stopped by applying 3-M Scotchgard® on the inside of the seams. Rips in the fabric may be repaired with Bondex® iron on patches. Iron the patches to the Inside of the top, carefully following the Bondex® instructions.

Snaps: Keep snaps cleaned and lubricated with silicone to help prevent snaps from sticking to the studs. If a snap does become stuck to a stud, use a screwdriver and GENTLY pry apart to prevent permanent damage to the snap or the top fabric.

LIMITED WARRANTY

We warrant our product to be free from defects in material and workmanship, for the terms specified below, provided there has been normal use and proper maintenance. This warranty applies to the original purchaser only. All remedies under this warranty are limited to the repair or replacement of any item or items found by the factory to be defective within the time period specified.

If you have a warranty claim, first you must call our factory at the number below for instructions. You must retain proof of purchase and submit a copy with any items returned for warranty work. Upon completion of warranty work, if any, we will return the repaired or replaced item or items to you, freight prepaid. Damage to our products caused by accidents, fire, vandalism, negligence, misinstallation, misuse, Acts of God, or by defective parts not manufactured by us, is not covered under this warranty.

THE WARRANTY TIME PERIOD IS AS FOLLOWS: ALL "SOFT GOODS" MANUFACTURED BY OUR COMPANY (USING PRIMARILY VINYL, PLASTICS, AND/OR FOAM): ONE YEAR FROM DATE OF PURCHASE.

ANY IMPLIED WARRANTIES OF MERCHANTABILITY AND/OR FITNESS FOR A PARTICULAR PURPOSE CREATED HEREBY ARE LIMITED IN DURATION TO THE SAME DURATION AND SCOPE AS THE EXPRESS WRITTEN WARRANTY. OUR COMPANY SHALL NOT BE LIABLE FOR ANY INCIDENTAL OR CONSEQUENTIAL DAMAGE.

Some states do not allow limitations on how long an implied warranty lasts, or the exclusion or limitation of incidental or consequential damages, so the above limitations or exclusions may not apply to you.

This warranty gives you specific legal rights, and you may also have other rights which vary from state to state.

For further information or request for warranty work, please contact: Customer Service
877 638-9509