

**Contents:**

Lock Assembly  
Instructions  
Warranty Card

**Tools Required:**

Phillips Head Screw Driver

**Tech Support:**

Call 1-800-342-5911

For the latest instructions please  
visit [www.popandlock.net](http://www.popandlock.net)

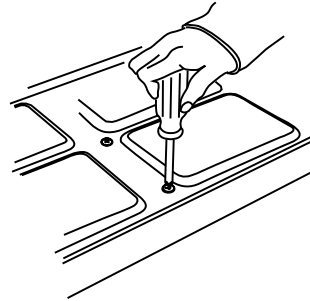

1.

Unscrew the 8 access panel screws and remove panel

Note: Bedliner panel may have to be removed.

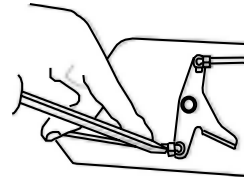

2.

Carefully unclip the plastic rod retainers off using a screw driver and remove rods from the scissor.

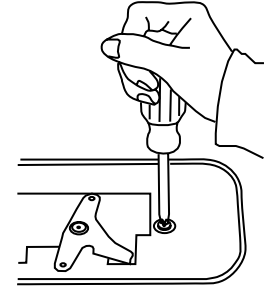

3.

Unscrew the two handle mounting screws and remove handle

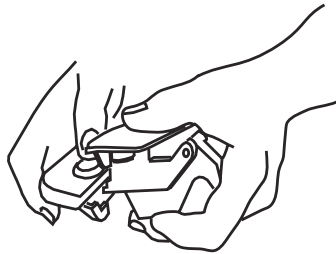

4.

Join the handle and the POP&LOCK together like a tongue and groove.

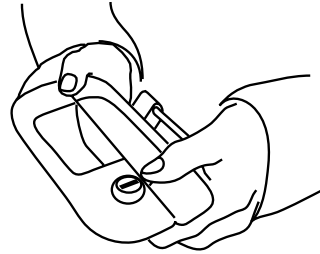

5.

Push the handle firmly down onto the POP&LOCK until they fit together to form a tight assembly.

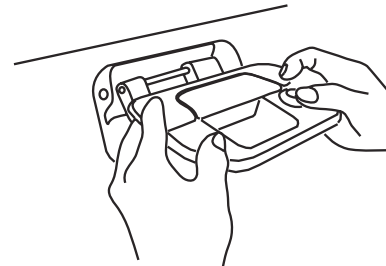

6.

Insert the handle and POP&Lock assembly into the tailgate.

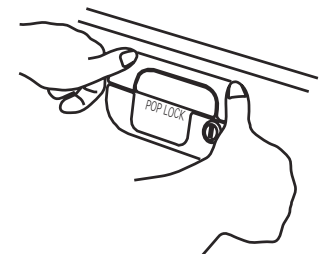

7.

Push the assembly down to align it with the mounting holes. Reassemble all components in the reverse order.

## LIMITED WARRANTY TERMS AND CONDITIONS

- (1) **Installation.** Pop & Lock™, LLC (and Pop & Lock™ Corporation) is not responsible for installing the Pop & Lock™ or for the harm suffered by any person as a result installing it.
- (2) **Warranties.**
- Customer acknowledges that it is unreasonable to believe that any device whatever will prevent a theft in the case of every attempt and that the most that can be expected from a so-called anti-theft or security device is that it will deter many thieves.
  - POP & LOCK™ LLC. (and Pop & Lock™ Corporation) MAKES, AND CUSTOMER RECEIVES, NO WARRANTY, EXPRESSED OR IMPLIED, EXCEPT THE WARRANTIES OF TITLE TO THE POP & LOCK™ AND THEIR MERCHANTABILITY, PARTICULARLY NO WARRANTY OF FITNESS FOR A PARTICULAR USE OR PURPOSE OR AGAINST INFRINGEMENT.**
  - As Customer's only remedy, Pop & Lock™, LLC (and Pop & Lock™ Corporation) will repair or replace, at its option and without charge, any lock that is defective in material or workmanship when received by Customer and is returned to Pop & Lock™ LLC (and Pop & Lock™ Corporation), FOB Pop & Lock™ Corporation's offices, within one (1) year after it's receipt by the Customer. Pop & Lock LLC will ship all replacement, or repaired, Locks to Customer, FOB Pop & Lock™'s shipping point.
  - Factory support is only available for Pop & Lock™ products purchased as **new** through an Authorized Pop & Lock™ dealer.  
**Please Note:** *Pop & Lock™ Products purchased on auction sites such as Ebay, Amazon and Craigslist, to name a few, will not be covered under factory warranty under any circumstance. Pop & Lock™, LLC (and Pop & Lock™ Corporation) is unable to verify whether products sold through Auction Sites are new, used, or refurbished, and as such, Pop & Lock, LLC (and Pop & Lock™ Corporation) is unable to warranty such purchases. Pop & Lock, LLC advises using extreme caution when buying through auction sites as you'll be doing so at your own risk.*
- (3) **No Liability.** Pop & Lock™ Corporation is not liable for any loss or damage claimed by Customer or any third person to have been suffered or incurred as a result or, or related to, the Locks purchased under this Agreement, regardless of the circumstances or form of action, except any bodily injury or death for which Pop & Lock™ is liable under products-liability law. Without limiting the generality of the foregoing, in no event will Pop & Lock™ LLC be liable to Customer for any indirect, special, or consequential damages, regardless of the circumstances or the cause of action, particularly not for the value of a vehicle, or any other money damages in the event that a tailgate is stolen either notwithstanding the use of a Pop & Lock™ or when it has been returned for repair or replacement.

## END OF TERMS AND CONDITIONS

Please Mail Completed Warranty Form (below) In Self Addressed Envelope To:

**POP & LOCK LLC 1271 CONTRACT DRIVE GREEN BAY, WI USA 54304**

Additional Install Instructions and answers to technical questions can be found on our website at [www.popnlock.net](http://www.popnlock.net) or by calling

**Technical Support 1-800-342-5911**

**Monday – Friday 8am to 5pm CST**



## POP & LOCK™ LIMITED WARRANTY FORM

Please complete and mail this form to record your warranty with the manufacturer.

NAME \_\_\_\_\_

ADDRESS \_\_\_\_\_

CITY \_\_\_\_\_

STATE \_\_\_\_\_ ZIP \_\_\_\_\_

TELEPHONE # \_\_\_\_\_

EMAIL ADDRESS \_\_\_\_\_

POP & LOCK™ MODEL \_\_\_\_\_

VEHICLE YEAR \_\_\_\_\_

VEHICLE MAKE/MODEL \_\_\_\_\_

REASON FOR RETURN (continue on other side):