

## Parts Included

Power Lock	Relay Wiring Cable
Short Wiring Cable	Blue Connector Taps
Long Wiring Cable	Cable Ties

**DODGE RAM 1500**

**2009 & Up**

New Body Style

**DODGE RAM 2500/3500** **2009/10 & Up**

New Body Style

## Tools Required

#10 Torx Driver  
10 MM socket  
Ratchet  
Ratchet Extension  
Pliers

For the latest instructions please  
visit [www.popandlock.net](http://www.popandlock.net)

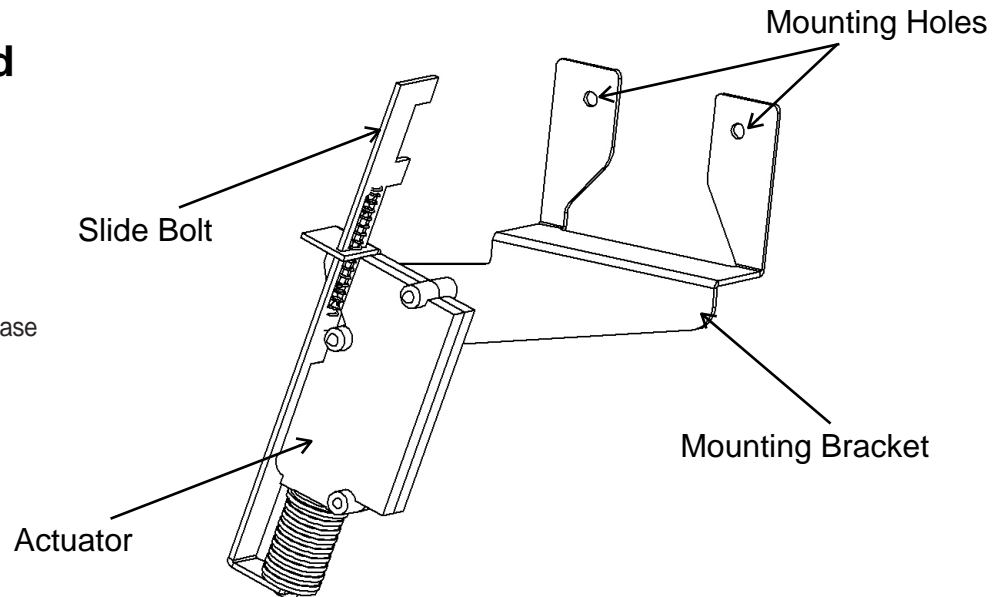

Diagram 1 - Power Lock Details

1. Open the tailgate and if applicable, remove the tailgate bed-liner.
2. Using a #10 Torx driver, remove the 8 screws holding the access panel.
3. Remove the access panel and set aside.
4. Remove the two 8mm nuts from the inside of the tailgate holding the handle assembly. The latch rods do not have to be removed from the handle assembly.
5. Slide the PL8350 POWER LOCK through one of the access openings on the passenger's side of the tailgate and slip the bracket over the two studs of the handle assembly.
6. Make sure that the Slide Bolt opening is centered over the OEM plastic locking arm. See Diagram 2 for details.
7. Replace the two 8mm nuts over the studs and tighten while ensuring proper function of the POWER LOCK by manually moving the Slide Bolt up and down.
8. Using the OEM ignition key, lock and unlock the manual lock to ensure that the POWER LOCK is not interfering with the manual locking mechanism.
9. Tape the connector end of the short wiring harness to a coat hanger or electrical fish tape. Slip it through the top access hole down to the bottom of the tailgate and through the drain hole.
10. Connect the short wiring harness to the POWER LOCK. Wherever possible, use cable ties to fasten the harness preventing it from moving.
11. Connect the other end of the short wiring harness to the Long wiring harness and locate the connector so that it is accessible for tailgate removal. Make sure that the tailgate cannot pinch the harness when opened or closed.
12. Run the long wiring harness underneath the truck driver's side, following the OEM body harness underneath the truck driver's side, following the OEM body harness to the firewall, into the fender well and to the engine compartment. Make sure to use enough cable ties to prevent the wiring

**POP & LOCK®**

- harness from moving.
13. Mount the Relay kit on a suitable location near the battery.
  14. Attach the long wiring harness to the relay harness by attaching the green to green and blue to brown wires.
  15. Run the **purple** and **gray** wire bundle through the firewall of the truck. Please try to follow the OEM wiring routes if possible.
  16. Locate the **Tan** with **White stripe** and **Tan** with **Green stripe** wires under the dash, near the brake pedal in the larger wiring harness.
  17. Install a blue connector tap on each wire and slide the purple and the gray connectors over the blue connector taps.
  18. Attach the relay harness to the battery by connecting the fused lead (red) to the positive terminal and the black lead to the negative terminal.
  19. Test the POWER LOCK by locking and unlocking the power door locks. If the POWER LOCK is in reversed order to the vehicle power lock, then reverse the purple and gray wires under the dash.
  20. Re-install the access panel on the tailgate and the tailgate bed-liner if applicable.

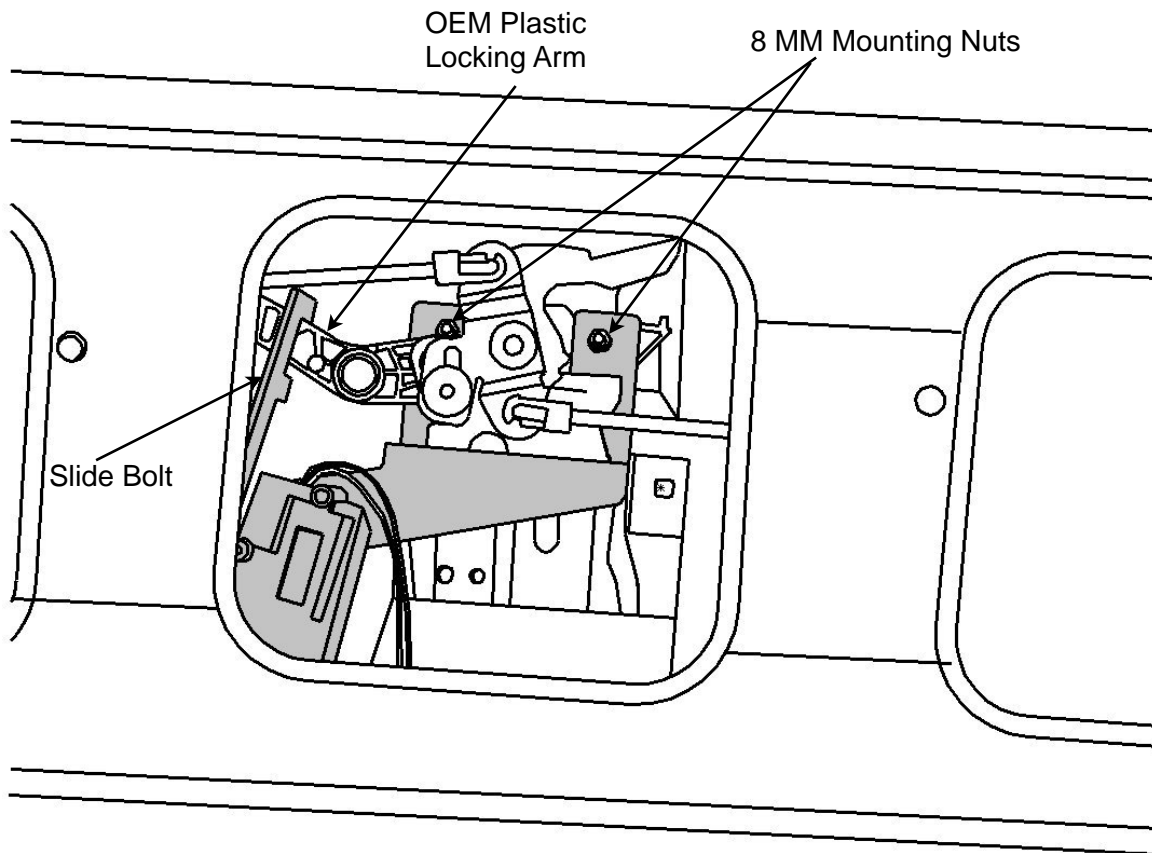

Diagram 2 - Assembled View

## LIMITED WARRANTY TERMS AND CONDITIONS

- (1) **Installation.** Pop & Lock™, LLC (and Pop & Lock™ Corporation) is not responsible for installing the Pop & Lock™ or for the harm suffered by any person as a result installing it.
- (2) **Warranties.**
- Customer acknowledges that it is unreasonable to believe that any device whatever will prevent a theft in the case of every attempt and that the most that can be expected from a so-called anti-theft or security device is that it will deter many thieves.
  - POP & LOCK™ LLC. (and Pop & Lock™ Corporation) MAKES, AND CUSTOMER RECEIVES, NO WARRANTY, EXPRESSED OR IMPLIED, EXCEPT THE WARRANTIES OF TITLE TO THE POP & LOCK™ AND THEIR MERCHANTABILITY, PARTICULARLY NO WARRANTY OF FITNESS FOR A PARTICULAR USE OR PURPOSE OR AGAINST INFRINGEMENT.**
  - As Customer's only remedy, Pop & Lock™, LLC (and Pop & Lock™ Corporation) will repair or replace, at its option and without charge, any lock that is defective in material or workmanship when received by Customer and is returned to Pop & Lock™ LLC (and Pop & Lock™ Corporation), FOB Pop & Lock™ Corporation's offices, within one (1) year after it's receipt by the Customer. Pop & Lock LLC will ship all replacement, or repaired, Locks to Customer, FOB Pop & Lock™'s shipping point.
  - Factory support is only available for Pop & Lock™ products purchased as new through an Authorized Pop & Lock™ dealer.  
***Please Note: Pop & Lock™ Products purchased on auction sites such as Ebay, Amazon and Craigslist, to name a few, will not be covered under factory warranty under any circumstance. Pop & Lock™, LLC (and Pop & Lock™ Corporation) is unable to verify whether products sold through Auction Sites are new, used, or refurbished, and as such, Pop & Lock, LLC (and Pop & Lock™ Corporation) is unable to warranty such purchases. Pop & Lock, LLC advises using extreme caution when buying through auction sites as you'll be doing so at your own risk.***
- (3) **No Liability.** Pop & Lock™ Corporation is not liable for any loss or damage claimed by Customer or any third person to have been suffered or incurred as a result or, or related to, the Locks purchased under this Agreement, regardless of the circumstances or form of action, except any bodily injury or death for which Pop & Lock™ is liable under products-liability law. Without limiting the generality of the foregoing, in no event will Pop & Lock™ LLC be liable to Customer for any indirect, special, or consequential damages, regardless of the circumstances or the cause of action, particularly not for the value of a vehicle, or any other money damages in the event that a tailgate is stolen either notwithstanding the use of a Pop & Lock™ or when it has been returned for repair or replacement.

## END OF TERMS AND CONDITIONS

Please Mail Completed Warranty Form (below) In Self Addressed Envelope To:

**POP & LOCK LLC 1271 CONTRACT DRIVE GREEN BAY, WI USA 54304**

Additional Install Instructions and answers to technical questions can be found on our website at [www.popnlock.net](http://www.popnlock.net) or by calling

**Technical Support 1-800-342-5911**

**Monday – Friday 8am to 5pm CST**



## POP & LOCK™ LIMITED WARRANTY FORM

Please complete and mail this form to record your warranty with the manufacturer.

NAME \_\_\_\_\_

ADDRESS \_\_\_\_\_

CITY \_\_\_\_\_

STATE \_\_\_\_\_ ZIP \_\_\_\_\_

TELEPHONE # \_\_\_\_\_

EMAIL ADDRESS \_\_\_\_\_

POP & LOCK™ MODEL \_\_\_\_\_

VEHICLE YEAR \_\_\_\_\_

VEHICLE MAKE/MODEL \_\_\_\_\_

REASON FOR RETURN (continue on other side):