

Assembly Diagram  
Provided For  
Reference Use

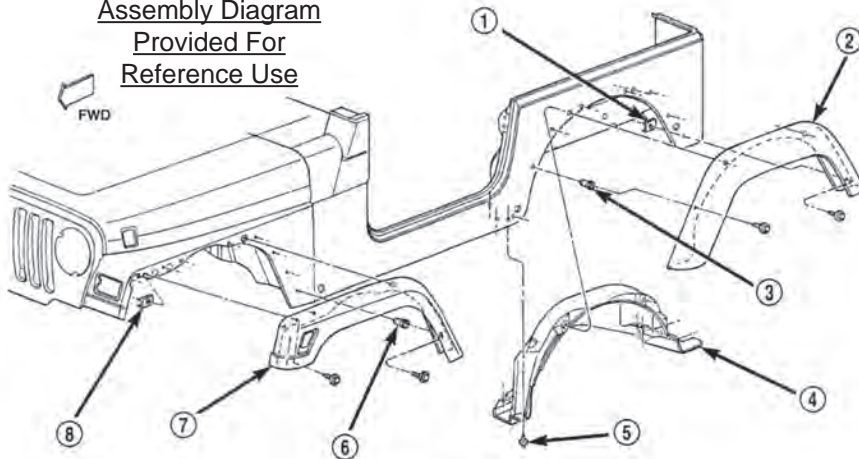

Fig. 7 FENDER FLARES

1 - U-NUT  
2 - FENDER FLARE  
3 - NUTSERT  
4 - SPLASH SHIELD

5 - RIVET  
6 - NUTSERT  
7 - FENDER FLARE  
8 - U-NUT

*\*HARDWARE NOTE: This kit includes complete brand new hardware (enough for installation on a completely new fender if necessary). We recommend replacing your old hardware with the supplied new hardware. When removing the old hardware, arrange the hardware in order of removal, from front to rear of the vehicle. Compare each old hardware item with the new hardware items, replacing them one at a time until all hardware has been replaced. Depending on the condition of your fasteners, you may have unused new hardware, which is acceptable. Discard the old hardware and store the unused new hardware for future use.*

**IMPORTANT!** Replace only ONE fender flare at a time.

## Front Fender Flare Installation:

**Step 1.** Reach inside the front edge of the front fender flare and locate the turn signal wiring harness. Follow the harness to the turn signal assembly. Using a twisting motion, remove the bulb assembly from the turn signal housing.



**Step 2.** Remove the inner fender-to-flare hex-headed washer screws located along the inner lip of the stock fender flare. The numbers 1 through 7 screws are held by rectangular black plastic retainers. To prevent the retainers from spinning in place, use a pair of pliers to grip the retainer while simultaneously turning the screw. The numbers 8, 9 and 10 screws are retained by body mounted riv-nuts and require no special tools for removal. Remove the screws from front to back of the vehicle in order. Place the screws on a flat surface (in order), replace hardware as necessary.\*



**Step 3.** Supporting the flare with two hands, pull the flare directly away from the body.

**Step 4.** Place the stock fender flare on a flat surface with the outside edge facing down. Remove the stock turn signal assembly by removing the single retainer nut. The turn signal assembly will then be easily removed from the outside of the fender flare.



**Step 5.** If so desired, now is a good time to clean the fender area which is covered by the fender flare.



**Step 6.** Place the new fender flare on a flat surface with the outside edge facing down. Transfer the turn signal assembly to the new fender flare, remembering to install the retainer nut to retain the turn signal housing.

**Step 7.** Take the new fender flare and align it to the fender using the existing flare and fender screw holes. Starting at the front of the vehicle, begin loosely installing the screws into the fender.



**Step 8.** Once the screws have all been installed, you may adjust the flare position for proper fender alignment. Once you are satisfied with the flare location, begin tightening the screws in order from the front to the rear of the vehicle. Tighten the screw snugly, taking care to not over-tighten.  
*NOTE: Due to variances in fenders and manufacturing processes, your new fender flares may or may not have locator pins, this is to allow for maximum adjustability for alignment.*

**Step 9.** Repeat for opposite side front fender. Installation is now complete for the front flares.

### Front Fender Flare Extension Installation:

**Step 1.** Remove the three (3) body-to-flare extension hex-headed washer screws located along inside of the extension. Place the screws on a flat surface (in order), replace hardware as necessary.\*

**Step 2.** Take the new flare extension and align it to the body using the existing flare and body mount screw holes. Starting at the front of the vehicle, begin loosely installing the screws into the body. Adjust the front-to-rear location until it is just touching the fender flair (some gap may occur across the width of the extension, this is normal). Starting at the front of the vehicle tighten the screw snugly, taking care to not over-tighten.

**Step 3.** Repeat for opposite side flare extension. Installation is now complete for the front fender flare extensions.

### Rear Fender Flare Installation:

**NOTE:** For ease of installation, we recommend removing the rear wheel well liner for easy access to the fender flare hardware. The wheel well liner is held in place by four (4) push-in black plastic fasteners located in the areas in front and rear of the wheel well (facing downward). Once these fasteners have been removed using the appropriate tool, it is now possible to remove the wheel well liner, starting at either the front or rear of the liner and working the liner out from the wheel well area.



**Step 1.** Remove the inner fender-to-flare hex-headed washer screws located along the inner lip of the stock fender flare. Work from the front of the vehicle towards the back. The numbers 1, 2, and 8 screws are retained by body mounted riv-nuts and require no special tools for removal. The numbers 3, 4, 5, 6, and 7 screws are held by rectangular black plastic retainers. To prevent the retainers from spinning in place, use a pair of pliers to grip the retainer while simultaneously turning the screw. Place the screws on a flat surface (in order), replace hardware as necessary.\*



**Step 2.** Supporting the flare with two hands, pull the flare directly away from the body.



**Step 3.** If so desired, now is a good time to clean the fender area which is covered by the fender flare.



**Step 4.** Take the new fender flare and align it to the fender using the existing flare and fender screw holes (do not worry about the inside flare lip, as it will self-align upon tightening of the hardware). Starting at the front of the vehicle, begin loosely installing the screws into the fender. Once all the screw have been installed, starting at the front of the vehicle tighten the screw snugly, taking care to not over-tighten. *NOTE: Due to variances in bodies and manufacturing processes, your new fender flares may or may not have locator pins, this is to allow for maximum adjustability for alignment.*



**Step 5.** Re-install the wheel well liner, working from the front of the wheel well to the rear, tucking the wheel well liner in along the way.

**Step 6.** Repeat for opposite side rear fender. Installation is now complete for the rear flares.

### LIMITED 90 DAY WARRANTY Applies to Rugged Ridge - Outland Automotive by Omix-Ada Inc. Products

Rugged Ridge - Outland Automotive and OMIX - ADA (the company) warrants to the original purchaser of this product that should the product or any part thereof, under normal use and conditions, be proven defective in material or workmanship within 90 DAYS from the date of original purchase, such defect(s) will be repaired or replaced or credited at the Company's sole option.

To obtain repair or replacement within the terms of this Warranty, the product is to be delivered with proof of warranty coverage (e.g. Dated bill of sale), specification of defect(s) to the place of purchase or, with prior approval from the Company (Return Authorization Number is required), freight pre-paid to the Company address listed below.

This warranty does not apply to any product or part thereof which, in the opinion of the Company, has suffered or been damaged through alteration, improper installation, mishandling, misuse, neglect, accident or by acts of nature. THE EXTENT OF THE COMPANY'S LIABILITY UNDER THIS WARRANTY IS LIMITED TO THE REPAIR OR REPLACEMENT PROVIDED ABOVE AND, IN NO EVENT, SHALL THE COMPANY'S LIABILITY EXCEED THE PURCHASE PRICE PAID BY PURCHASER FOR THE PRODUCT.

This Warranty is in lieu of all express warranties or liabilities. ANY IMPLIED WARRANTIES, INCLUDING ANY IMPLIED WARRANTY OF MERCHANTABILITY, SHALL BE LIMITED TO THE DURATION OF THIS WRITTEN WARRANTY. ANY ACTION FOR BREACH OF ANY WARRANTY HEREUNDER INCLUDING ANY IMPLIED WARRANTY OF MERCHANTABILITY MUST BE BROUGHT WITHIN THE PERIOD OF 90 DAYS FROM DATE OF ORIGINAL PURCHASE.

IN NO CASE SHALL THE COMPANY BE LIABLE FOR ANY CONSEQUENTIAL OR INCIDENTAL DAMAGES FOR BREACH OF THIS OR ANY OTHER WARRANTY, EXPRESS OR IMPLIED, WHATSOEVER. No person or representative is authorized to assume for the Company any liability other than expressed herein in connection with the sale of this product.

Some States do not allow limitations on how long an implied warranty lasts or the exclusion or limitation of incidental or consequential damage, so the above limitations may not apply to you. This warranty gives you specific legal rights and you may also have other rights, which vary from state to state.

Omix-Ada Inc.  
460 Horizon Dr. Suite 400  
Suwanee, Georgia 30024