



## Installation Instructions

### High Endurance Tube Steps with Pads

**Part No. 316/3166 02-08 Dodge Ram Quad Cab Pick Up 4 Dr.**  
**Part#:14316\16316 02-08 Dodge Ram 2 Door Std Cab**

#### Parts List:

2-Front Mount Brackets (short)	2-Rear Mount Brackets (long)	2-4.75" Threaded Studs (Rear)
2- 7" Threaded Studs (Front)	4-12mm Tube Bolts	4-12mm x 110mm Body Bolts
6-3/8" Serrated Nuts	4-12mm ID Flat Washers (large)	8-12mm Lock Washers
4-3/4" Rubber Bushings	6-5/16" Nuts	2-10mm ID Flat Washers
4-12mm ID Flat Washers (small for tube bolts)		

#### Installation:

- 1) Mount Front Flex Compensator to Front Mounting bracket. (See illustration page 2) Locate 7" double threaded stud and install one 5/16" nut on each end and thread down to end of threads. On short threaded end of stud install one 10mm flat washer and 3/4" rubber washer (bushing). Insert long threaded end into pre- drilled smaller (upper) hole on Front bracket and attach with another 5/16" nut. Hand tighten. NOTE: (No Flex Compensator on Std Cab Installations)
- 2) Mount Front Flex Compensator to Rear Mounting bracket. (See illustration page 2) Locate 4.75" double threaded stud and install one 3/8" serrated flange nut on each end and thread down to end of threads. On short threaded end of stud install one 10mm flat washer and 3/4" rubber washer (bushing). Insert long threaded end into pre- drilled smaller (upper) hole on rear bracket and attach with another 3/8" serrated flange nut. Hand tighten.
- 3) Remove the 4 existing body mount bolts from frame mounting locations located under cab of the truck. Retain factory bushings, and steel washer plates. Mount Front and Rear Mounting brackets to body mounts with 4 new 12mm body bolts provided as shown in diagram using 12mm flat washers and 12mm lock washers supplied in kits. Reuse factory bushings and steel washer plates.
- 4) Bolt front bracket (short) and rear end of bar to rear bracket (longer) with 12mm tube bolts, flat washer and lock washers supplied in kit using bottom holes on the mounting brackets as the bolt through location. Hand-tighten only at this point to ensure proper adjustment later.
- 5) Bushings on front and rear flex compensator studs should be resting on vertical inclined surface of Frame Rail area under bolt-through body mounting location. When properly installed, this safeguards against any flex, reduces vibration and also allows for angle adjustment if necessary. (Note: Stud will be recessed approximately 3/16" from end of rubber washer-bushing.)
- 6) After insuring that all parts are properly aligned and tube is level, tighten all bolts. Recommended torque 65ft-lbs for tube step to bracket bolts and 45ft-lbs for Bracket to body bolts. Lock stud assembly in position by tightening bolts and studs. You may now use front and rear Flex Compensator studs to adjust bar angle if needed.

**Please Note: Some hardware kits include extra parts that may not be used in your install. Follow the instructions carefully and ensure you use all the necessary components, if there are spare parts please disregard them**

# 2002-08 Dodge Ram Quad Cab Pick up-4 Dr

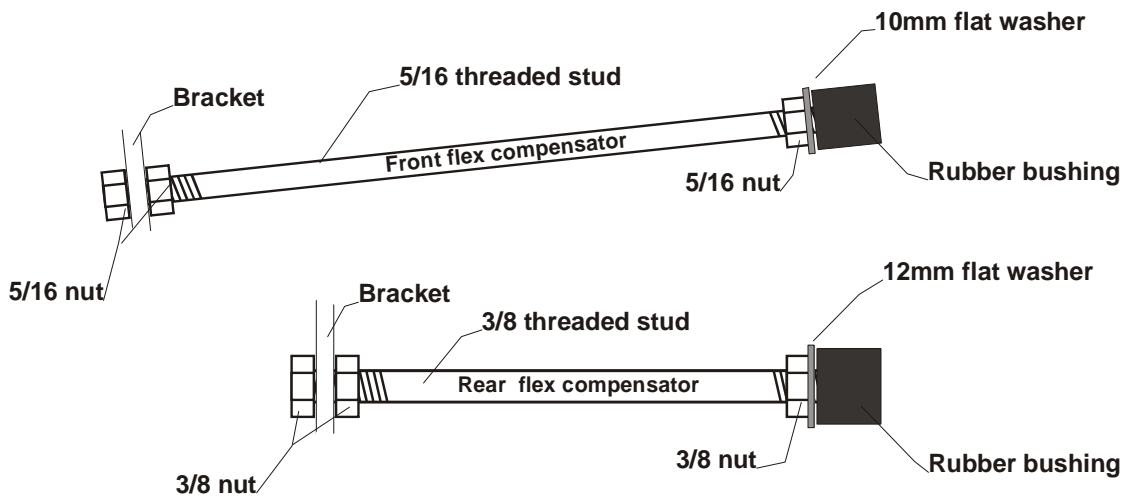
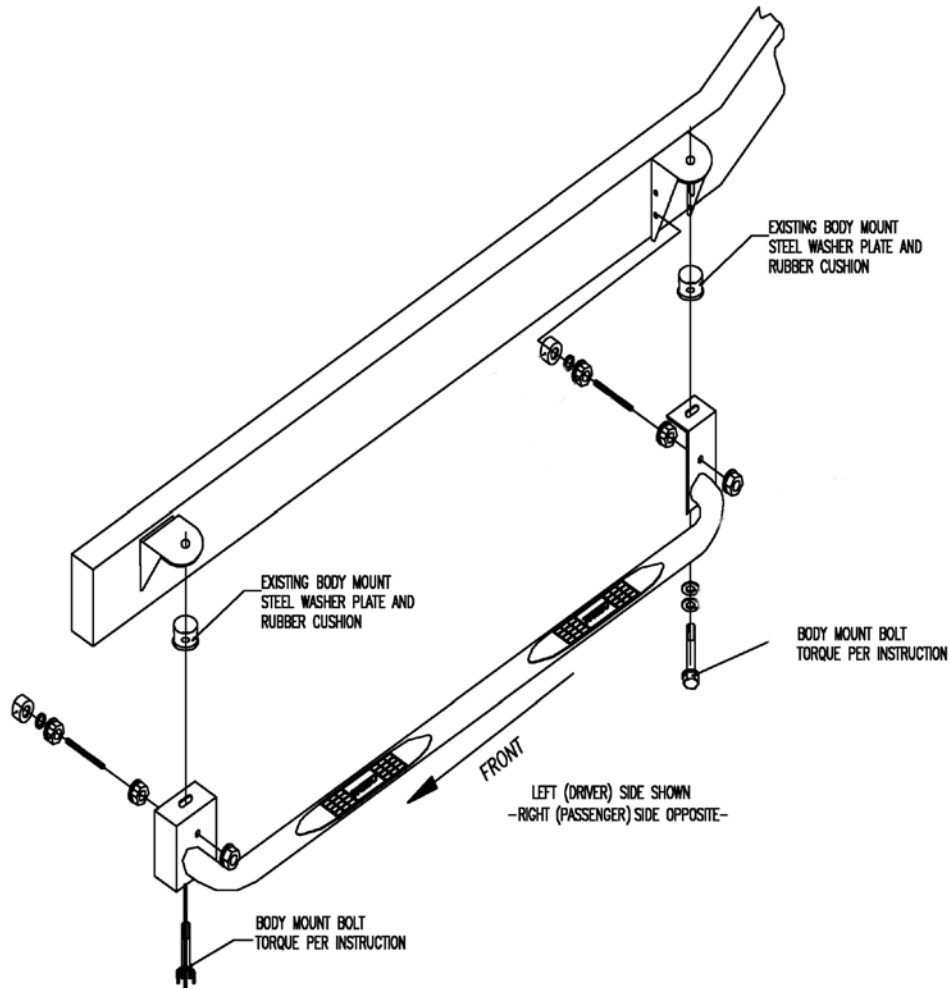

Rampage Products, LLC 9225 Stellar Court Unit C, Corona, CA 92883-4919  
 Phone: (951) 277-4949 Fax: (951) 277-2295  
 Web: [info@rampageproducts.net](mailto:info@rampageproducts.net)  
 Made in China