

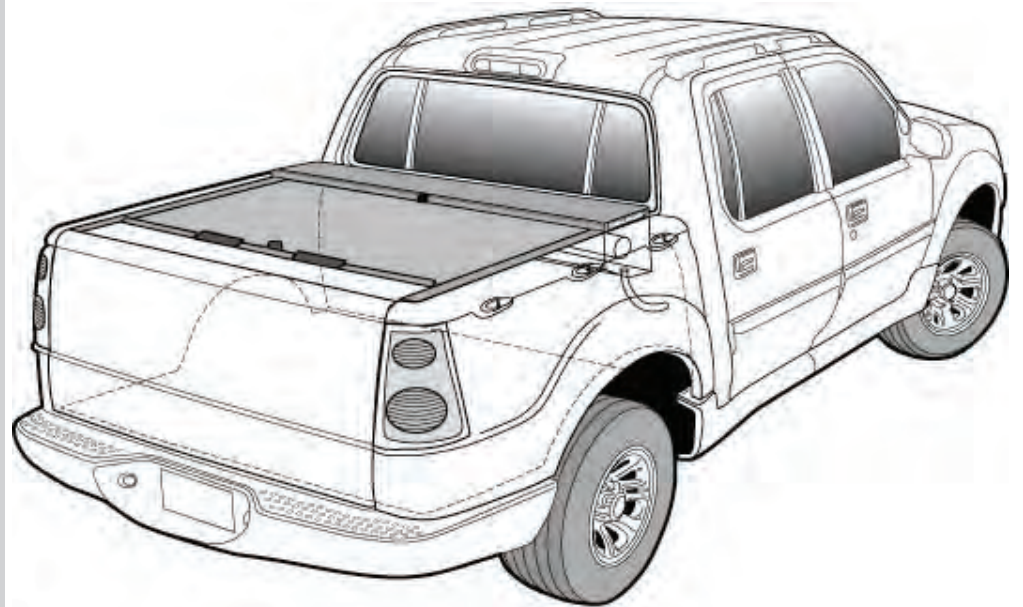

**2000-2005  
SportTrac  
Installation Guide**



**PRODUCT CODE:**

**175**



Revised June 2007

**ROLL-N-LOCK CORPORATION**  
915 South Dixie Highway E • Pompano Beach, FL 33060  
800-952-7655 • [www.rollnlock.com](http://www.rollnlock.com)

## Step One: Attaching mounting flanges and placing housing

First, remove the backing from the gasket tape on the back of the mounting flanges as shown in **diagram 1**.

Next, adhere the mounting flanges to the down flanges of the bed rails, being sure to keep the top edge of the flanges exactly flush with the top of the bed rails as shown in **diagram 2**. Notice that the flanges are marked: driver's side and passenger's side.



diagram 1



diagram 2

With the flanges in the correct location, use the #8 X 3/4" drill point button head screws to secure the flanges as shown in **Diagram 3**.

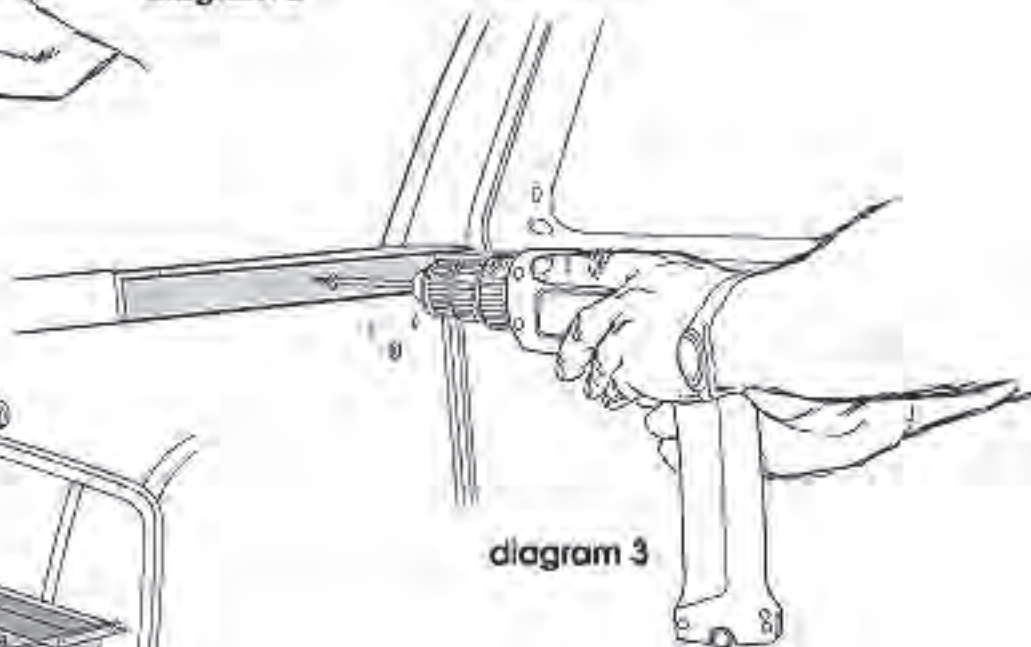

diagram 3

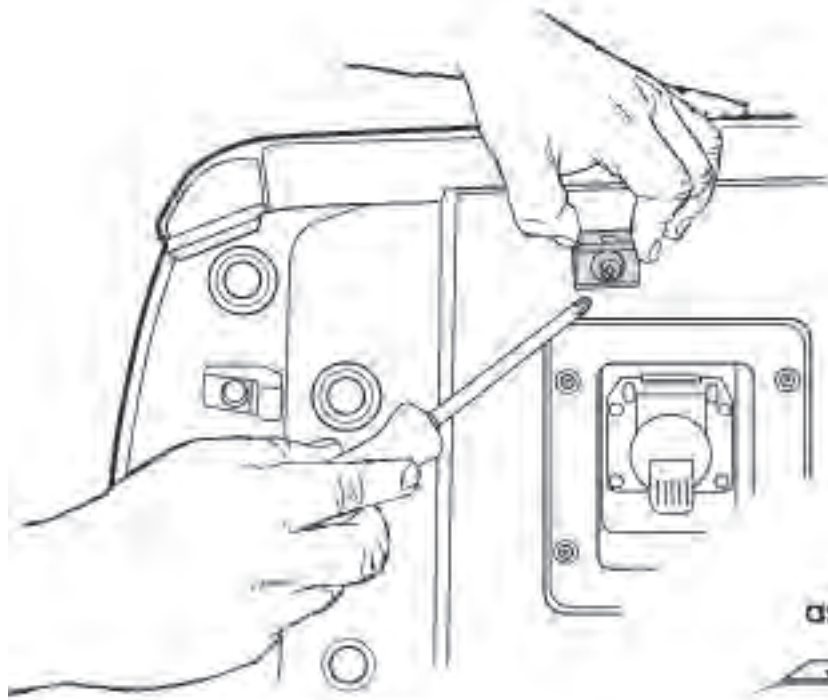
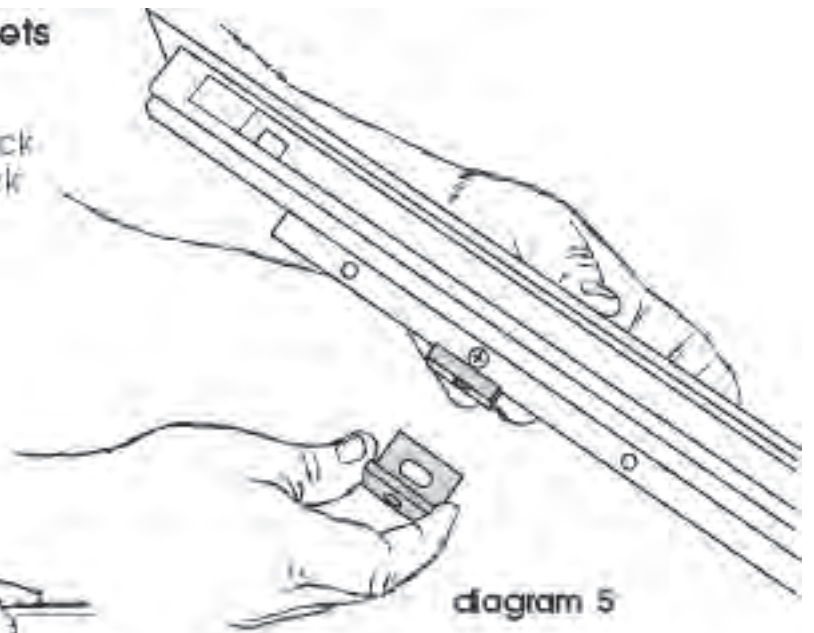

diagram 4

When both flanges have been secured, place the housing on the flanges, being sure it is centered between the rails as shown in **diagram 4** (but do not fasten at this time). **Be sure to remove wooden packaging support located behind back flange of housing.**

## Step Two: Attaching track brackets and securing tracks

Remove the bed bracket from the track as shown in **diagram 5**. (Note: the track bracket remains on the track).



Now, place the rectangular spacer/washer over the threaded bushing located at the rear of the bed, and attach the bed bracket using the 1/4" washer and 6mm X 30mm phillips head screw, as shown in **diagram 6a & 6b**.

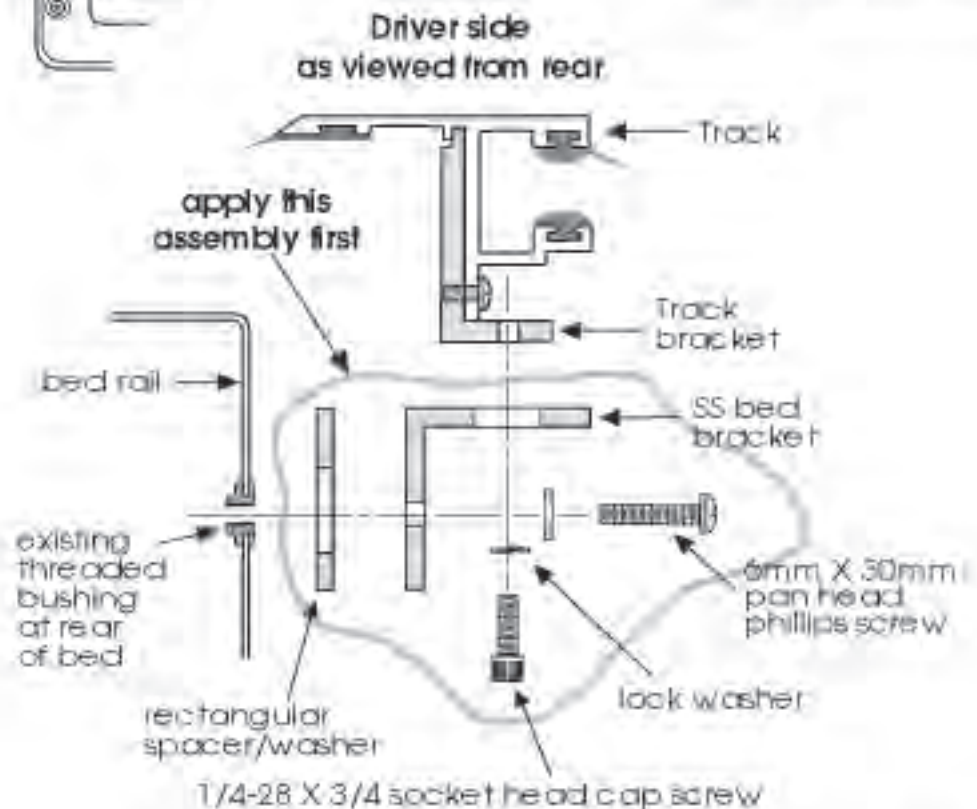
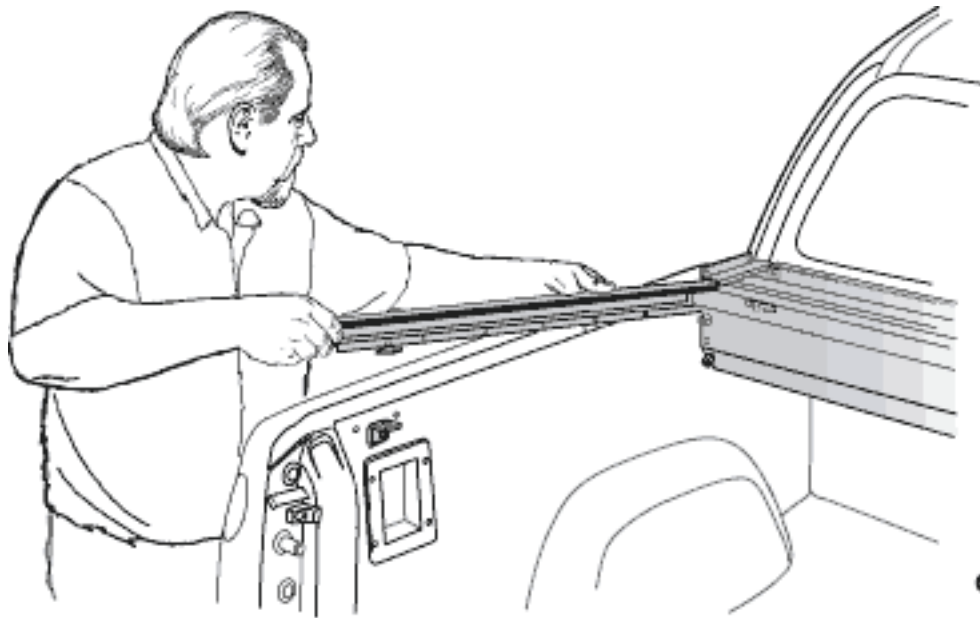

diagram 6b



**diagram 7**

With both brackets secured, key the flared end of the tracks onto the housing stems (stem goes on back side of track) being sure to carefully feed the handle into the throat of the track, as shown in **diagram 7**.

Place the tracks onto the bed rails so that the track brackets sit upon the bed brackets as shown in **diagram 8**. Secure the track brackets to the bed brackets using the 1/4" lock washers and 1/4-28 X 1" socket head screws.

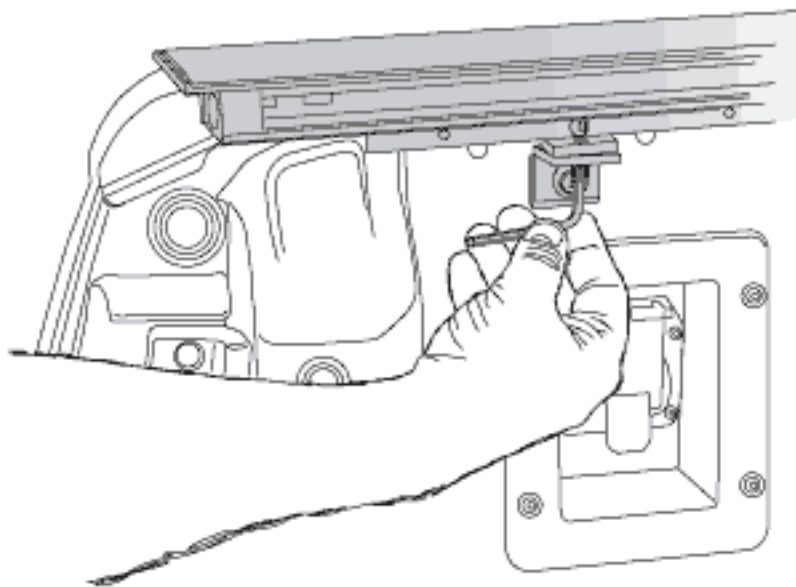

**diagram 8**

diagram 9a

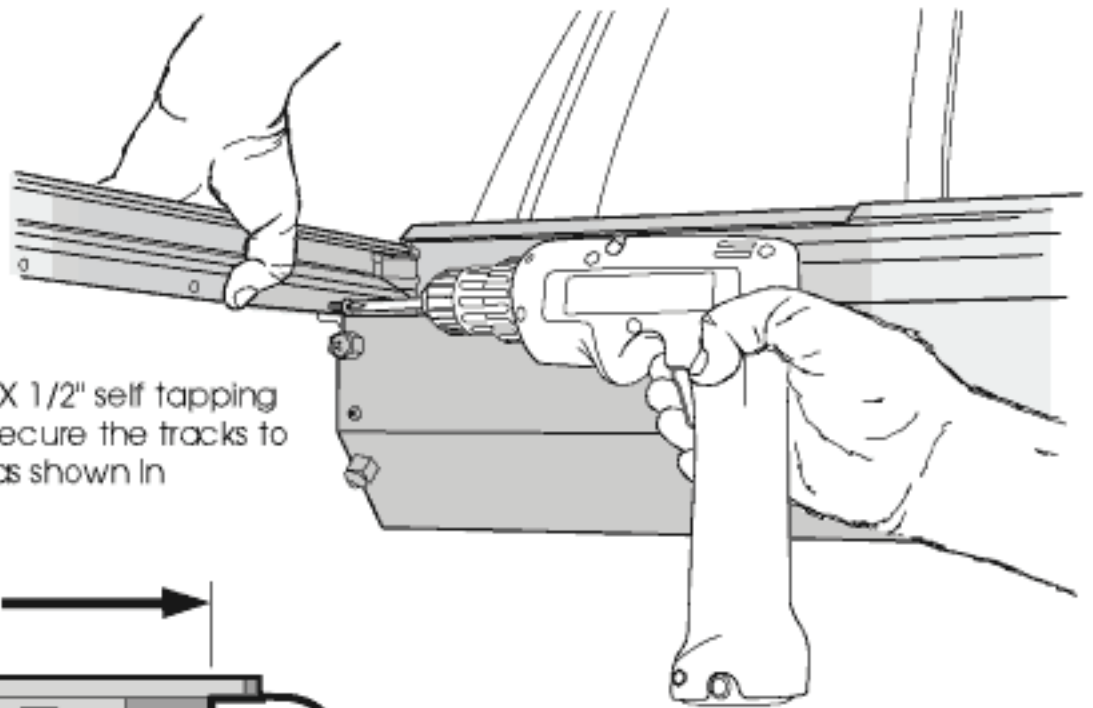

Next, using the #12 X 1/2" self tapping pan head screws, secure the tracks to the housing stems as shown in **diagram 9a**.

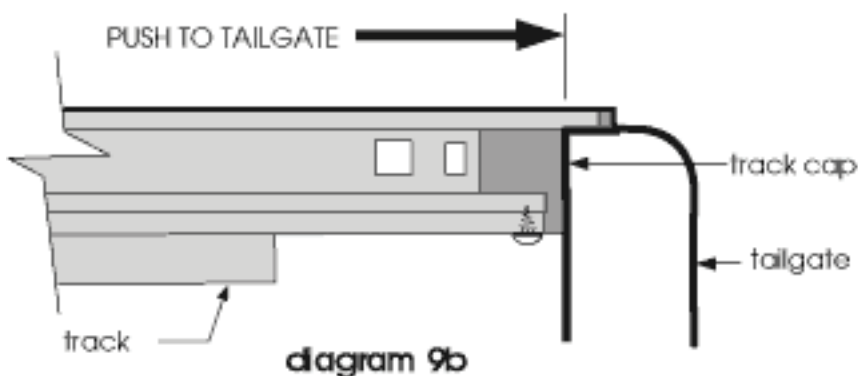

diagram 9b

**Important:** Before moving on, you must be sure that the vertical face of the track caps (green dots) are touching the vertical face of the tailgate as shown in **diagram 9b**. This may require that you loosen and reposition the bed bracket shown in **diagram 6a & 6b**. If each track is not located with the cap touching the tailgate, the lock mechanism will not function properly. With the tracks properly located, use the holes provided and the #8 X 3/4" drill point button head screws, and being sure to hold the tracks perpendicular to the bed rail, secure the tracks to the mounting flanges as shown in **diagram 10**.

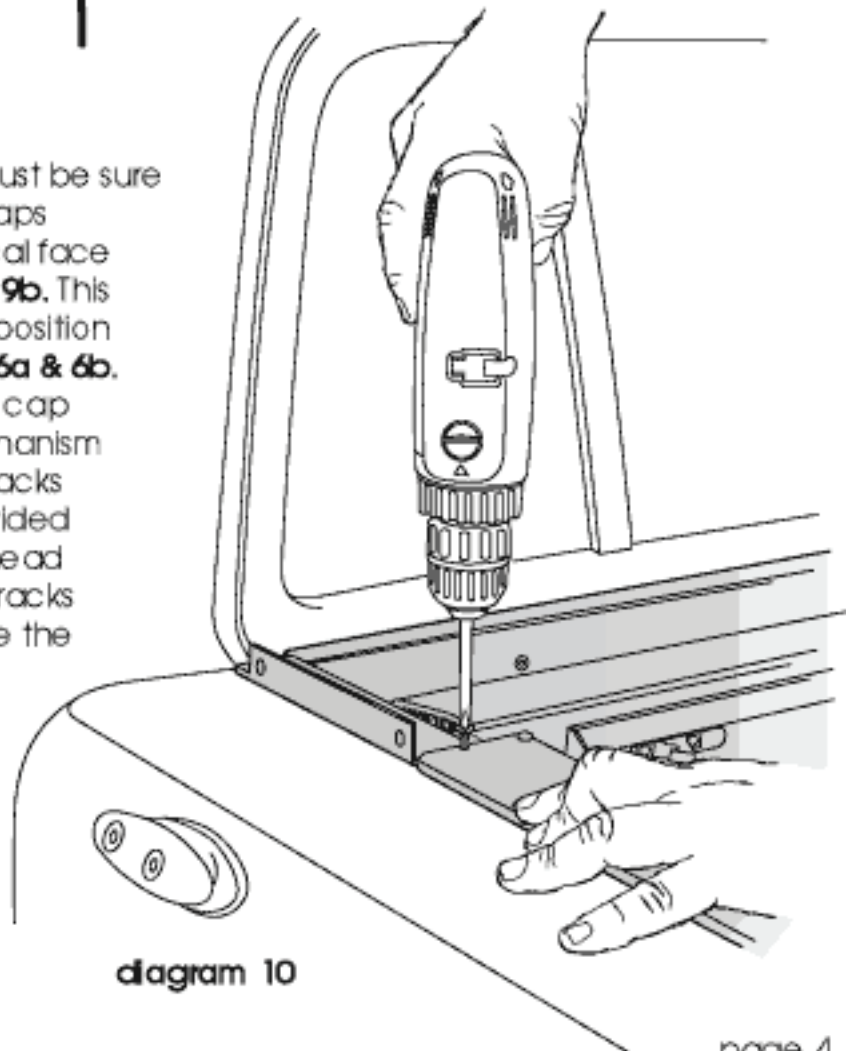

diagram 10

### Step three: Installing the tailgate extrusion (Illustration Shown is Ford Supercrew)



diagram 11

The tailgate extrusion is the most critical part of the installation process and must be done correctly for the lock mechanism to work properly. The first step is to slip the flange of the tailgate extrusion under the edge of the plastic tailgate panel (unique to this vehicle). Next, center the extrusion on the tailgate, and while holding it perpendicular fasten the center screw as shown in **diagram 11**. Again being sure to hold the extrusion perpendicular and formed down against the tailgate, fasten each end before securing the remaining fasteners as shown in **diagram 12**. This process is also thoroughly described on [page 6, Standard Installation Guide](#).

With the tailgate centered and secured, loosen the 1/4 - 28 socket head screws shown in **diagram 8** and shift the tracks inward (toward center) so that the biased face of the track caps contact the biased face of the tailgate extrusion end caps as shown in **diagram 13**. Re-tighten the tracks in this location.

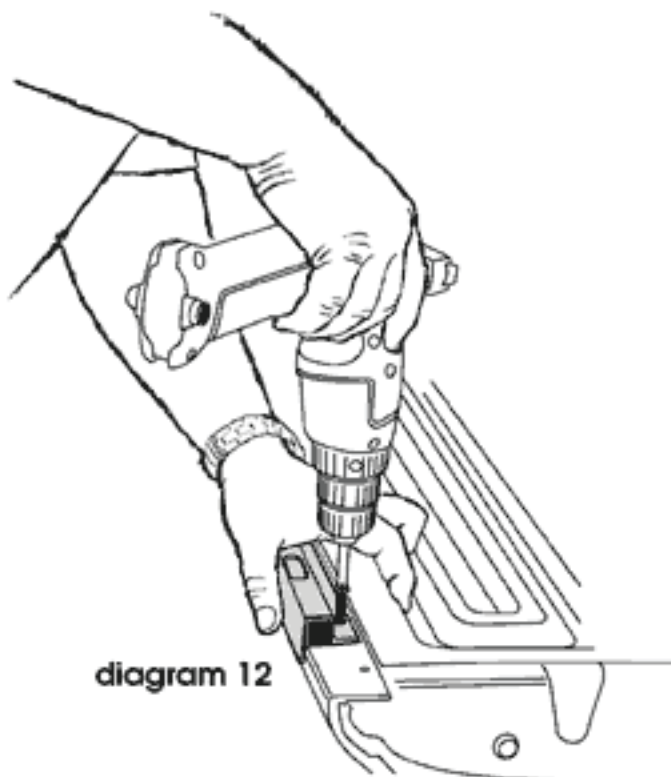

diagram 12

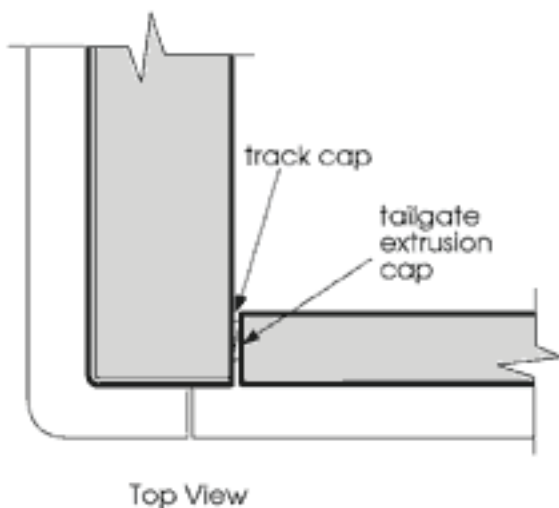
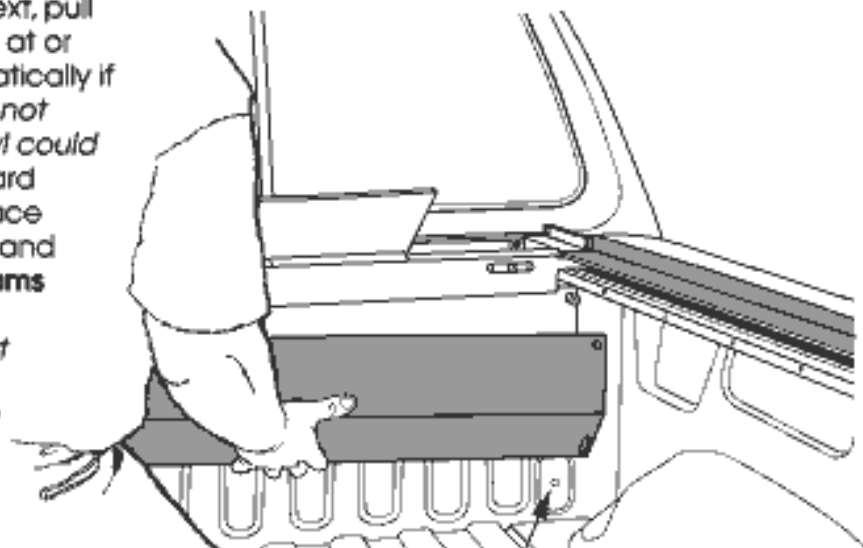

diagram 13

#### Step Four: Securing the cargo shield and housing lid. (Illustration shown is Ford Supercrew)

With the tracks in place, you can now install the cargo shield as shown in **diagram 14**. Notice that the elongated holes are on the bottom, and the rubber washers go on the inside of the shield. The easiest way to install the cargo shield is to place the truss head bolts through the holes in the shield and press or thread the rubber washers onto the threads of the bolts as shown on [page 10, Standard Installation Guide](#). Next, pull the cover out of the housing and latch it at or near the tailgate (latches will fire automatically if lock lever is in the 7 o'clock position). *Do not allow the cover to retract yet, as the vinyl could be damaged.* Now, remove the cardboard packing which is in the housing. Next, place the housing lid onto the housing flanges and align the flange holes as shown in **diagrams 15 and 16**. Use the 1/4-20 X 5/8" black counter sunk screws to secure the lid, **but do not use a screw gun and do not overtighten**, as the lid must occasionally be removed to inspect for debris.



**diagram 14**

Drill 1/2" hole in bed to provide drain tube exit point. Drain tubes connect to fittings at each end of the housing. For additional information, refer to [page 4, Standard Installation Guide](#).



**diagram 15**

Your cover is now operational and if you have followed the instructions carefully, it will function smoothly and will latch effortlessly. We recommend that you use the 303 vinyl protectant which was provided to remove finger prints and give the cover an initial cleaning. 303 should also be applied to the top and bottom track runners. Regular application of 303 will keep your Roll-N-Lock cover looking like new. Enjoy your Roll-N-Lock®

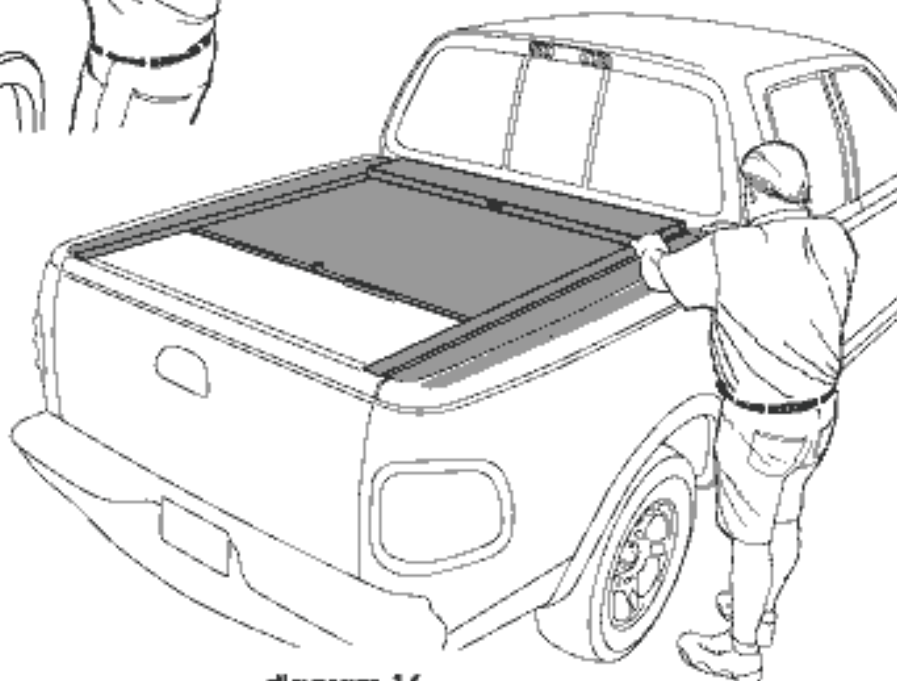

**diagram 16**

## HARDWARE COMPONENTS & DESCRIPTION



- (2) Keys  
to secure latch in locked position



- (14) #8 X 3/4" drill point button head screw  
for attachment of mounting flange to bed rail and tailgate extrusion to tailgate



- (2) #12 X 1/2" self tapping pan head screw  
for attachment of track to reel support stem



- (2) 1/4" lock washer  
for attachment of track bracket to bed bracket



- (2) 1/4 - 28 X 1" socket head screw  
for attachment of track bracket to bed bracket



- (2) 6mm X 30mm pan head Phillips head screws  
for attachment of bed bracket



- (4) 1/4 - 20 X 5/8" countersunk self tapping screw  
For attachment of lid to housing flange



- (4) Rubber washers  
for cargo shield assembly

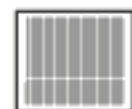

- (1) Pull strap holder pad  
for securement of pull strap to rear of bed



- (2) Drainage tubes  
for drainage of Housing, at left and right corners



- (2) 1/4" Washers  
for attachment of bed bracket



- (1) 3/16" Hex key  
for tightening of track bracket to bed bracket



- (2) Rectangular spacer / washer  
for attachment of bed bracket



- (1) 303 Vinyl protectant  
To clean and preserve vinyl  
(Give to customers)

# ROLL-N-LOCK CORPORATION

Phone: 800-952-7655 Fax: 954-943-3675

All contents © 2001 Roll-N-Lock Corporation