



Installation Guide



2007 - Current Ford Sport Trac

PRODUCT CODE: **176**



July 2007

ROLL N LOCK CORPORATION
915 South Dixie Highway E • Pompano Beach, FL 33060
800-952-7655 • www.rollnlock.com

Installation Guide

Tools Needed:

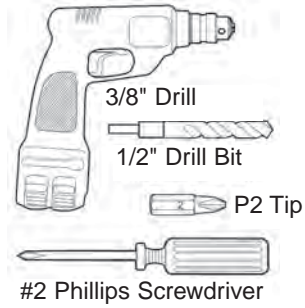

Components Included:

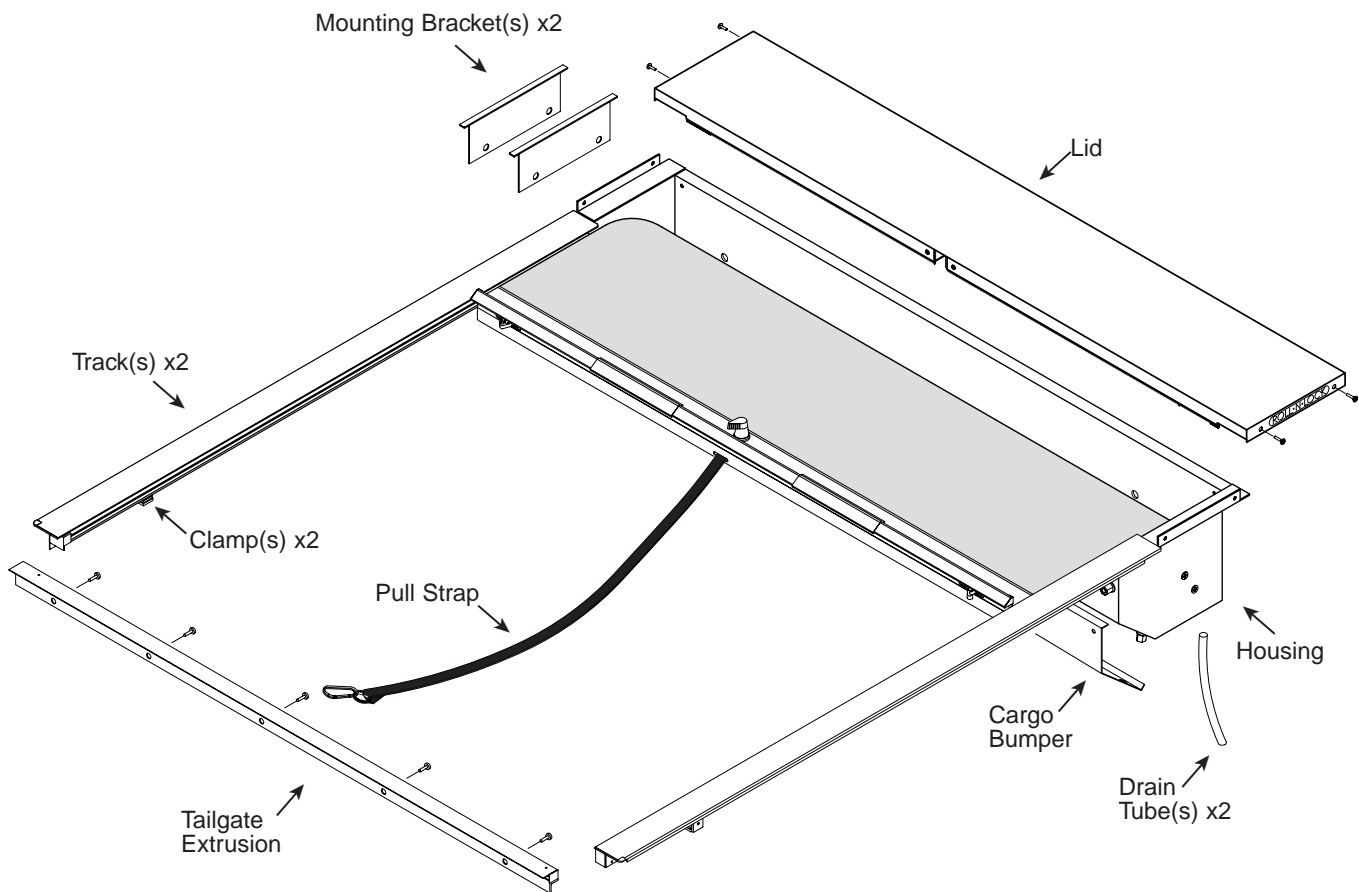

Step 1: Preparing the Bed for Installation

- A.** Press butyl caulking strips into the seams between the bulkhead and bedrails (*Photo 1*).
- B.** Use 6mm x 25mm Philips head screws and large fender washers to secure one forward mounting bracket on each side (*Photo 2*).
- C.** Use 6mm x 25mm Philips head screws and small washers to loosely secure one rear mounting bracket on each side (*Photo 3*).

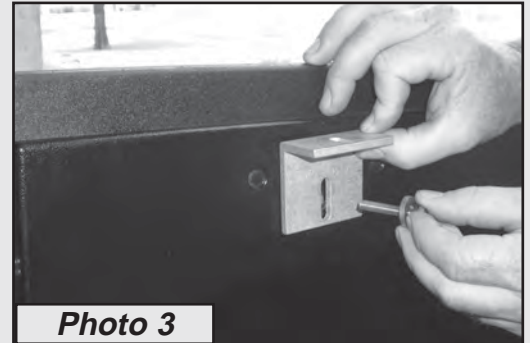
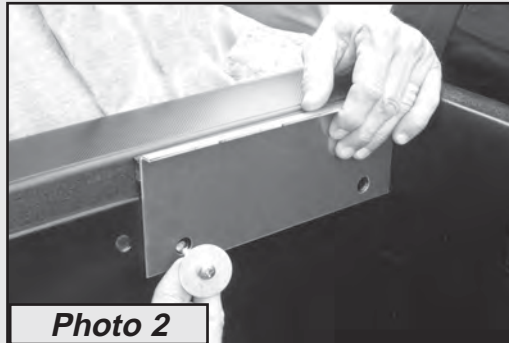
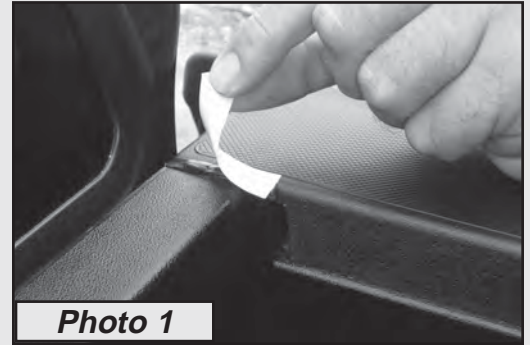

Step 2: Placing and Preparing the Housing Assembly

- A.** Place the housing assembly onto the forward mounting brackets (*Photo 4*), centering it between the two, with the housing's back flange overlapping the bulkhead. This is best accomplished with two people.
- B.** Remove the lid from the housing and discard the plastic packing bolts (*Photo 5*).
- C.** **Being sure to leave the pull-strap connected to the threaded shipping stud;** rotate the lock lever to the 10 o'clock (open) position (*Photo 6*).

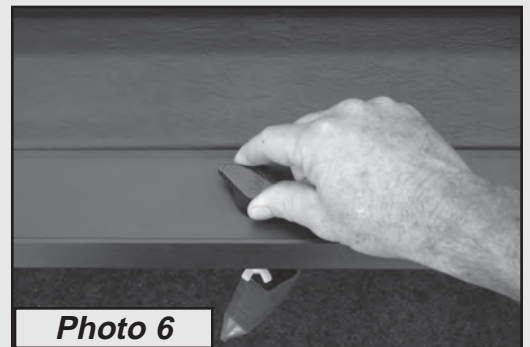
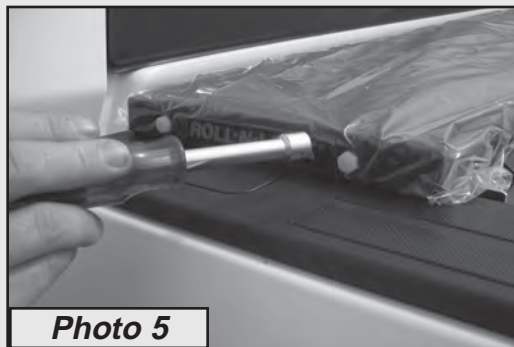

Step 3: Installing the Tracks

- A.** Carefully place the driver's side track onto the bed rail (**Photo 7**) and key it onto the housing stem (**Diagram 8**) being sure that the handle is properly engaged into the tracks.
- B.** Use a 10-24 x 1/2" Truss head screw and cargo nut to secure the tracks to the housing stem (**Photo 9**). Tighten this connection securely.
- C.** Use a 1/4-28 x 1/2" socket head screw and lock washer to secure the track clamp to the back mounting bracket (**Photo 10**) **Note: The mounting bracket is equipped with a slotted hole to permit vertical adjustment.** Hold the track so that it is perpendicular (square) to the bed rail and so that it does not interfere with the operation of the tailgate. Tighten the bracket in this position (**Photo 11**).
- D.** Use a #8 x 3/4" self-tapping screw to secure the track to the forward mounting bracket (**Photo 12**).
- E.** With the driver's side track in place, repeat sub-steps A through D for the passenger's side track.

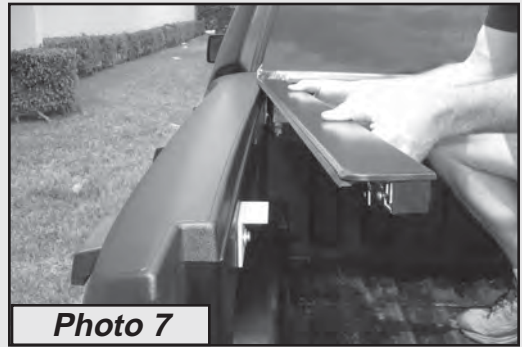

Photo 7

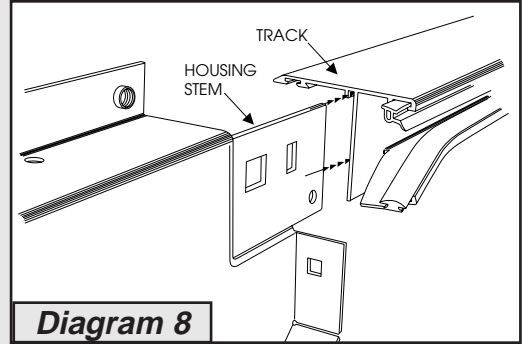

Diagram 8

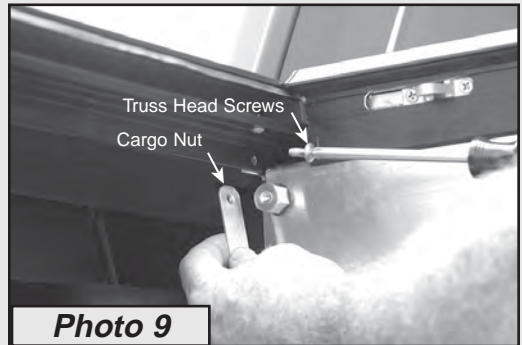

Photo 9



Photo 10

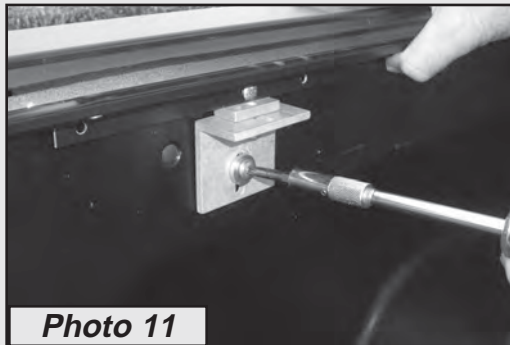

Photo 11

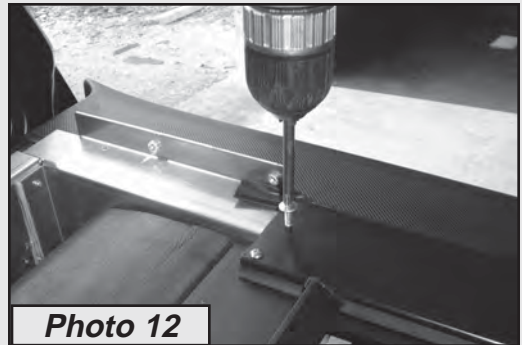
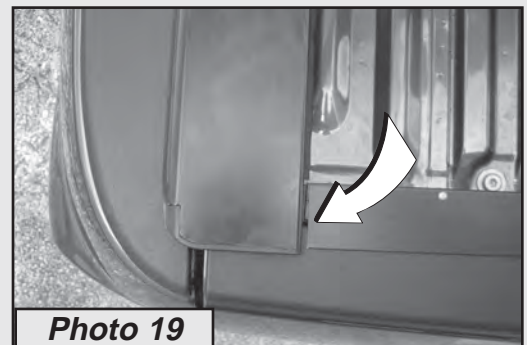
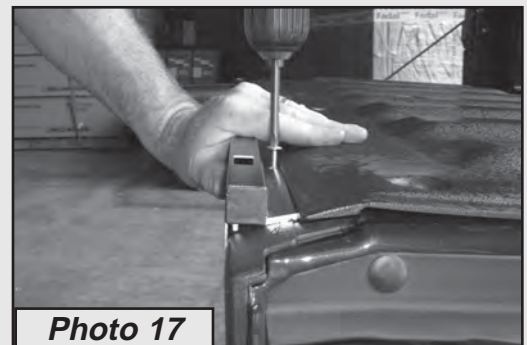
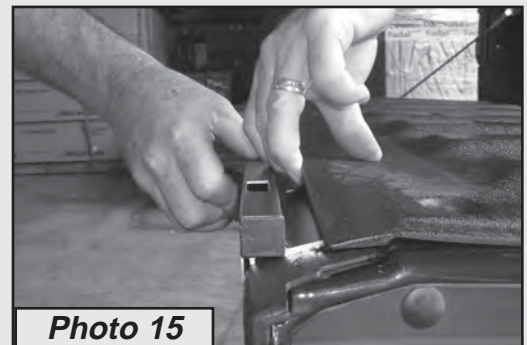
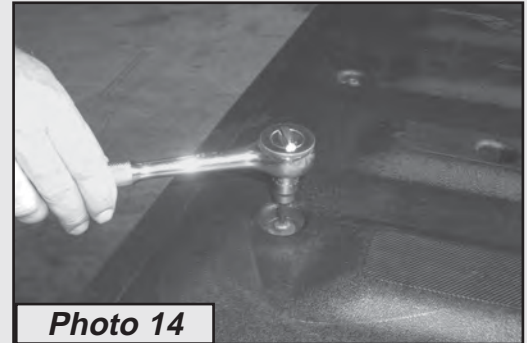

Photo 12

Step 4: Installing the Tailgate Extrusion

- A.** Measure, locate and mark the center of the tailgate and tailgate extrusion (**Photo 13**).
- B.** Loosen the tailgate protector panel (**Photo 14**) and slide the tailgate extrusion flange under the edge of the panel (**Photo 15**).
- C.** Align the center mark on the tailgate extrusion with the center mark on the tailgate. Being sure to hold the extrusion tight and square to the tailgate, use a power screw gun and #8 x 3/4" self-tapping screw to secure the hole nearest the center (**Photo 16**). Next, secure the holes nearest the ends, again being careful to hold the extrusion tight and square to the tailgate (**Photo 17**), and then secure two additional holes.
- D.** With the tailgate closed, loosen the 1/4-28 x 1/2" socket head screws which secure the tracks to the back mounting brackets (**Photo 18**) and shift the tracks in so that the track end caps contact the tailgate extrusion end caps (**Photo 19**). Tighten the clamps in this position. **Note: If the tracks are not positioned as shown, the lock mechanism will not function correctly.**



Step 5: Installing the Housing Lid, Cargo Bumper and Drain Tubes

- A.** Rotate the lock lever to the 7 o'clock (latched) position (*Photo 20*), then remove the plastic wing-nut and detach the pull-strap from the threaded stud (*Photo 21*). Pull the cover closed and latch it to the tailgate.
Note: Do not allow the cover to retract without the housing lid in place.
- B.** Place the lid onto the housing flanges (*Photo 22*) and secure it in place with 1/4-20 x 5/8" black countersunk screws. **Do not use a power or pneumatic screw gun to drive the screws.** Turn the lock lever clockwise to the 10 o'clock position and open the cover.
- C.** Use a 1/4 - 20 x 1/2" truss head screws and rubber washers to secure the cargo bumper (*Diagram 23*).
Note: The rubber washers go on the inside of the Cargo Bumper.
- D.** Use a 1/2" bit to drill two holes for the drain tubes (*Photo 24*). This process is easier if a 1/4" pilot hole is drilled first. **Note: Holes are to be drilled in line with the drain tube fittings, about 3-4 inches below the housing.**
- E.** Always make sure the pull-strap is securely clipped to a fixed point in the bed.

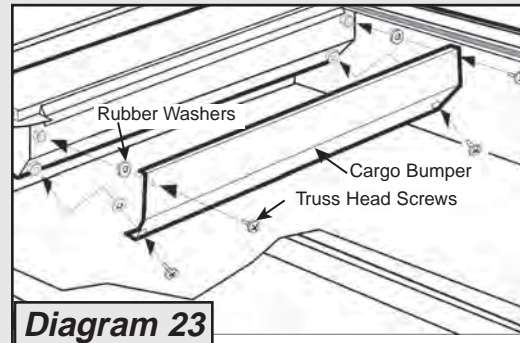
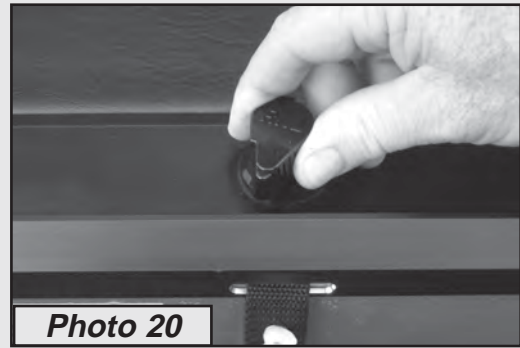

Step 6: Testing Operation

In Step 5, the cover was opened (retracted). This would have caused the lock lever to enter the lock pocket and rotate to the 7 o'clock (latched) position.

- A.** To close the cover, pull the pull-strap hand-over-hand, allowing the excess strap to fall into the bed until you can reach the handle. Place your hands evenly spread on the handle and pull the handle until it contacts the tailgate extrusion. As the handle contacts the tailgate extrusion, the spring loaded latches (which were energized when the cover was retracted) will automatically trip, simultaneously latching the cover to the tailgate and side tracks.
- B.** To open the cover, pull back slightly on the handle to relieve spring tension from the latch mechanisms and turn the lock lever clockwise to the 10 o'clock position. The cover should retract on its own with only a slight push to set it into motion. When the cover is retracting, it is best to hold the pull-strap and allow it to slip through your fingers as the cover travels. Applying pressure to the pull strap as it slips through your fingers will act as a breaking action, preventing the handle from slamming into the lid at high speed. The cover must retract with only enough force to rotate and reset the lock lever and latching mechanism.

Note: If your cover fails to function as described, it is likely that some part of the installation instruction was overlooked or improperly performed. Please call our technical department at (800) 952-7655 for assistance.

Don't Forget the Hang Tag!

Eliminate come-backs by giving your customers a friendly reminder of how to use and maintain their new **ROLL-N-LOCK**® retractable cover for maximum satisfaction. This hang-tag will get noticed immediately on the rear view mirror of your customer's pickup, providing them with everything they need to know.

**The Tonneau installer's
best friend!**



HOLD YOUR CARGO SECURELY WITH...

CARGO / MANAGER®



CARGO MANAGER®, a companion product for **ROLL-N-LOCK®**, is a movable bed divider that can be positioned at any point along the length of the truck bed to manage and contain lightweight cargo.

- **Easy Positioning**
- **Adjustable Tie-Offs**
- **Flip-Up Feature**
- **Easily Removable**

Weighing only 11 pounds, the **CARGO MANAGER®** can be easily removed when the entire bed space is required.

See your ROLL-N-LOCK® dealer today!



ROLL N LOCK CORPORATION
915 South Dixie Highway E • Pompano Beach, FL 33060
800-952-7655 • www.rollnlock.com