

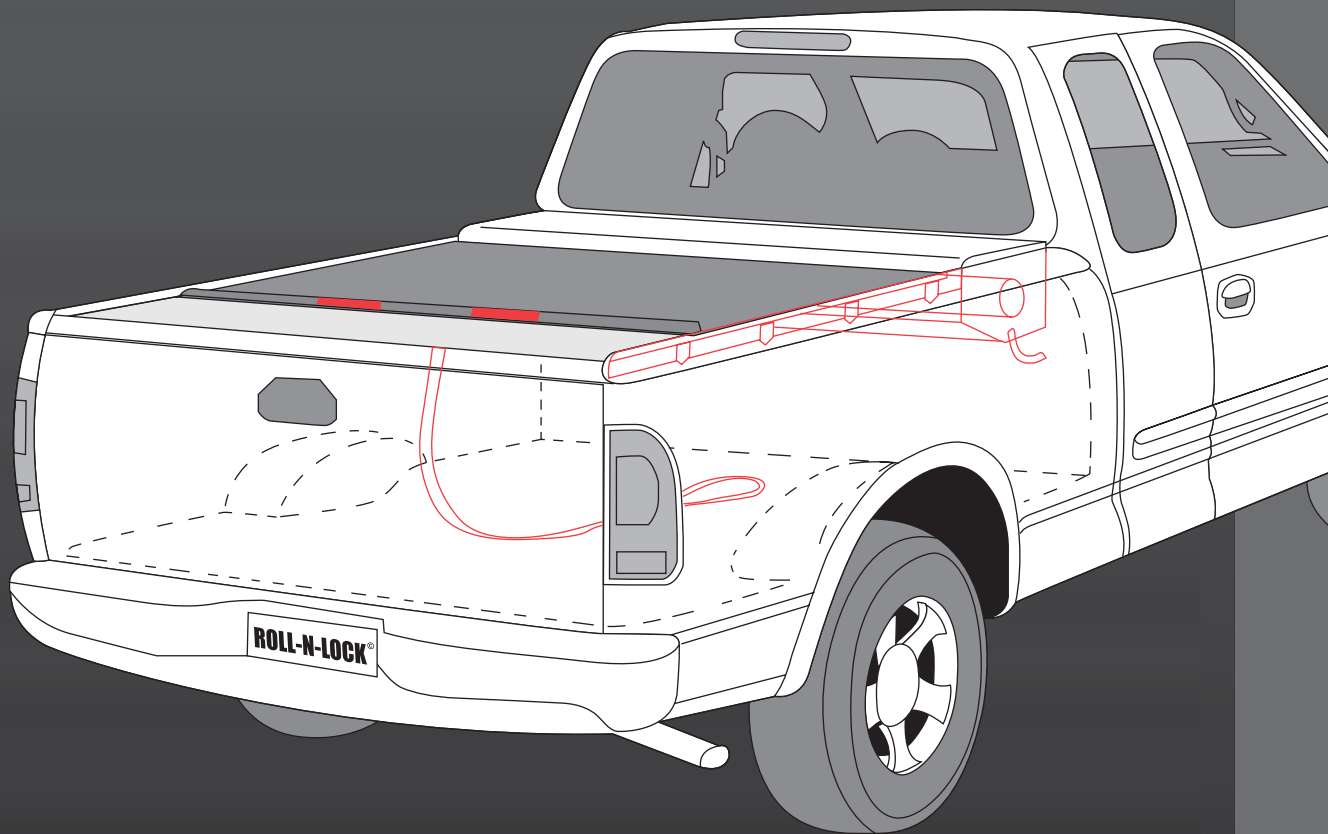

INSTALLATION GUIDE
1997-2003 FORD
F-150 FLARESIDE



PRODUCT CODE:

145



May 16, 2011

STEP 1:

Assemble sub-frame by attaching the cross members to the tapered Mounting Flanges (**Diagram #1.**)

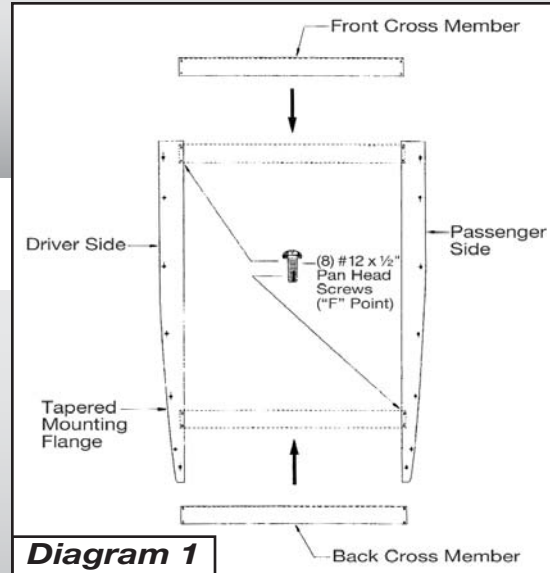

Diagram 1

STEP 2:

Place assembled subframe onto the truck bed and shift the frame back to tailgate, the subframe will generally center itself at the rear of the bed but must be centered at the front.

To center the frame, count the rail cap striations and make sure that you have the same amount on each side. To center, the exposed striations on each bed rail must be equal (**Diagram 2.**)

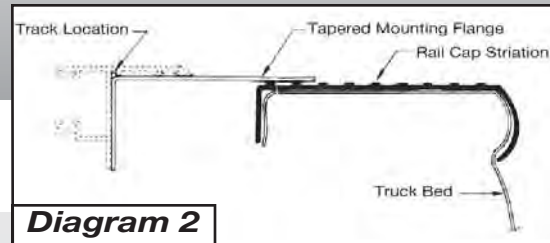

Diagram 2

Step 3:

When the subframe is in the correct position (*centered from side to side and back against the tailgate*) it is ready to be fastened. To fasten, first drill the mounting hole closest to the tailgate using the No. 18 drill bit provided and securing with the black 1/4" - 20 x 5/8" flat head Phillips screw (**Diagram 3.**)

Caution: If a power screw gun is used it must be set at a low torque range to avoid stripping the screws.

When the subframe installation is complete, remove the cross members (**Diagram 3.**)

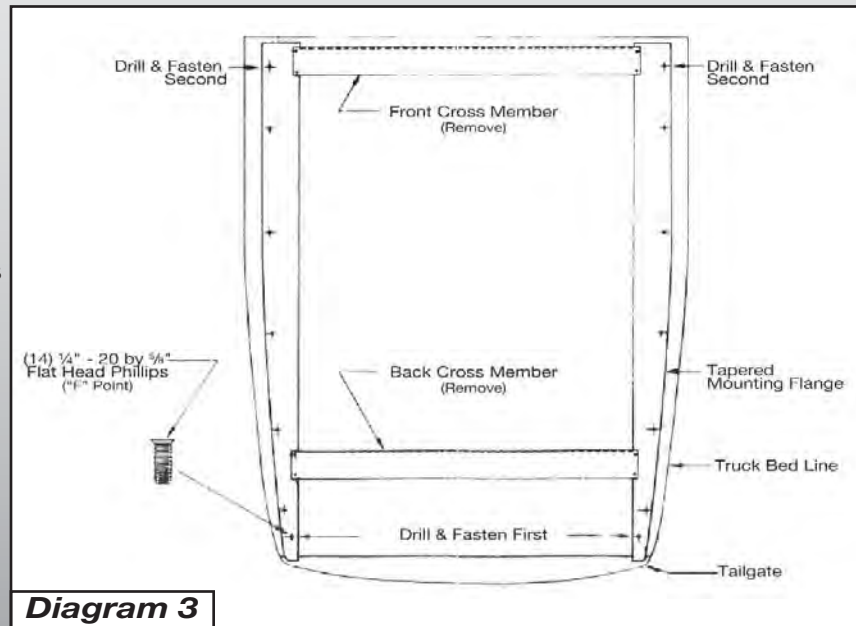
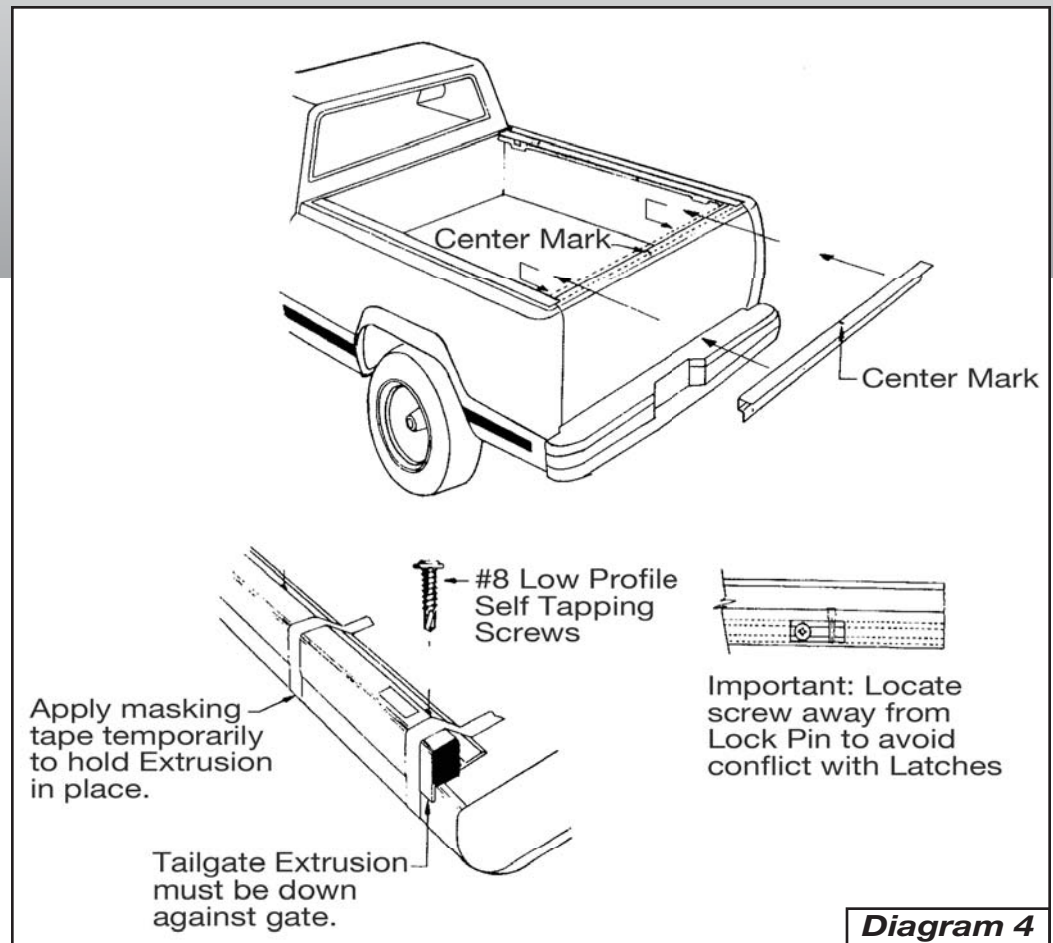

Diagram 3

STEP 4:

To position Tailgate Extrusion, place a mark at exact center of the tailgate and exact center of the Tailgate Extrusion as shown above. Center the Tailgate Extrusion on the tailgate and temporarily tape the Extrusion to the gate. Next, lower the tailgate. Beginning at the center, hold the extrusion in a perpendicular position being sure that the top Flange of the Extrusion is flat down against the top of the tailgate. Secure the tailgate Extrusion using the self threading screws provided (*screw gun required*), next secure one end of the Tailgate Extrusion being sure to form it down to match the contour of the tailgate and that it is perpendicular when secured. Do opposite end and then remaining holes.



STEP 5:

Before placing Housing onto Mounting Flanges rotate the Lock Lever to the 10 o'clock position. **Do Not remove Wing Nut yet.** Place the Housing onto the Mounting Flanges at the front of the bed (**Diagram 5**). This will require some effort as the screw heads on each end of the Housing will hit the Flanges, but it will go in with some shifting around. When the Housing is in place, shift the unit forward so the Housing Flange overlaps the bulkhead. Do not be concerned about the exact position of the Housing and do not fasten the Housing into place until Step 6 has been completed. The inside face of the tailgate will determine the actual finish location of the system as explained in **Step 6**.

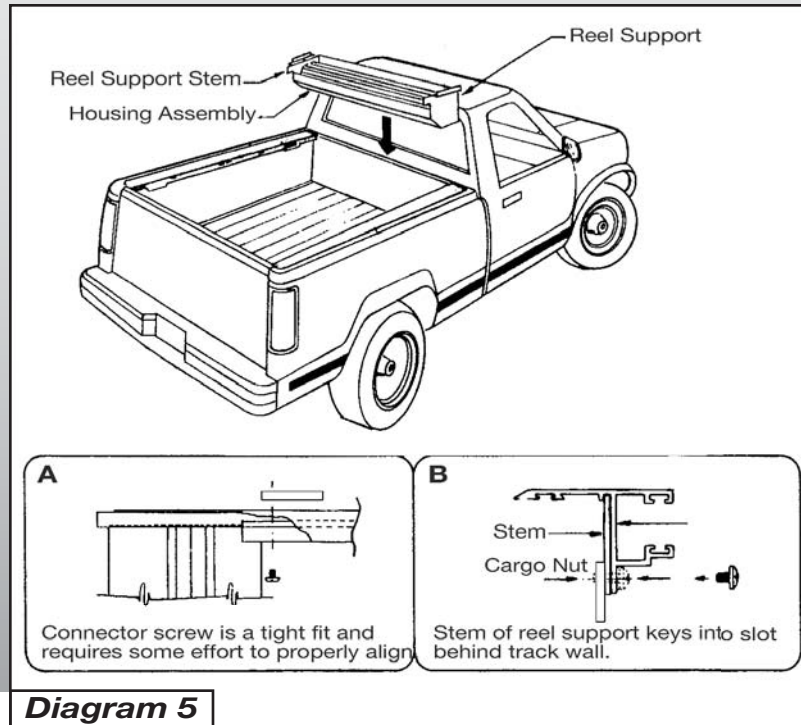

Diagram 5

Step 6:

Place the Tracks on the Mounting Flanges and key onto Reel Support Stems and fasten as shown in as shown in (**Diagram 5**) A and B. Secure the Tracks to the Mounting Flanges using the #10-24 x 1/2" truss head screws and Cargo Nut (**Diagram 6**).

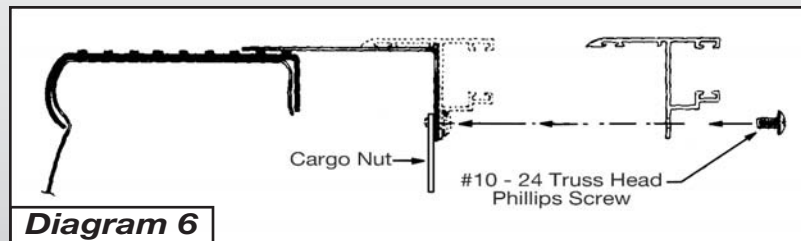

Diagram 6

Note: Connection holes in the Mounting Flanges are slotted to allow for proper positioning of the Tracks. The Lock Mechanism will not work properly if the Track End Caps are not touching the inside face of the tailgate. (Refer to Photo 6 of the Standard Installation Guide and complete the remaining installation using the Standard Guide).