



www.skyjacker.com

REQUIRED TOOL LIST:

- Safety Glasses
- Metric / Standard Wrenches & Sockets
- Floor Jack
- Jack Stands
- Measuring Tape
- Torque Wrench

**Jeep Wrangler TJ
NP231 Transfer Case
Shifter Bracket**

Kit #: JSRB231A or JSRB2315U



Before beginning the installation, thoroughly & completely read these instructions. Please refer to the Parts List to insure that all parts & hardware are received prior to the disassembly of the vehicle. If any parts are found to be missing, contact SKYJACKER® Customer Service at 318-388-0816 to obtain the needed items. If you have any questions or reservations about installing this product, call SKYJACKER® Technical Assistance at 318-388-0816.

IMPORTANT NOTES:

- The transfer case & transmission are supported by the transfer case skid plate. Before removing the transfer case skid plate, ensure that the transmission is properly supported.

Kit Box Breakdown:

Part #: JSRB231A

ITEM#	DESCRIPTION	QTY
TJSRB-1	TJ MAIN SHIFT RELOCATE BRKT	1
TJSRB-2	TJ AUX. SHIFT RELOCATE BRKT	1
HB-JSRB231A	HDWR BAG: JSRB231A T/C BRKT	1
I-JSRB231	INST. SHEET FOR JSRB231	1

Hardware Bag Breakdown:

HB-JSRB231A HARDWARE BAG

ITEM#	DESCRIPTION	QTY
516X1FTB	5/16 X 1 FINE THRD BOLT	2
516FTN	5/16" FINE THRD N/I LOCKNUT	2
38FSFTN	3/8-24 FLANGE SERRATED NUT	2
516SAEW	5/16 SAE WASHER	2
SS312-UL	JSRB SLEEVE, .312/.302 LONG	1
SS1062-UL	JSRB SLEEVE,1.062/1.052LONG	1
FSB3838	FLANGED SLV BRG 3/8" X 3/8"	2
TS38	EXT.TUBE,3.25"/FOR JSRB KIT	1

I-JSRB231 3-10

Kit Box Breakdown:

Part #: JSRB2315U

ITEM#	DESCRIPTION	QTY
TJSRB-1	TJ MAIN SHIFT RELOCATE BRKT	1
TJSRB-2	TJ AUX. SHIFT RELOCATE BRKT	1
FSB3838	FLANGED SLV BRG 3/8" X 3/8"	2
SS312-UL	JSRB SLEEVE, .312/.302 LONG	1
SS1062-UL	JSRB SLEEVE, 1.062/1.052LONG	1
TS38	EXT.TUBE, 3.25"/FOR JSRB KIT	1
516X1FTB	5/16 X 1 FINE THRD BOLT	2
516FTN	5/16" FINE THRD N/I LOCKNUT	2
38FSFTN	3/8-24 FLANGE SERRATED NUT	2
516SAEW	5/16 SAE WASHER	2
I-JSRB231	INST. SHEET FOR JSRB231	1

Installation:

1. With the vehicle on flat level ground, set the emergency brake & block the rear tires.
2. Shift the transfer case into 4 LOW. Support the transmission with a floor jack & remove the six OEM skid plate retaining bolts at the frame rails.
3. While supporting the OEM skid plate remove the nuts attaching the transmission mount to the skid plate & separate the skid plate from the vehicle.
4. Identify the items & begin to dismantle the shifter mechanism. Using a pry-bar or large screwdriver, pry the torque shaft rod from the range lever & pry the shift rod from the transfer case shift lever assembly. Remove & discard the OEM linkage bracket & the OEM torque shaft bracket. (See Photo # 1)

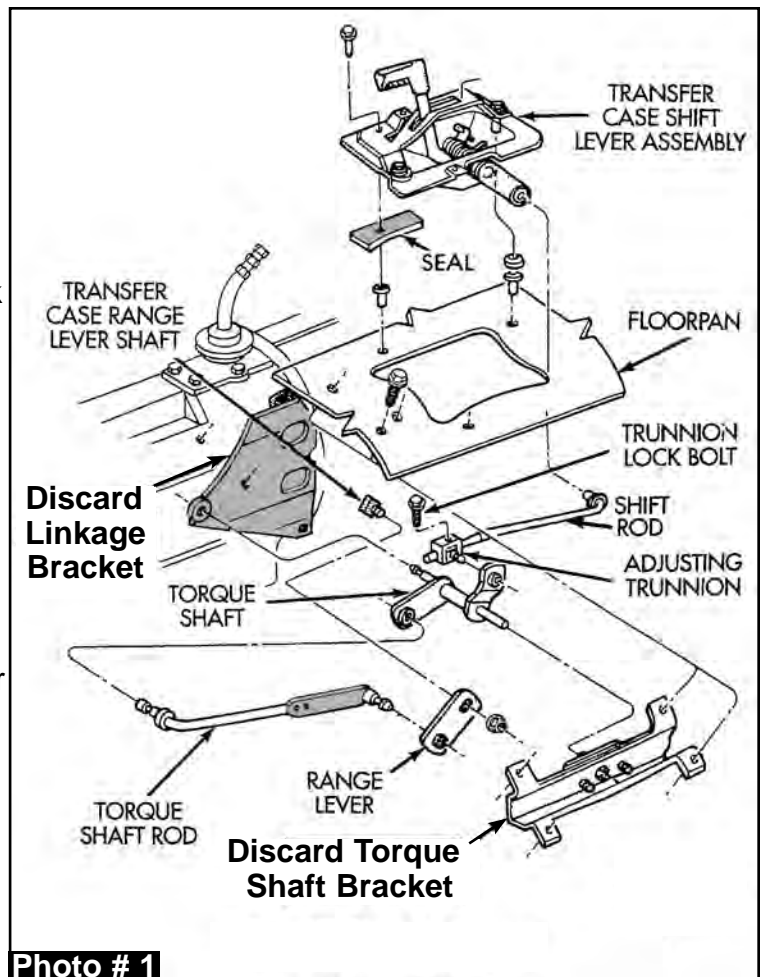

5. Insert the top-hat teflon bushings & assemble the new Skyjacker shifter brackets. (See Photo # 2 & # 3)

Note: On Unlimited Models, the two spacers provided must be used. (See Photo # 3 & # 4) The shorter spacer (.312") will be used toward the frame side of the OEM bracket & the longer spacer (1.062") will be used on the transmission side of the OEM bracket.

6. With the new Skyjacker shifter bracket fully assembled, cut both ends of the torque shaft flush with the top-hat teflon bushings & discard. **Note:** Jeep Unlimited models will not require cutting.
7. Loosen the trunnion lock bolt at the adjusting trunnion & install the assembled Skyjacker shifter bracket assembly to the OEM transfer mounting studs using the OEM hardware. Insert the torque shaft rod into the range lever & the shift rod into the transfer case shift lever assembly by using a pair of channel locks. (See Photo # 6)
8. With transmission supported, raise OEM skid plate to the frame rails & install using the OEM hardware.
9. Check that the transfer case shifter is in 4 LOW & tighten the trunnion lock bolt into position.

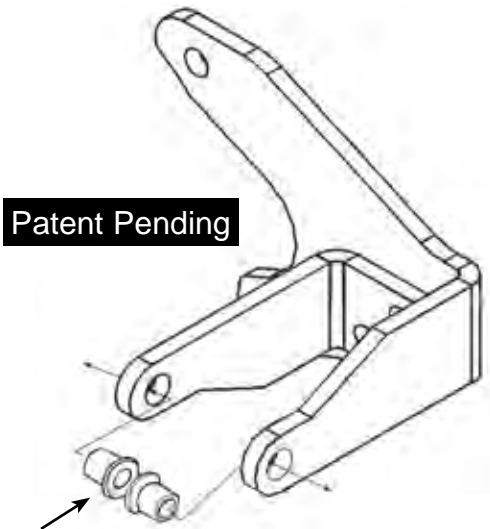

Patent Pending

Top-Hat Teflon Bushings

Photo # 2

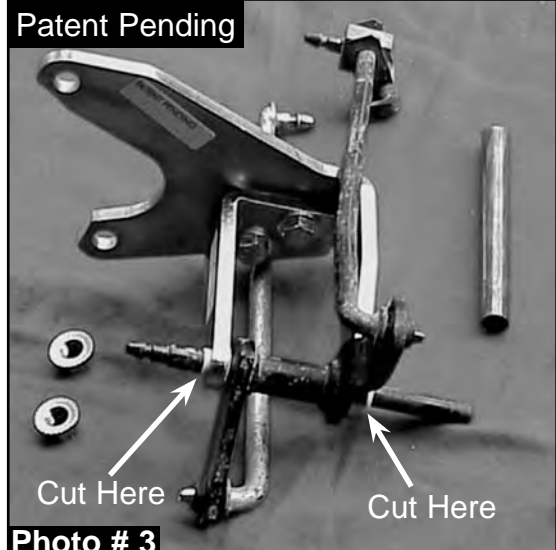

Patent Pending

Cut Here

Cut Here

Photo # 3



Photo # 4



Photo # 5

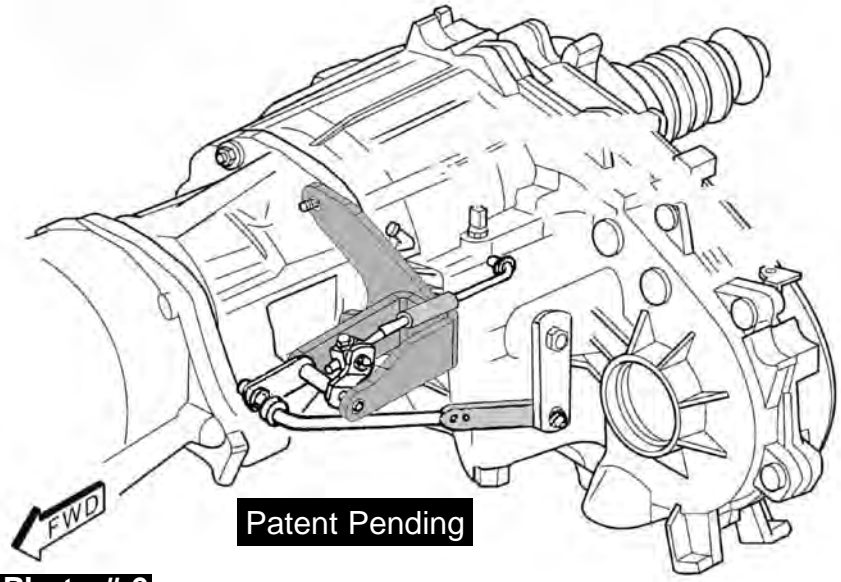

Patent Pending

Photo # 6

10. Check the transfer case shifter for proper operation thru all gear selections.

Note: Depending on the application, cutting of the shift rod may be necessary for proper transfer case shifter operation. Scribe & cut the shift rod 5 1/2" from the end of the shaft. Insert the 3/8" tube spacer, being sure that the scribe marks are in line & weld to produce the desired shaft length. (See Photo # 7 & # 8) **Cutting of the shift rod will not be necessary for Unlimited Models.**



Photo # 7

FINAL NOTES:

- After the installation is complete, double check that all nuts & bolts are tight. Refer to the following chart below for the proper torque specifications. (Do not retighten the nuts & bolts where thread lock compound was used.)
- Retorque all the bolts after the first 100 miles.



Photo # 8

TORQUE SPECIFICATIONS

<u>INCH SYSTEM</u>			<u>METRIC SYSTEM</u>		
Bolt Size	Grade 5	Grade 8	Bolt Size	Class 8.8	Class 10.9
5/16	15 FT LB	20 FT LB	6MM	5 FT LB	9 FT LB
3/8	30 FT LB	35 FT LB	8MM	18 FT LB	23 FT LB
7/16	45 FT LB	60 FT LB	10MM	32 FT LB	45 FT LB
1/2	65 FT LB	90 FT LB	12MM	55 FT LB	75 FT LB
9/16	95 FT LB	130 FT LB	14MM	85 FT LB	120 FT LB
5/8	135 FT LB	175 FT LB	16MM	130 FT LB	165 FT LB
3/4	185 FT LB	280 FT LB	18MM	170 FT LB	240 FT LB

- The above specifications are not to be used when the bolt is being installed with a bushing.

Seat Belts Save Lives, Please Wear Your Seat Belt.