

# Jeep Wrangler TJ High Clearance Transfer Case Skid Plate

Kit #: SP28 & (JSRB231A or JSRB2315U)



**Bill of Material:**

**Bill of Material:**

JSRB231A			JSRB2315U		
Part#	Description	Qty	Part#	Description	Qty
TJSRB-1	TJ MAIN SHIFT RELOCATE BRKT	1	TJSRB-1	TJ MAIN SHIFT RELOCATE BRKT	1
TJSRB-2	TJ AUX. SHIFT RELOCATE BRKT	1	TJSRB-2	TJ AUX. SHIFT RELOCATE BRKT	1
516X1FTB	5/16 X 1 FINE THRD BOLT	2	FSB3838	FLANGED SLV BRG 3/8" X 3/8"	2
516FTN	5/16" FINE THRD N/I LOCKNUT	2	SS312-UL	JSRB SLEEVE, .312/.302 LONG	1
38FSFTN	3/8-24 FLANGE SERRATED NUT	2	SS1062-UL	JSRB SLEEVE, 1.062/1.052 LONG	1
516SAEW	5/16 SAE WASHER	2	TS38	EXT.TUBE, 3.25"/FOR JSRB KIT	1
FSB3838	FLANGED SLV BRG 3/8" X 3/8"	2	516X1FTB	5/16 X 1 FINE THRD BOLT	2
TS38	EXT.TUBE, 3.25"/FOR JSRB KIT	1	516FTN	5/16" FINE THRD N/I LOCKNUT	2
			38FSFTN	3/8-24 FLANGE SERRATED NUT	2
			516SAEW	5/16 SAE WASHER	2

**BEFORE YOU BEGIN: WE HAVE MADE CHANGES TO THIS PART NUMBER**

- NOTE: Before beginning installing SP28 skid plate on the factory NP/NV231 transfer case, you MUST have the shifter relocation bracket kit which is either part# JSRB231A for automatic transmission or manual transmission.
- Vehicles equipped with an aftermarket "ATLAS" Transfer case only need the skid plate and therefore DO NOT require the shifter relocation brackets.
- When installing Skyjacker Skid Plate, A Fixed Yoke kit, Skyjacker part #FIX231, will be required for use on vehicles equipped with any size lift kit.
- Skid plate shoe will be required on all manual transmissions. Part# SPS28M
- If you plan to run this skid plate without a transfer case lowering kit, you must install all the accessories listed below in the accessories section of this instruction sheet. These items are required to provide adequate clearance of the floor pan and correct the angles at the coolant fan and rear drive line angle.

**PRE-INSTALLATION NOTES:**

- A professional mechanic is recommended to perform the installation.
- Read the instructions *carefully* and *study* the photo illustrations before attempting the installation.
- Secure and properly block the vehicle on a level concrete or asphalt surface.
- Always wear safety glasses.
- If you have any questions or reservations about this installation, call SKYJACKER® at 318-388-0816.

**ACCESSORIES:** (All required without transfer case lowering kit - see step 4 above)

- Prt.# MM100, 1" motor mount set.
- Fixed Yoke kit prt.# FIX231.
- Rear drive shaft, call Skyjacker Tech Line for applications.
- 1" body lift.

**WARNING: The transfer case and transmission are supported by the transfer case skid plate. Before removing the transfer case skid plate, ensure that the transmission is properly supported.**

**INSTALLATION:**

- Shift transfer case into 4 LOW. Support transmission with a jack and remove all 6 skid plate fastening bolts at frame rails.
- While supporting the skid pan remove the nuts attaching the transmission mount to the skid plate and separate the skid plate from the vehicle.
- NOTE:** If your vehicle is equipped with an automatic transmission, remove and discard the transmission mount support bracket. See *figure #1*.
- If you have an O.E.M. 231 transfer case, identify the items in *figure #3* and begin to dismantle the shifter mechanism. Using a pry-bar or large screwdriver, pry the torque shaft rod from the range lever also pry the shift rod from the transfer case shift lever assemble. Remove and discard the linkage bracket and the torque shaft bracket.

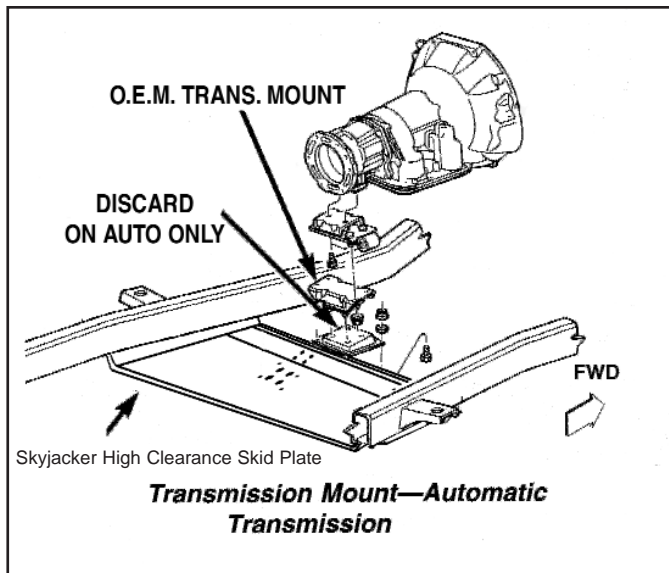

figure #1

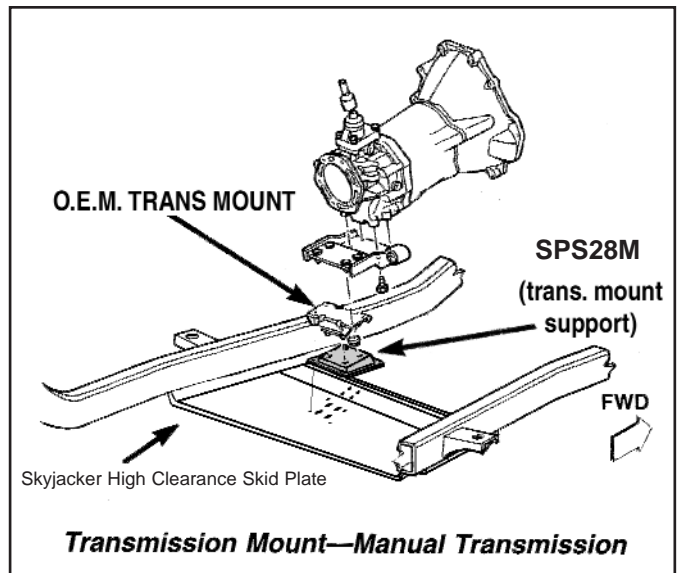

figure #2



figure #4

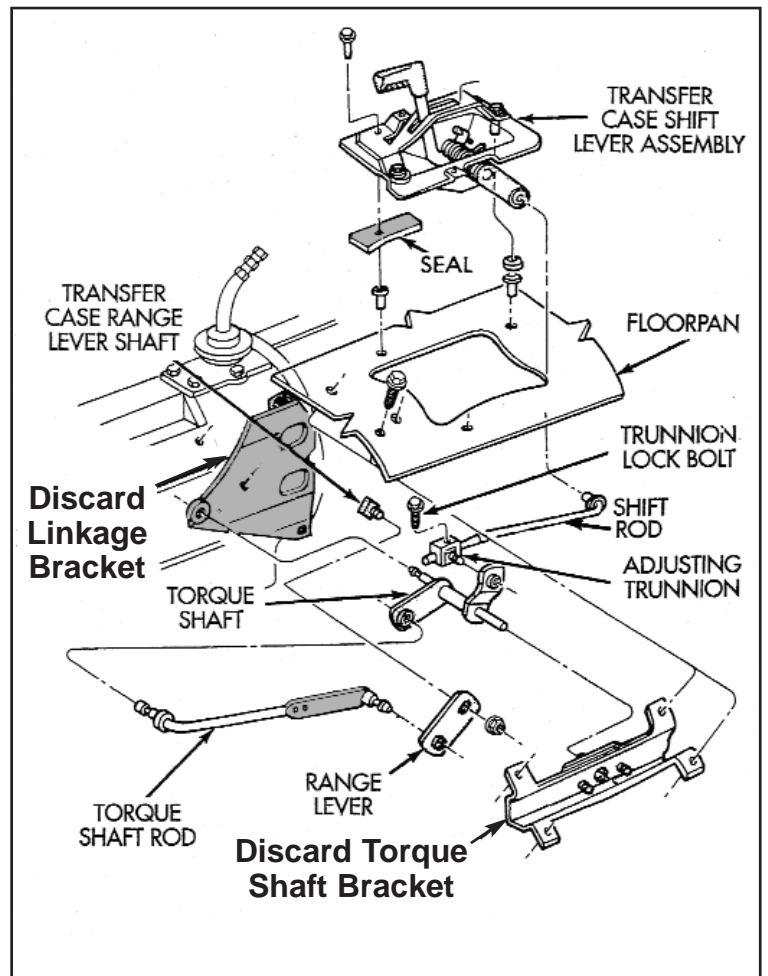

figure #3

Patent Pending

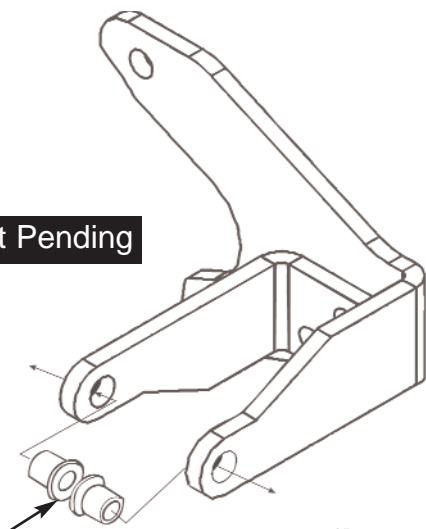

figure #5

**Top-Hat Teflon Bushings**

- Using parts supplied in figure #4, Insert top-hat teflon bushings as shown in figure #5. Assemble the new shift relocating bracket as shown in figure #6.

**Note: On Unlimited Models, the 2 spacers provided must be used as well. See Figure # 6A and 6 B. The Smaller spacer (.312) will be used toward the frame side of the factory bracket. The Larger spacer (1.062) will be used on the transmission side of the factory bracket.**

- With the shifter relocating bracket fully assembled, as in figure #6, cut both ends of the torque shaft flush with the top-hat teflon bushings and discard.

See figure #7 *Jeep Unlimited models will not require cutting.*

- Loosen the trunnion lock bolt at the adjusting trunnion. Install assembled shifter assembly on to the original transfer mounting studs using the factory hardware. Insert the torque shaft rod into the range lever and the shift rod into the transfer case shift lever assembly by using a pair of channel locks. (as shown below)

- If you have a manual transmission install the transmission mount support using the factory hardware to the O.E.M. transmission mount with the thick portion of the mount facing forward. *See figure #2.*

- With transmission still supported, raise skid pan to frame rails and fasten with the supplied 1/2" tapered head allen bolts.

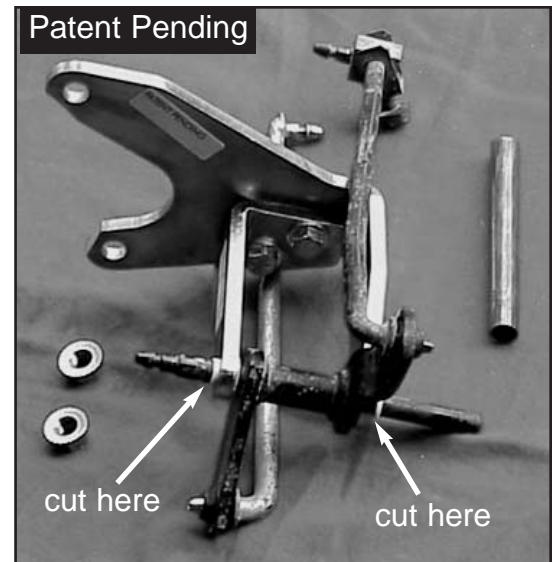

figure #6



figure #6A



figure #6A

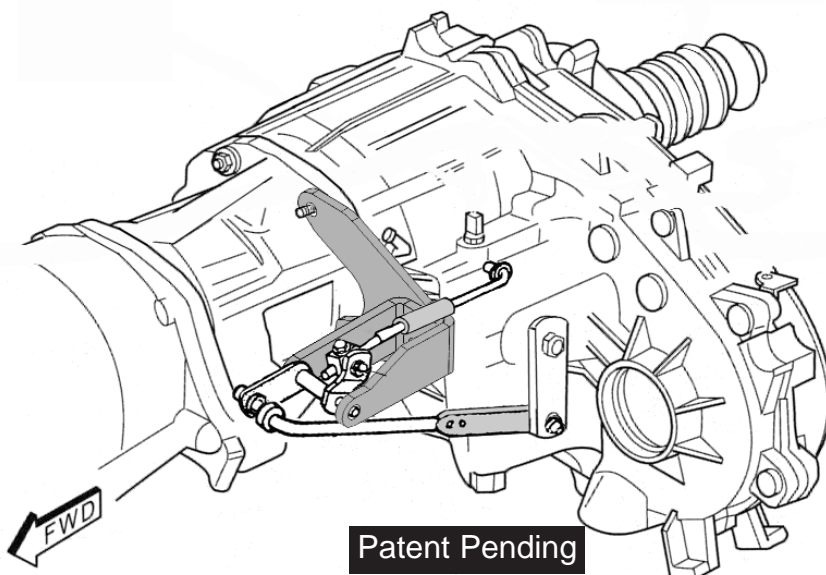

figure #7

10. Position the transmission mount support for manual transmission equipped vehicles into the rear holes of the new skid plate. Using the 5/16" x 1" carriage head bolts, fasten the transmission mount support to the pan. On automatic transmissions position the transmission mount studs through the forward holes and fasten with O.E.M. hardware.
11. Check that transfer case shifter is in 4 LOW and now tighten the trunnion lock bolt into position. Then proceed to check the operation of the shifter.

**POST INSTALLATION NOTE:** After driving the first 50 miles, re-torque **ALL** nuts and bolts then torque again for another 100 miles and then check periodically thereafter.

\* After installation check the operation of the transfer case shifter. Depending on the application, cutting of the shift rod may be necessary. Scribe and cut the shift rod 5 1/2" from the end of the shaft. Insert 3/8" tube spacer, being sure that the scribe marks are in line. Weld to produce the desired shaft length.

Not necessary for Unlimited Models.



figure #8