



www.skyjacker.com

Toyota 4x4 IFS
86-95 Pickup, 86-89 4 Runner
4" Lift Kit
Installation Instructions

REQUIRED TOOL LIST:

- * Metric / Standard Wrenches and Sockets
* Floor Jack
* Jack Stands
* Measuring Tape
* Torque Wrench



1. Before beginning the installation, read these instructions and the enclosed driver's WARNING NOTICE thoroughly and completely. Also affix the WARNING decal in passenger compartment in clear view of all occupants. If any of these items are missing from this instruction packet, do not proceed with installation, but call SKYJACKER to obtain needed items. If you have any questions or reservations about installing this lift kit, call SKYJACKER at 318-388-0816 for Technical Assistance or Customer Service departments.

Make sure you park the vehicle on a level concrete or asphalt surface. Many times a vehicle is uneven (side-to-side) from the factory, but usually not noticed until a lift kit has been installed which makes the difference more visible. Using a measuring tape, measure the front and rear (both sides) from the ground up to the center of the fender opening above the axle. Record below for future reference.

Driver Side Front: _____ Passenger Side Front: _____

Driver Side Rear: _____ Passenger Side Rear: _____

IMPORTANT NOTES:

- Please refer to Parts List to insure that all parts and hardware are received prior to disassembly of vehicle. If any parts are found to be missing, contact your dealer as soon as possible.
• If larger tires (10% more than stock diameter) are installed, speedometer recalibration is necessary (see Toyota dealer or Tire Store).
• Only wheels with no more than 3 3/4" backspacing can be used with this lift.
• After installation occurs, a qualified alignment facility is required to align the vehicle to factory specs.
• After installation occurs, realign headlights to proper position.

Kit Box Breakdown:

T422:

<u>ITEM#</u>	<u>DESCRIPTION</u>	<u>QTY</u>
T4SP-B	TOY 4" SKID PLATE BRACKET	1
401-L	TOY 4" SPINDLE - LEFT	1
401-R	TOY 4" SPINDLE - RIGHT	1
T4FCM-B	TOY 4" FRONT A-ARM CROSS MEMBER	1
T4RCM-B	TOY 4" REAR A-ARM CROSS MEMBER	1
T4DDB-B	TOY 4" DRIVER DIFF DROP BRKT	1
T4CDB-B	TOY 4" CENTER DIFF DROP BRACKET	1
T4PDB-B	TOY 4" PASS DIFF DROP BRACKET	1
T4BP-B	TOY 4" BUMP STOP SPACER BRACKET	4
T4SBL-L	TOY 4" SWAY BAR LWR BRKT-LEFT	1
T4SBL-R	TOY 4" SWAY BAR LWR BRKT-RIGHT	1
BK-T421	BRAKE LINE HARDWARE	1
HB-T421	KIT HARDWARE BAG	1

Hardware Bag Breakdown:

BK-T421 Brakeline Hardware

<u>ITEM#</u>	<u>DESCRIPTION</u>	<u>QTY</u>
TFBE-2	TOYOTA FRONT BRAKE LINE EXTENSION	2
TRBE-1	TOYOTA REAR BRAKE LINE EXTENSION	1
T4RPV-B	TOY 4" REAR PROP. VALVE BRACKET	1
38X1FTB	3/8 X 1 FINE THREAD BOLT	3
516X1FTB	5/16 X 1 FINE THRD BOLT	2
38FTN	3/8-24 FINE N/I LOCK NUT	3
516FTN	5/16-24 FINE N/I LOCK NUT	2
38SAEW	3/8 SAE WASHER	3
516SAEW	5/16 SAE WASHER	2

Hardware Bag Breakdown:

HB-T421

Lift Hardware

<u>ITEM#</u>	<u>DESCRIPTION</u>	<u>QTY</u>
38X2FTB	3/8 X 2 FINE THREAD BOLT, GR8	4
516X1FTB	5/16 X 1 FINE THREAD BOLT	6
12X112FTB	1/2 X 1 1/2 FINE THREAD BOLT	3
12X214FTB	1/2 X 2 1/4 FINE THREAD BOLT	1
12X212FTB	1/2 X 2 1/2 FINE THREAD BOLT	1
58X212FTB	5/8 X 2 1/2 FINE THREAD BOLT	2
58X412FTB	5/8 X 4 1/2 FINE THREAD BOLT	4
38FTN	3/8-24 FINE N/I LOCK NUT	4
516FTN	5/16-24 FINE N/I LOCK NUT	6
12FTN	1/2-20 FINE N/I LOCK NUT	5
58FSFTN	5/8-18 FLANGE STOVER NUT	2
58FTN	5/8-18 NYLON INSERT LOCKNUT	4
38SAEW	3/8 SAE WASHER	11
516SAEW	5/16 SAE WASHER	14
12SAEW	1/2 SAE WASHER	6
TS250	TOY SLEEVE,IFS .250" LONG	1
TS875	TOY SLEEVE,IFS .875" LONG	1
TS1125	TOY SLEEVE,IFS 1.125" LONG	1
TTS34	TOYOTA TAPERED SLEEVE, 3/4"	2
T4LSP	TOY 4" LOCATING SPACER	8
BPBN	BUMP STOPS, BUTTON SHAPE	4
LT100	THREAD LOCK COMPOUND	1

Kit Box Breakdown:

T421R:

<u>ITEM#</u>	<u>DESCRIPTION</u>	<u>QTY</u>
RB35	3.5" REAR BLOCK	2
916X212X1012	1 U-BOLT WITH NUTS	4

Note: T421RS will not consist of lift blocks and the rear U-Bolts will be part # 916x212x7

T431R:

<u>ITEM#</u>	<u>DESCRIPTION</u>	<u>QTY</u>
RB35	3.5" REAR BLOCK	2
916X318X912	1 U-BOLT WITH NUTS	4

Note: T431RS will not consist of lift blocks and the rear U-Bolts will be part # 916x318x812

FRONT :

2. Place floor jack under front axle and raise vehicle. Place jack stands under frame to support vehicle. Set emergency brake and block rear wheels, in front and behind tires. Remove front tires and wheels.
3. Remove clip from front brakeline and bracket. Cut a slot in original brake line bracket (to center of hole) and remove brakeline out of bracket. Install new brakeline drop bracket to OEM bracket and put 3/8" flat washer on top. Insert 3/8 x 1" bolts and washers through both brackets and tighten with 3/8" lock nuts on bottom. You may need to reform line slightly. Be sure not to kink or cause any interference of line. Reinstall OEM brakeline clip to hose at bracket. See Photo #1 and #2. Note: Extended DOT approved stainless steel brakelines are available from Skyjacker. (Part # FBL30)
4. Remove shocks and sway bar plus bump stops on each side (4 bump stops total). Remove eccentric adjustment bolt nuts from front and rear. Remove front cross member from mounting bracket. On **passenger side only**, cut off both existing mounting tabs between the two bolt holes for differential clearance. See Arrow in Photo #3. (Shown after tabs have been cut away).
5. Remove eccentric bolts (front and rear) from the original front lower A-Arms.
6. Install the new front A-Arm drop crossmember assembly into the OEM brackets (See Photo #4). Use new 5/8" x 4 1/2" hex bolts and 5/8" lock nuts, placing the 1 7/8" x 2" locating spacers on the outsides (see arrow in Photo #5) ; torque to 150 ft. lbs. Reinstall OEM eccentric bolts, OEM Cam washers, and nuts at bottom; torque to 103 ft. lbs.

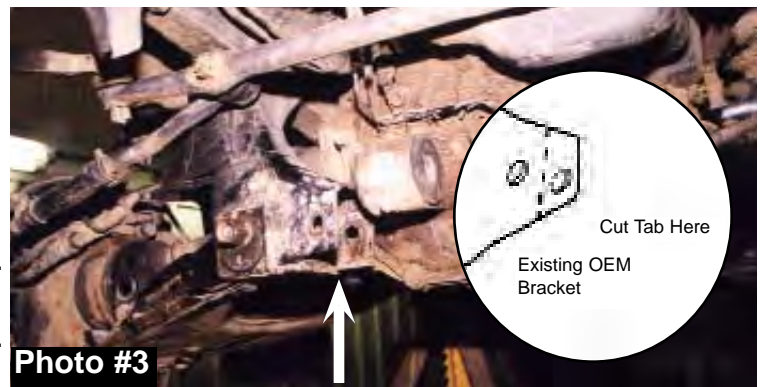
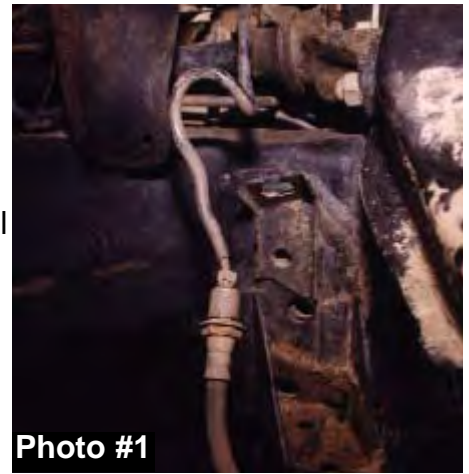

IT422/432



7. Using original bolt and nut, install front differential to new front cross member and tighten. (See Photo #6)



8. Install new rear A-Arm drop crossmember assembly into OEM brackets. (See Photo #7). Use new 5/8" x 4 1/2" hex bolts and 5/8" lock nuts, placing the 1 7/8" x 2" locating spacers on the outsides (See arrow in Photo #8); torque to 150 Ft. Lbs. Reinstall OEM eccentric bolts with hole in OEM Cam washer at bottom; torque to 103 Ft. Lbs. **Note:** under differential insert a 3/8" x 2" bolt and washer through hole in new rear cross member assembly (See Arrow in Photo #8). Do not install nut at this time; there will be room to install later.



9. Lower differential being careful not to pull out front driveshaft. Install new center differential as shown in Photo #9. (A) Install the 1/4" spacer tube at rear lower mounting between differential and bracket. Install existing OEM bolts through bracket, spacer and into the two bottom holes (use loctite), and torque to 70 Ft. Lbs. (B) Install 1 1/8" spacer tube at rear of upper OEM rubber mount with 1/2" x 2 1/2" hex bolt, 1/2" flat washer and lock nut. (C) Install 7/8" spacer tube at rear of upper OEM rubber mount with 1/2" x 2 1/4" bolt, 1/2" flat washer and 1/2" lock nut. Torque 1/2" bolts to 85 Ft. Lbs.

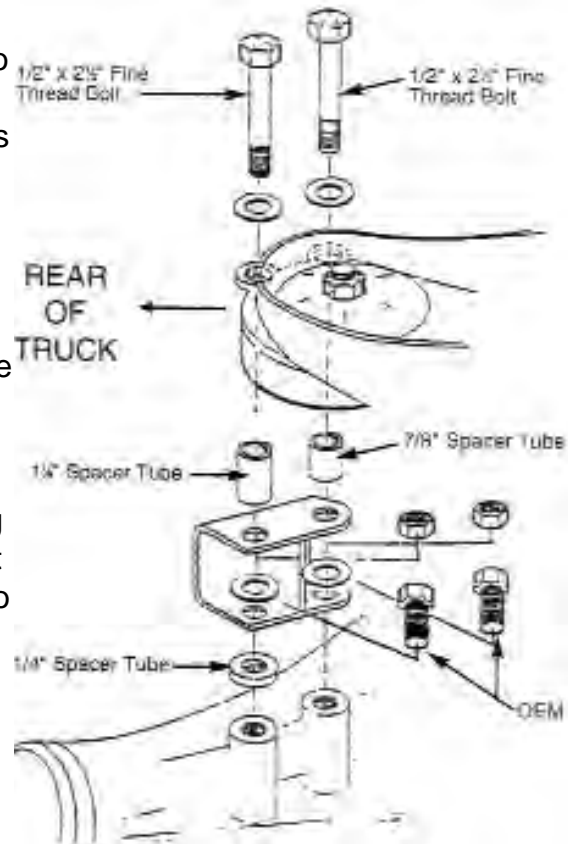

10. Install passenger side differential drop bracket using 1/2" x 1 1/2" hex bolt with two 1/2" flat washers and lock nut into upper hole of OEM rubber mount. Install bottom using original bolt and washer (wide part of bracket should be at bottom with hole towards front). Apply loctite and tighten to 70 Ft. Lbs. (See Photo #10).

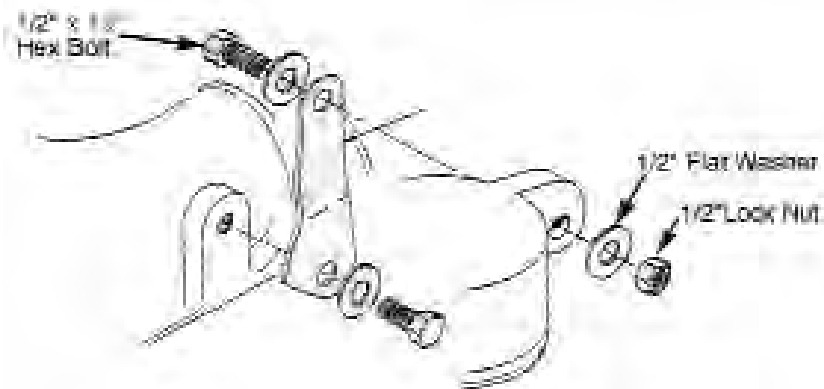

Photo #9

Photo #10

11. Install driver side differential drop bracket using OEM bolts in two bottom holes. Apply loctite and torque to 70 Ft. Lbs. Use 1/2" x 1 1/2" hex bolts, washers, and lock nuts in two upper holes. Torque to 85 Ft. Lbs. (See Photo #11).
12. Remove tie rods from steering knuckles. Remove two bolts on back side (inside) of spindle which hold the metal bracket for the brake hose.
13. Support lower A-Arms with floor jack and separate upper ball joint from spindle. Using file, file corners off OEM spindle to contour with bottom of new spindle adapter so that the bottom of the new spindle seat surface is in contour with OEM spindle top surface. Clean out hole on top of steering knuckle (spindle).



Photo #11

14. As shown in Photo #12, insert tapered spindle sleeves with small end downward. Be sure tapered sleeves are flush with top of spindle (if necessary tap with a hammer, or file down to be flush). Place new spindle adapters onto original spindles, and install 5/8" x 2 1/2" hex bolts and 5/8" flanged stover lock nuts. **Note: Be sure to use the special black Grade 8 Flanged Stover Lock Nut supplied!** Torque to 150 Ft. Lbs. Insert upper ball joints into new spindle adapters and torque to 105 Ft. Lbs.

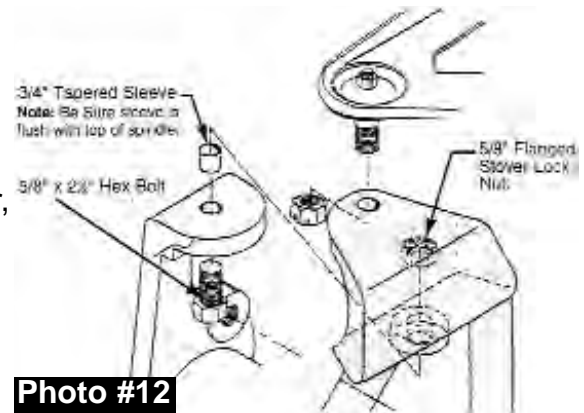

Photo #12

Reinstall tie rods, and torque to 67 Ft. Lbs. Next reinstall brake hose brackets to bottom of new spindle adapters using OEM bolts (apply loctite). Be sure to install cotter pins.

15. Slightly file original bump stop mounting lips on each side (only the front two) for shock clearance. Install new Skyjacker shocks.
16. Attach new polyurethane bump bump stops to new bump stop spacers. Then install bump stop spacers to original mounts with 3/8" coarse thread lock nuts. See Photo #13.



Photo #13

17. Install the two new sway bar drop down brackets to frame using OEM hardware, but adding a 5/16" flat washer under bolt heads. Install sway bar to bottom of new drop down brackets using new 5/16" x 1" bolts, 5/16" flat washers (1 under bolt heads and 1 under nuts) and 5/16" lock nuts. Torque all bolts to 25 Ft. Lbs. See Photo's #14 and #15 (open side goes inward with slant down and toward the front). Tighten A-Arm end of sway bar.



Photo #14

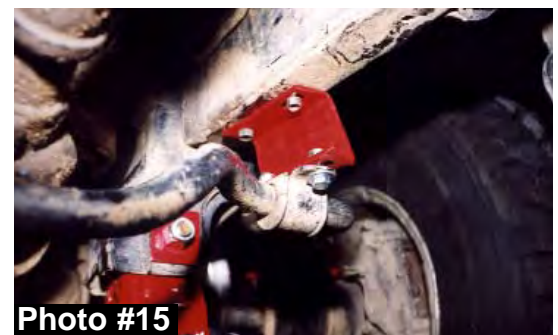

Photo #15

18. Install new lower skid plate to both new front and rear A-Arms crossmember assemblies using 3/8" x 2" bolts, 3/8" washers (one under each bolt head, and 1 under each nut), and 3/8" lock nuts. Install as shown with bolt head underneath skid plate, except on the rear at passenger side, bolt was installed in step #8 from top of cross member down through the skid plate (install washer and nut underneath skid plate). Torque bolts to 37 Ft. Lbs. (See Photo #16).



Photo #16

19. If equipped with original front skid plate, reattach it to front frame mounts using original hardware. Attach bottom of OEM skid plate to front holes in new lower skid plate using 5/16" x 1" bolts with 5/16" washers (1 under each bolt head, and 1 under each nut), and 5/16" lock nuts. Tighten upper frame bolts. Next tighten bottom bolts, being careful not to crush OEM mounting tabs. See Photo #17



Photo #17

20. Install the front tires and lower vehicle to ground.

REAR:

21. Place floor jack under rear axle and raise vehicle. Place jack stands under frame to support vehicle. Set emergency brake and block front wheels, in front and behind tires. Remove wheels and shocks.

22. Cut OEM bracket to center of hole to remove brakeline/clip from bracket (See arrow in Photo #18). Attach rear brake line drop down bracket to existing bracket using 3/8" x 1" hex bolt, 3/8" flat washers and 3/8" lock nut. Torque to 37 Ft. Lbs. Install brake line into lower bracket hole and reinstall OEM brake line clip. **Note: Extended DOT approved braided stainless steel hoses are available from Skyjacker. (Part #RBL30)**

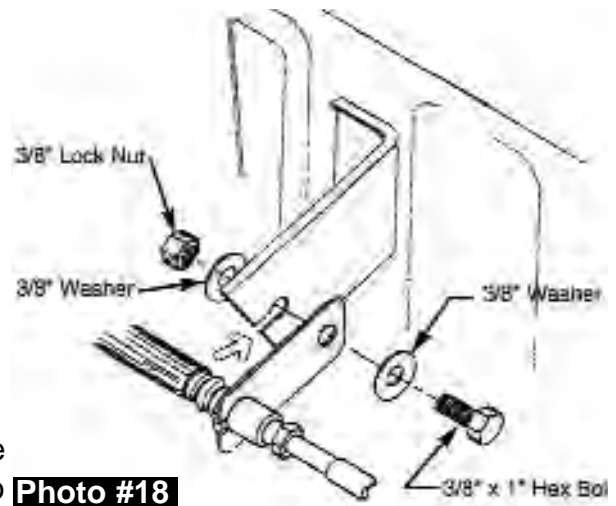

Photo #18

23. Unbolt brake equalizer arm bracket from axle. Install new rear brake cable extension bracket to original axle mount with OEM hardware. Mount equalizer bracket to top of new extension bracket using 5/16" x 1" hex bolts with locknuts. Torque to 20 Ft. Lbs. (See Photo #19)

24. Loosen emergency brake cables by removing cotter pin, pulling pin out from back side of brake backing plate at adjuster.

25. Remove the axle U-Bolts and lower axle down a few inches. Care should be taken because when U-Bolts are removed, axle can move freely.

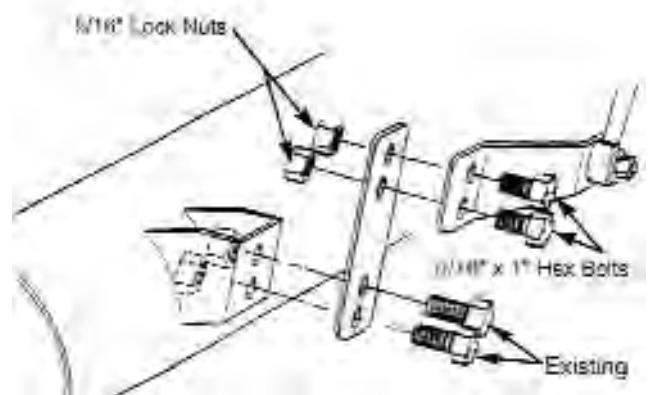

Photo #19

If installing a Softride "System" w/ new Rear Springs, Skip To Step # 28.

26. **Block Installation:** Place the rear lift blocks in position on the axle making sure the pin in the block is in the hole of the axle housing. Note: The short end of the block goes toward the front of the vehicle so that the pinion will be rolled upward toward transfer case.
27. Raise the axle housing up until the pins in the spring aligns and seats in the holes in the blocks.
28. **New Spring Installation:** Remove the spring eye bolts and remove original springs from vehicle. Install the new SOFTRIDE springs into original mounts.
29. Raise the axle housing up until the pins in the spring aligns and seats into the mounting pad on the axle. Reinstall emergency brake cable, keeping cable under spring.
30. Re-mount the axle to the springs using the existing spring plates and the new U-Bolts using the nylon lock nuts. Torque U-Bolts to only 85-90 Ft. Lbs.
31. Install new rear Skyjacker Shocks, and tires then lower vehicle to the ground.

Notes:

- * **Check front drive shaft at lower half of clamshell to assure proper clearance, and grind if necessary. (See Arrow in Photo #20).**
- * After installation is completed, double check that all nuts and bolts are tight. (Do not retighten nuts where loctite was used).
- * After driving the first 50 miles, retorque all nuts and especially bolts, torque again after another 100 miles and periodically thereafter.
- * Measure from center of Eccentric adjuster bolt to the ground to ensure proper ride height.
- * During alignment, the inner and outer tie rod ends on each side may need to be pulled out of adjusting sleeve and cut 1/2" off tie rod ends so proper adjustment can be achieved.
- * When installing larger tires and wheels, check for clearance of upper A-Arm.



Photo #20

Torques	A-Arm Drop Bracket Bolts.....	100' Lbs.	Specifications:
	Crossmember Bolts.....	45' Lbs.	
	Eccentric Bolts.....	103' Lbs.	
	Inner Differential Bolts.....	70' Lbs.	
	Passenger Differential Bolts.....	70' Lbs.	
	Driver Differential Bolts.....	70' Lbs.	
	Tapered Spindle Sleeve Bolt.....	100' Lbs.	
	Spindle to Upper Ball Joint.....	105' Lbs.	
	Tie Rod Ends.....	67' Lbs.	
	U-Bolts.....	85-90' Lbs.	

Seat Belts Save Lives, Please Wear Your Seat Belt.