



THE NEXT GENERATION OF FOLDING TONNEAU COVERS.

Model Specific Install Guide

GM Applications

Chevy Silverado / GMC Sierra 2007-2013
With Cargo Management System - With factory bed rail caps
5.7' Bed - FX11016
6.5' Bed - FX11017

1 Hardware Kit Check List

- A. Clamp kit (6)
- B. Rubber Filler Strips(6)
- C. Star Knobs(2)
- D. Front Retainer Clamps(2)
- E. Front Mounting Bolts (2) Lock Washer (2), Flat Washer (2)

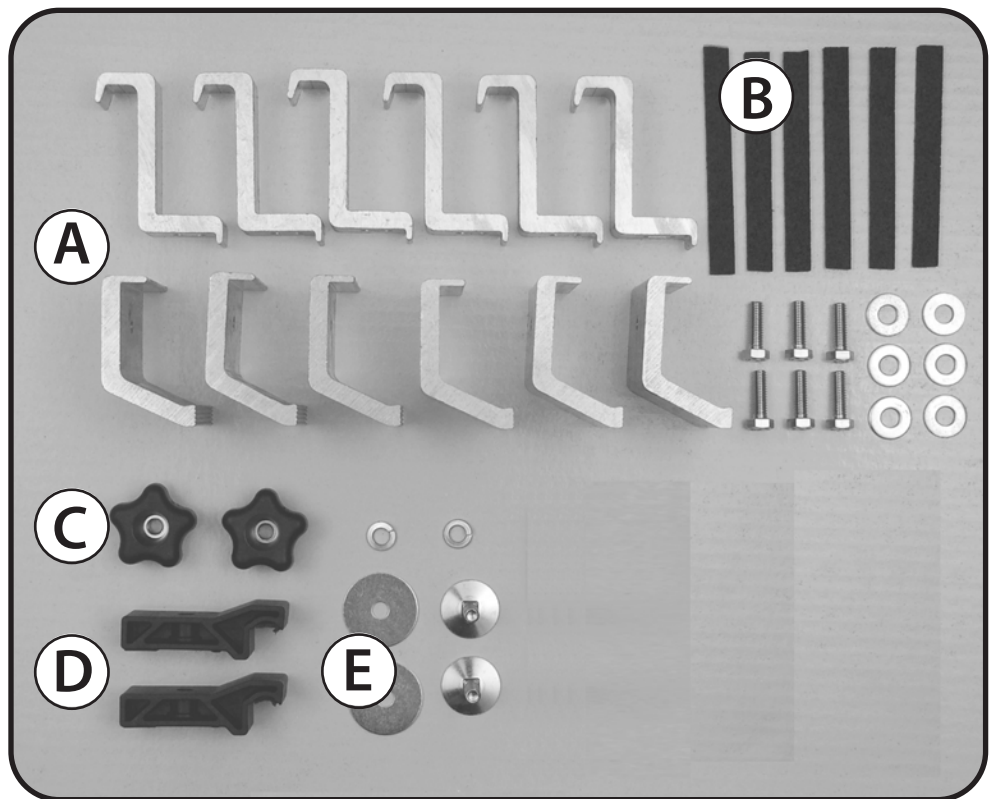

KIT - Q



2 Attach Side Mounting Rails

Stick each one of the rubber filler strips to the bed rail, adjacent to each rail spacer (black piece with clamp written on it), prior to installing the mounting rail. *Tip* : Lay the cover mounting rail on top of the truck bed rail, drain tube towards the cab, to help indicate position of the filler strips. The filler strips should be mounted on the lower portion of the bed rail, Figure 1.

Attach both left and right side rails to the truck bed. The end of the mounting rail with the drain tube fitting will go towards the cab of the truck.

Position the top edge of the mounting rail flush to 1/8" above the top edge of your truck bed rail, Figure 1 & 2. Using three (3) clamps per side attach the rail to the bed, position the clamps adjacent to each of the black rail spacers. (*Tip*: Mount the center clamp first but do not tighten completely. This will give you the ability to adjust the rail as the outer clamps are attached) Tighten the clamps using a 1/2" wrench or socket, Photo A.

Note: If you discover your truck will not allow you to position a clamp adjacent to the spacer, simply slide the spacer forward or back as needed.



Warning! Do not overtighten the clamp assembly. A torque wrench is not necessary. If preferred, torque is apx 120 inch lbs.



Warning! Clamps must be checked periodically for tightness. Failure to do so could result in damage to you or your property.

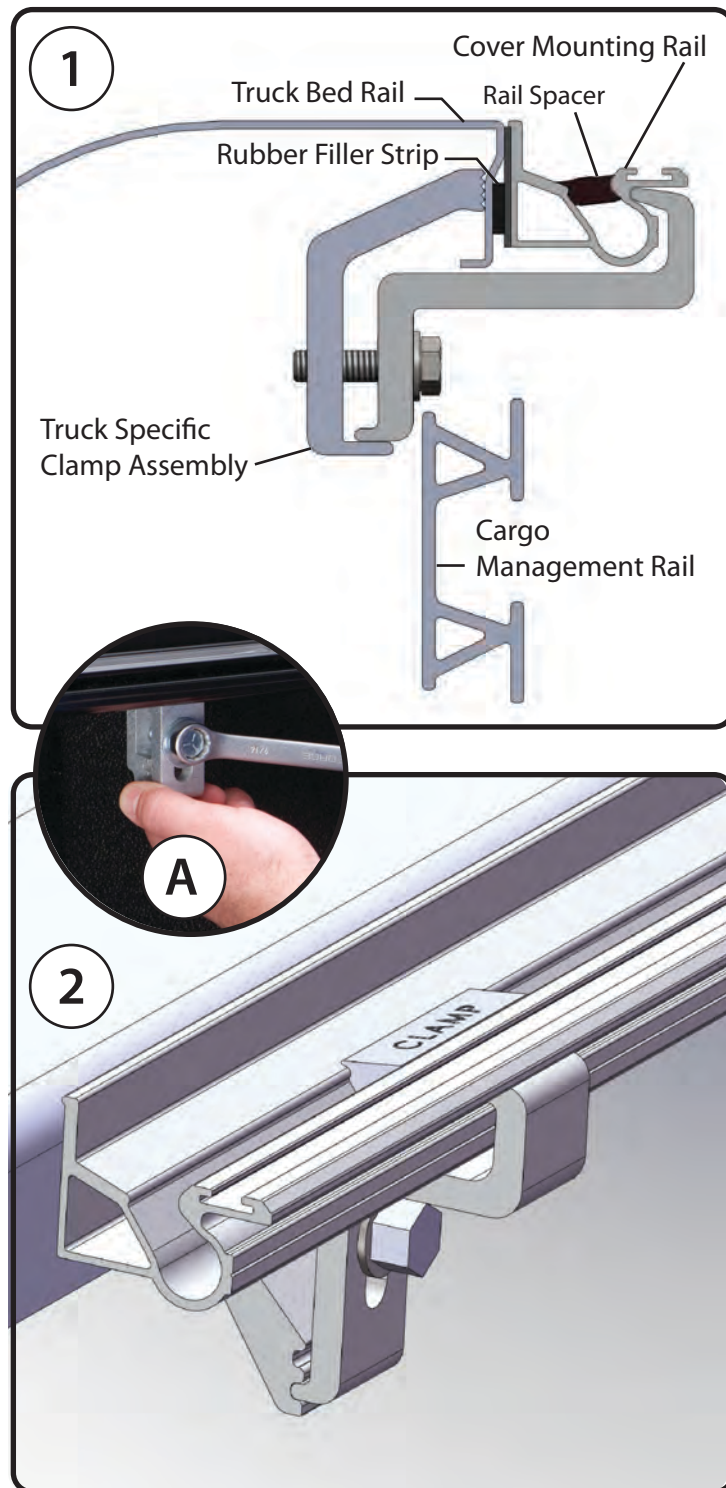

UnderCover, Inc.
P.O. Box 620
Rogersville, MO 65742
(417) 753-8000
(866) 900-8800

www.undercoverinfo.com
sales@undercoverinfo.com