



# Installation Instructions

## Manual Locking Hub KIT

P/N 29070 and P/N 29071

As you read these instructions, you will see **NOTES**, **CAUTIONS** and **WARNINGS**. Each message has a specific purpose. **NOTES** are additional information to help you complete a procedure. **CAUTIONS** are safety messages that indicate a potentially hazardous situation which, if not avoided, may result in minor or moderate injury. A **CAUTION** may also be used to alert against unsafe practice. **WARNINGS** are safety messages that indicate a potentially hazardous situation, which, if not avoided could result in serious injury. **CAUTIONS** and **WARNINGS** identify the hazard, indicate how to avoid the hazard, and advise of the probable consequence of not avoiding the hazard. **PLEASE WORK SAFELY!**

**WARN INDUSTRIES, INC. □ 12900 SE CAPPS ROAD □ CLACKAMAS, OR 97015-8903**  
**(503) 722-1200 □ CUSTOMER SERVICE LINE 1-800-543-WARN**  
**FAX (503) 722-3000**

### SAFETY PRECAUTIONS



#### CAUTION



#### Read instructions thoroughly before beginning installation.

This sheet provides guidelines to install the WARN Spindle Nut Kit. There are **NOTES**, **CAUTIONS**, and **WARNINGS** which should be followed during installation to avoid possibility of personal injury or damage to the vehicle. During installation, standard safety precautions and equipment should be used where appropriate. Because the skill and experience of the installer and the tools used can vary widely, it is impossible to anticipate all conditions under which this installation is made or to provide cautions for all possible hazards. If your installation varies from the instruction, you must be completely satisfied that your safety or the operation of the vehicle will not be compromised.

### APPLICATIONS

This kit (WARN P/N 29070) installs manual locking hubs on the following vehicle(s).  
1983 to 1989 Ford Bronco II, Ranger

This kit (WARN P/N 29071) installs manual locking hubs on the following vehicle(s).  
1990 to 1997 Ford Ranger  
1990 to 1994 Ford Explorer

### PARTS LIST

Manual Hublock (2x)

### TOOLS NEEDED

Blade Screw Driver  
Lug Wrench  
50-250 ft-lb Torque Wrench

**Figure 1: Remove Manual Locking Hubs.**

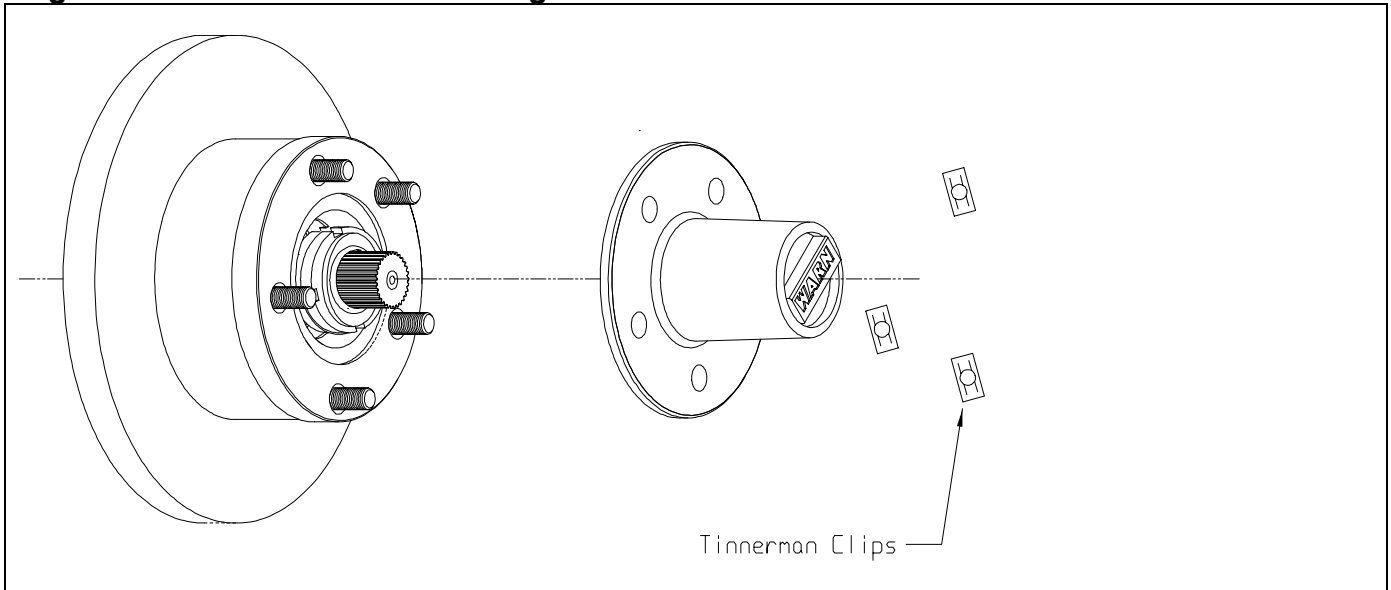

**Figure 2: Remove Automatic Locking Hubs.**

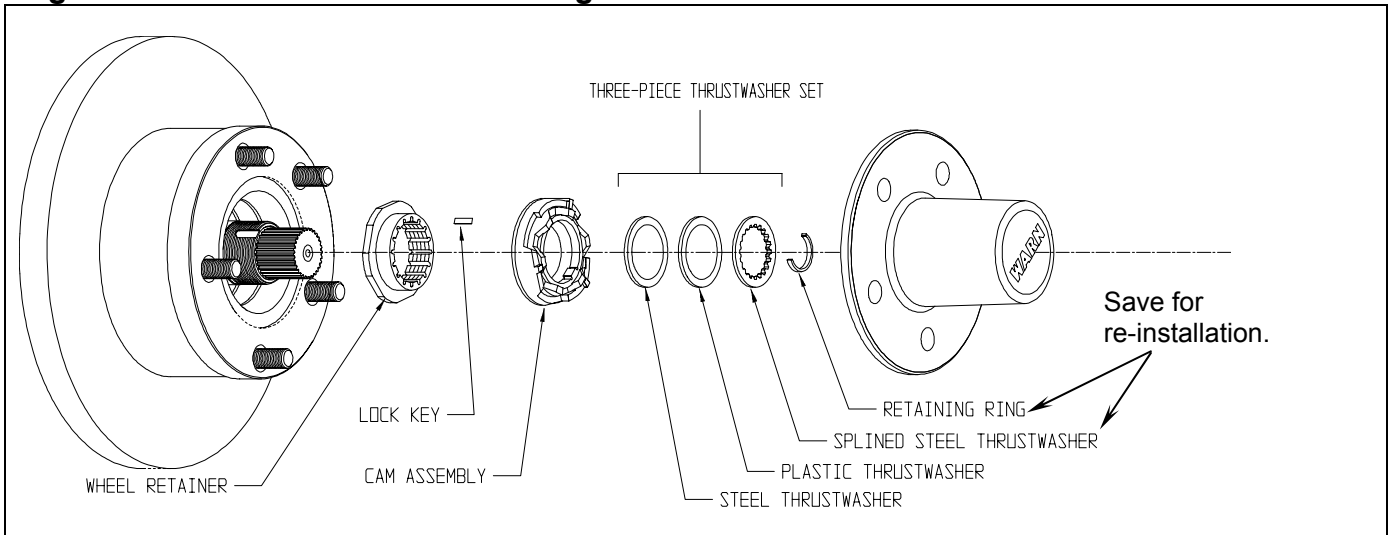

**Figure 3: Remove Automatic Locking Hubs.**

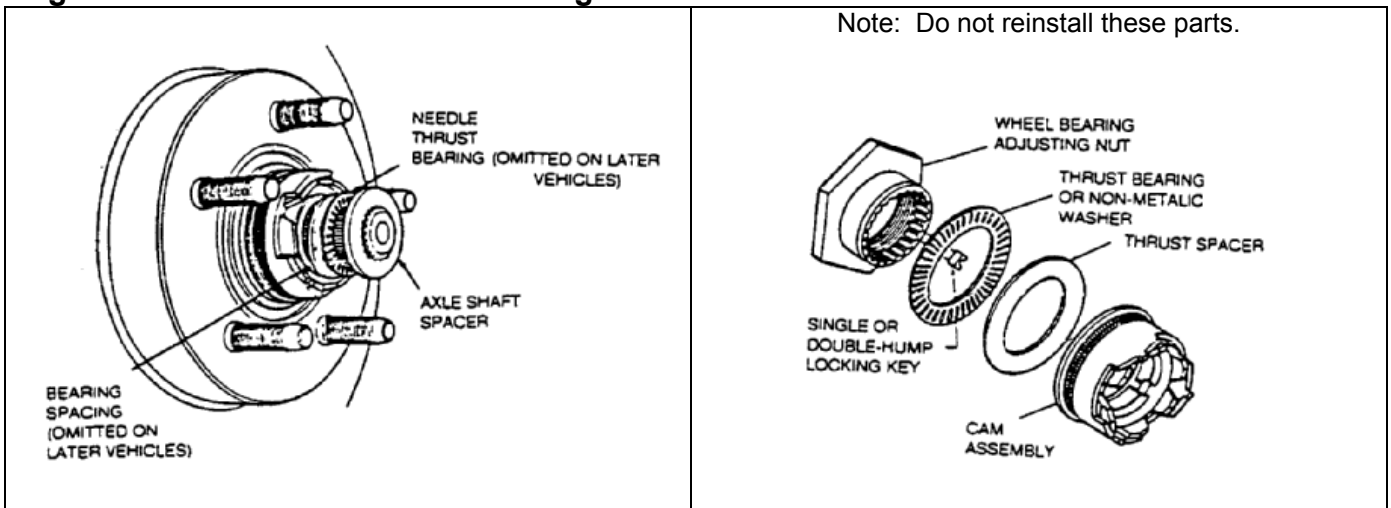

## **Preparation:**

1. Turn the ignition key OFF. Put transmission in Park (automatic) or Reverse (manual).
2. Set the parking brake and block the rear wheels.

## **Removing Manual Hubs:**

Remove the Tinnerman Clips that are securing the hublock assembly to the wheel studs. See figure 1. Remove the hublock assembly from the hub and rotor assembly.

## **Removing Automatic Hubs:**

If you are replacing automatic locking hubs you will also need to replace the wheel bearing adjusting nuts. Your local Ford dealer can supply the adjusting nuts and washers for use with manual locking hubs. Warn Industries offers spindle nut conversion kits specifically designed to replace the wheel bearing adjusting nuts and work with manual locking hubs. Warn's Spindle Nut Conversion Kits are:

1983 through very early 1990 vehicles with 23 tooth axle spline.....Warn P/N 27988  
Early 1990 and later vehicles with 27 tooth axle spline.....Warn P/N 32720

1. Remove the Tinnerman Clips that are securing the hublock assembly to the wheel studs. See figure 1.
2. Remove the hublock assembly from the hub and rotor assembly.
3. Remove the axle shaft retaining ring, splined steel thrustwasher, needle thrust bearing (on earlier vehicles), and steel thrustwasher.
4. Remove the cam assembly, thrust spacer and thrust bearing or thrust washers from the wheel bearing adjusting nut. See figure 2 and 3.
5. Remove the single or double hump locking key from the wheel bearing adjusting nut. Use a small pick to locate and extract the locking key. Note: Be sure the adjusting nut is not binding against the locking key. Any binding may make removal of the key very difficult.
6. Remove the wheel bearing adjusting nut.

## **Installing Manual Locking Hubs:**

1. If replacing automatic locking hubs with manual locking hubs reinstall the axle shaft splined steel washer or needle thrust bearing and the axle retaining ring.
2. Install the Hublock assembly against the wheel hub and rotor.
3. Install the wheel and tire and torque the lug nuts to 85 to 135 ft-lb.

## MANUAL HUB OPERATING INSTRUCTIONS:

### 2WD Operation:

Set both control dials at "FREE" and the transfer case selector at 2WD for free wheeling two wheel drive. Use the "FREE" position for all driving that does not require four wheel traction.

### 4WD Operation:

To engage four wheel drive, set both hub control dials at "LOCK" move the transfer case selector to 4WD. Do not drive on hard surface roads in this mode. It can result in severe torque wind-up in the gear-train. Return the transfer case to 2WD before unlocking the hubs.

## SAFETY PRECAUTIONS



### CAUTION



**Do not move the vehicle if the control dials are anywhere between "FREE" and "LOCK".** To do so may cause hub damage.

**Do not move the vehicle with only one hub engaged.** To do so can cause damage to the front differential.

**Do not move the vehicle with the hubs in the "FREE" position and the transfer case in low range.** To do so may damage the rear drive train.

**Engage both hub locks and drive for a minimum of one mile each month to insure lubrication of the front axle.**



GO PREPARED.

Warn Industries, Inc. (WARN) warrants to the original purchaser that the mechanical components of the "WARN" Locking Hub will be free of defects in material and workmanship for the lifetime of the hub. This Warranty applies only to the original purchaser of the hub. To obtain any warranty service, you must provide WARN with proof of purchase and date of purchase acceptable to WARN, such as a copy of your purchase receipt. This warranty does not cover the removal or reinstallation of the hub. WARN will, at its option, repair, replace or refund the purchase price of a defective hub or component, provided you return the defective hub or component during the warranty period, transportation charges prepaid, to Warn Industries' Service Department or a Factory Authorized Service Center. Attach your name, address, telephone number, a description of the problem, and a copy of your receipt and original bill of sale of the defective hub and date of purchase.

**This warranty does not apply (i) to finish, or (ii) if the hub has been damaged by accident, abuse, misuse, collision, overloading, modification, misapplication, improper installation, or improper service. Commercial or industrial use or application voids the warranty.**

**THE WARRANTY SET FORTH ABOVE IS THE ONLY WARRANTY. THERE ARE NO OTHER WARRANTIES, EXPRESS OR IMPLIED, INCLUDING BUT NOT LIMITED TO IMPLIED WARRANTIES OF MERCHANTABILITY OR FITNESS FOR A PARTICULAR PURPOSE.**

**ANY IMPLIED WARRANTY WHICH BY LAW MAY NOT BE EXCLUDED IS LIMITED IN DURATION TO ONE (1) YEAR FROM THE DATE OF ORIGINAL RETAIL PURCHASE OF THE PRODUCT.**

WARN SHALL NOT BE LIABLE FOR SPECIAL, INDIRECT, INCIDENTAL OR CONSEQUENTIAL DAMAGES (INCLUDING, BUT NOT LIMITED TO, LOST PROFITS, DOWN TIME OR LOSS OF USE) UNDER ANY LEGAL THEORY, EVEN IF WARN WAS ADVISED OF THE POSSIBILITY OF SUCH DAMAGES.

Some states do not allow the exclusion of implied warranties or the exclusion or limitation of liability for incidental or consequential damages, or limitations on how long an implied warranty lasts, so the above limitation or exclusion may not apply to you. This warranty gives you specific legal rights. You may also have other rights that vary from state to state.

WARN reserves the right to change Product design without notice. In situations in which WARN has changed a Product design, WARN shall have no obligation to upgrade or otherwise modify previously manufactured Products.

**No WARN dealer, agent or employee is authorized to make any modification, extension or addition to this warranty.**

Warranty inquires and Products returned for warranty service should be sent to:

**WARN INDUSTRIES, INC**

Customer Service Department

12900 SE Capps Road

Clackamas, OR 97015

1-800-543-WARN (1-800-543-9276)

1-503-722-3005 International Fax

**Products Covered By this Warranty**

Locking Hubs

**Products Not Covered by this Warranty**

Finish to Locking Hubs