



## INSTALLATION INSTRUCTIONS

Trans4mer Mounting System  
Toyota Tacoma Kit No. 32522(black) or  
32523(chrome)

### PARTS LIST

PART NO.	QUANTITY	DESCRIPTION
32503	1	FRAME EXTENSION, R.H.
32504	1	FRAME EXTENSION, L.H.
32501	2	SIDE MEMBER, BLACK
32502	2	SIDE MEMBER, CHROME
32507	1	BRACE, R.H.
32508	1	BRACE, L.H.
29398	1	1-1/2" TUBE, CHROME
29365	1	1-1/2" TUBE, BLACK
29399	1	2-1/2" TUBE, CHROME
29366	1	2-1/2" TUBE, BLACK

### TORQUE SPECIFICATIONS

3/8 INCH	30 lb. ft. (40.7 N-M)
7/16 INCH	50 lb. ft. (67.8 N-M)
12mm	75 lb. ft. (101.7 N-M)

**Note: Do not securely tighten any fasteners until directed later.**

This **WARN Trans4mer system** can be customized to give your Toyota Tacoma pickup a wide variety of looks, front end protection and winch mounting capability. The system starts with this strong two-tube grille guard that attaches to the truck's frame with brackets designed by Warn engineers to handle up to a 9000 lb winch. It is durable and good looking, even as a stand alone grill guard, but can be easily upgraded with some great options! You can add a third large size tube (light bar) that adds even more protection and includes tabs for mounting auxiliary lights. The tubes can be mounted in a variety of positions to achieved the look and function that you desire. You can mount a Warn carrier bracket that provides a permanent mount for a Warn winch. You may also add a receiver bracket that will handle the Warn Multi-mount winch system, a draw bar or any other accessory that fits the standard 2 inch receiver tube. Finally, brush guards that protect the headlights and front

corners of the truck that can be easily added to any of the options above.

### WARN PART NUMBERS FOR AVAILABLE OPTIONS

Light Bar Kit, (Black)	29395
Light Bar Kit (Chrome)	29396
Winch Carrier Kit (argent color matches winch)	29394
Receiver Kit (Black only)	29397
Brush Guard Kit (Black)	32525
Brush Guard Kit (Chrome)	32526

**NOTE: Please read these instructions thoroughly before starting the installation of this kit.**

Minor modifications may be required due to variations between vehicles.

1. Refer to **Figure 1** and cut slots into the plastic panel below the front bumper in the locations shown. The plastic can easily be drilled, sawed or cut with any sharp cutting tool.

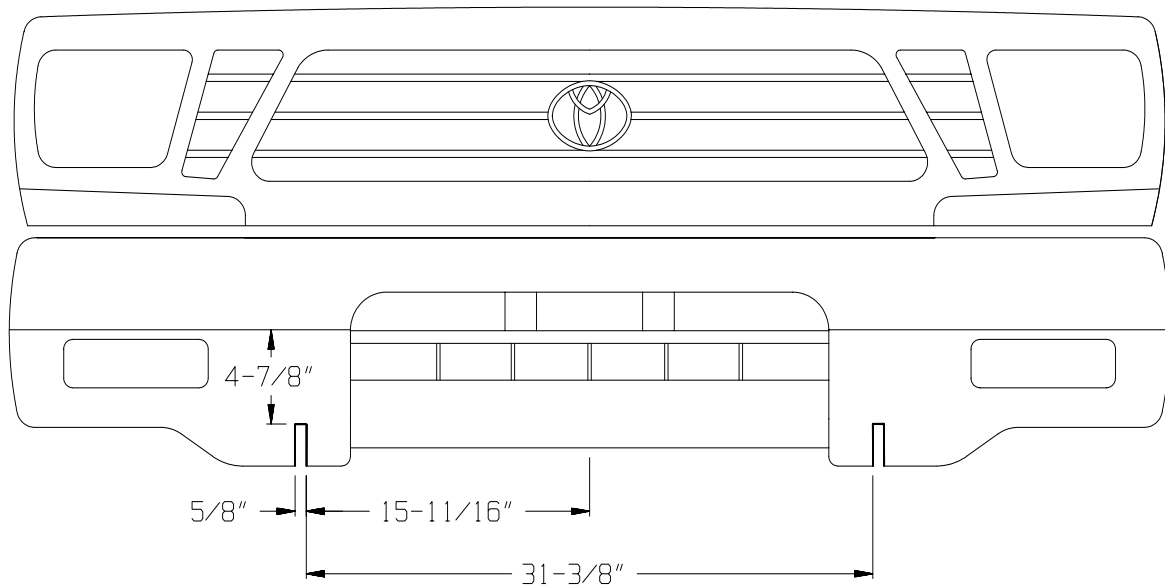

**FIGURE 1**

2. Remove the factory tow hook and tie down loops from the bottom of the vehicle frame. Install the frame extensions onto the bottom of the frame as shown in **Figure 2**.

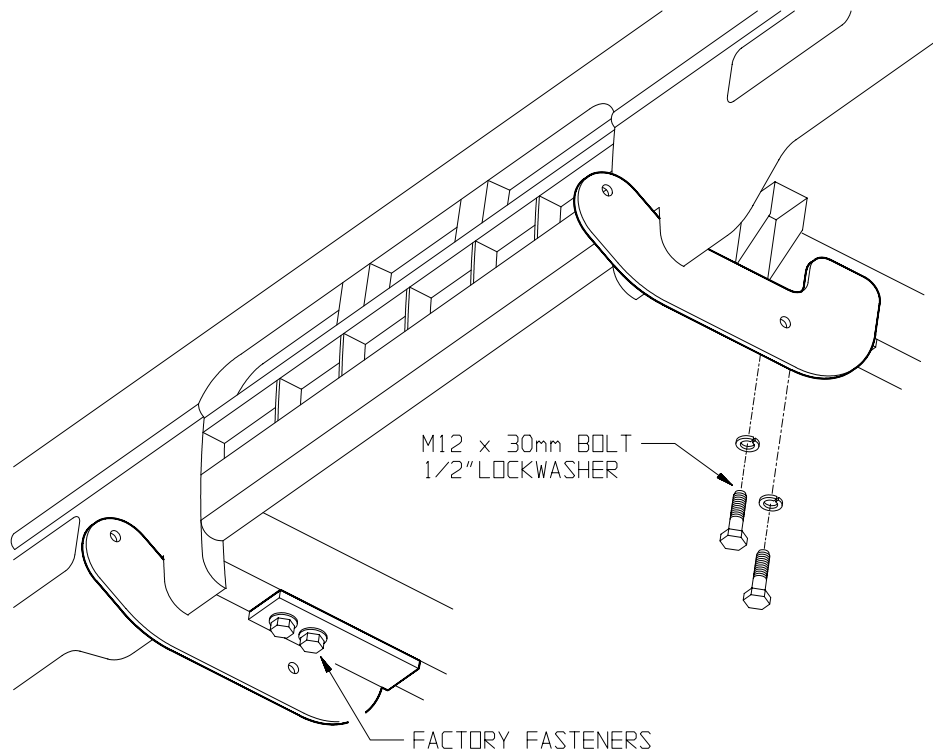
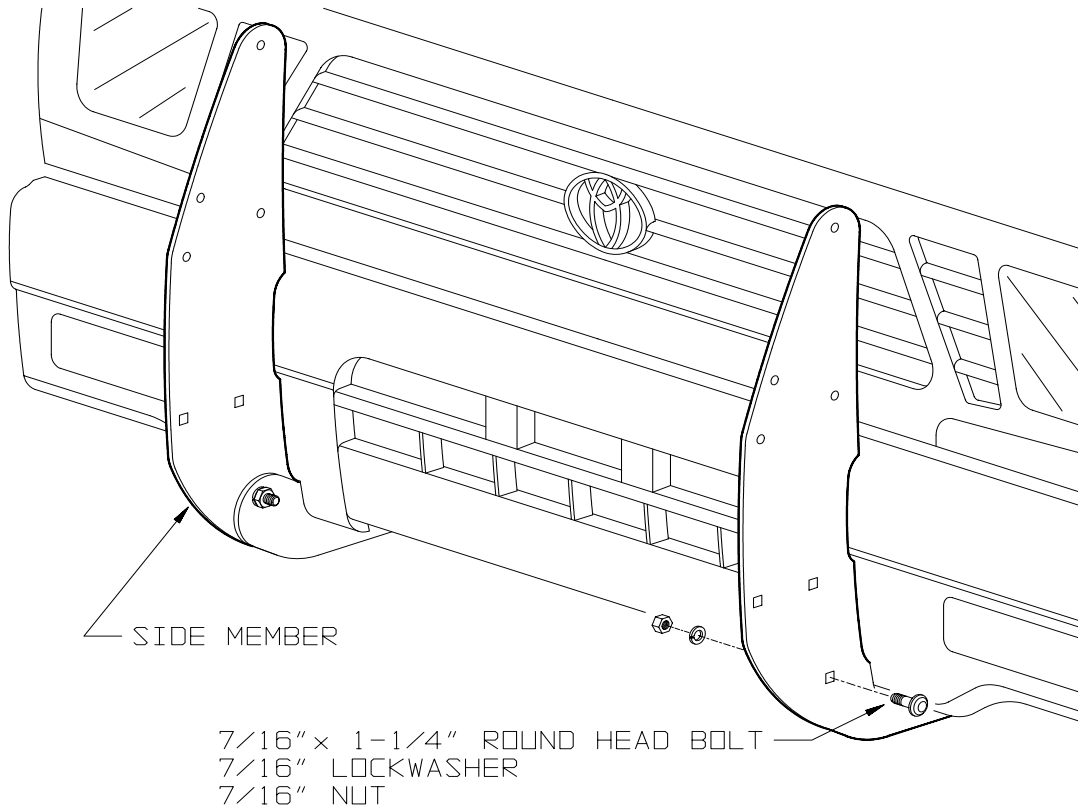

**FIGURE 2**

3. Install the side members onto the outsides of the frame extensions as shown in **Figure 3**.

**NOTE:** If brush guards are being installed, refer to those instructions now and get them in place before tightening the side member bolts.

**FIGURE 3**



4. If the Trans4mer is being installed as a grille guard and a winch is not being mounted at this time, install the tubes in any desired position as shown in **Figure 4**. If the Winch Carrier or Receiver Kit is being added, install a tube only in the top position and then refer to the specific instructions packaged with those items.

**FIGURE 4**

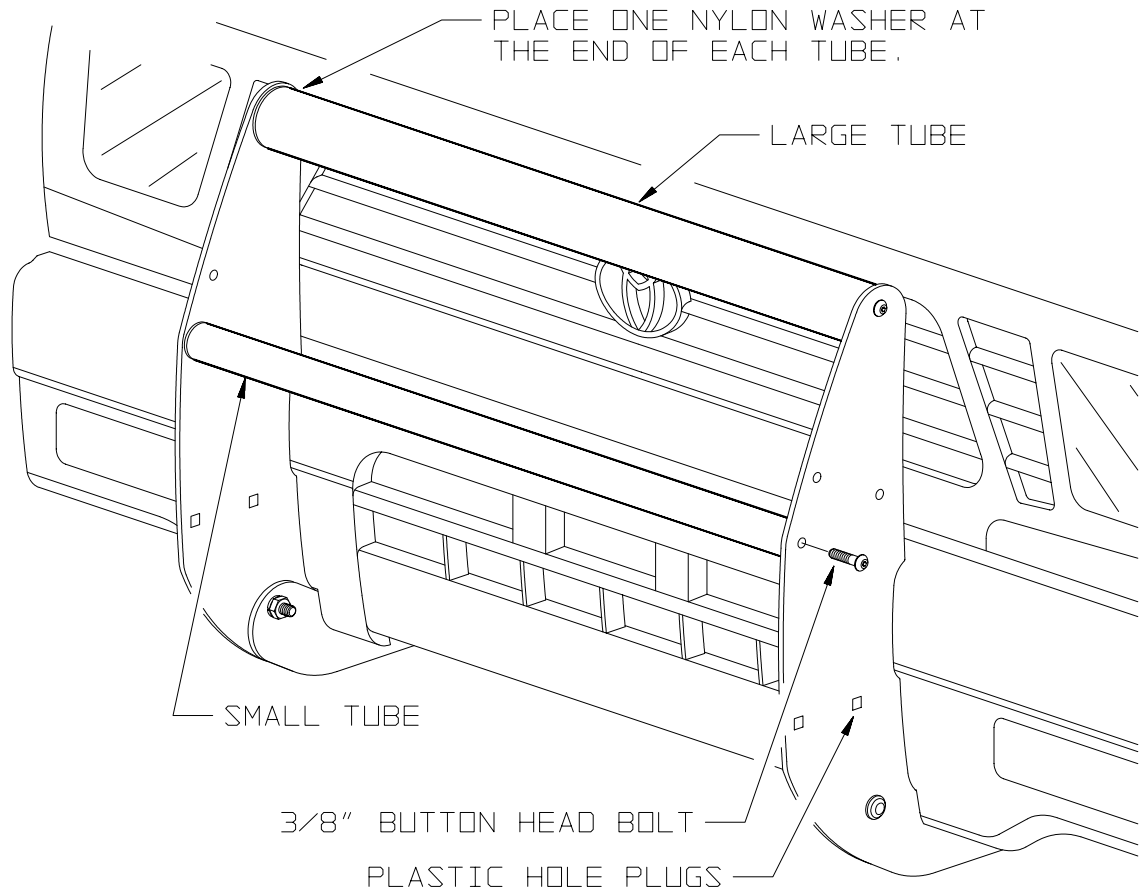

5. Align the entire assembly with the vehicle and tighten all fasteners securely. The side member fit to the bumper can be improved, if necessary, by loosening the factory bumper brackets at the frame, adjusting the bumper and then tightening.

**NOTE:** The two long braces are used only when mounting a winch. Be sure to save them if a winch is not being installed now, but may be in the future.

**If a Winch Carrier is being mounted,** install the braces as shown in **Figure 5**. Place the tail end of the brace inside the front wheel near the spindle area. Insert the forward end over the top of the vehicle frame between the radiator support and the body mount and push forward guiding it thru the opening under the bumper. Line up the forward end with the forward winch mounting holes underneath the winch carrier. With the winch in place, use 3/8 x 1-1/2 bolts thru the braces, carrier and into the winch.

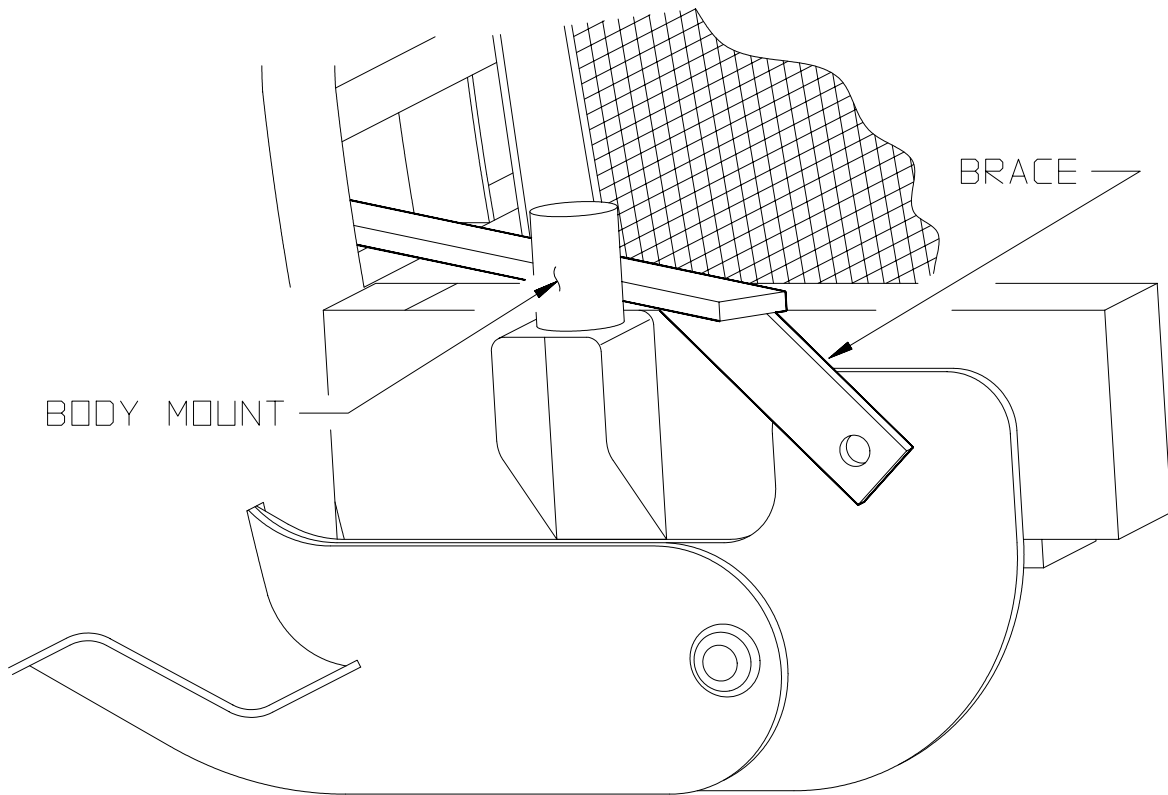
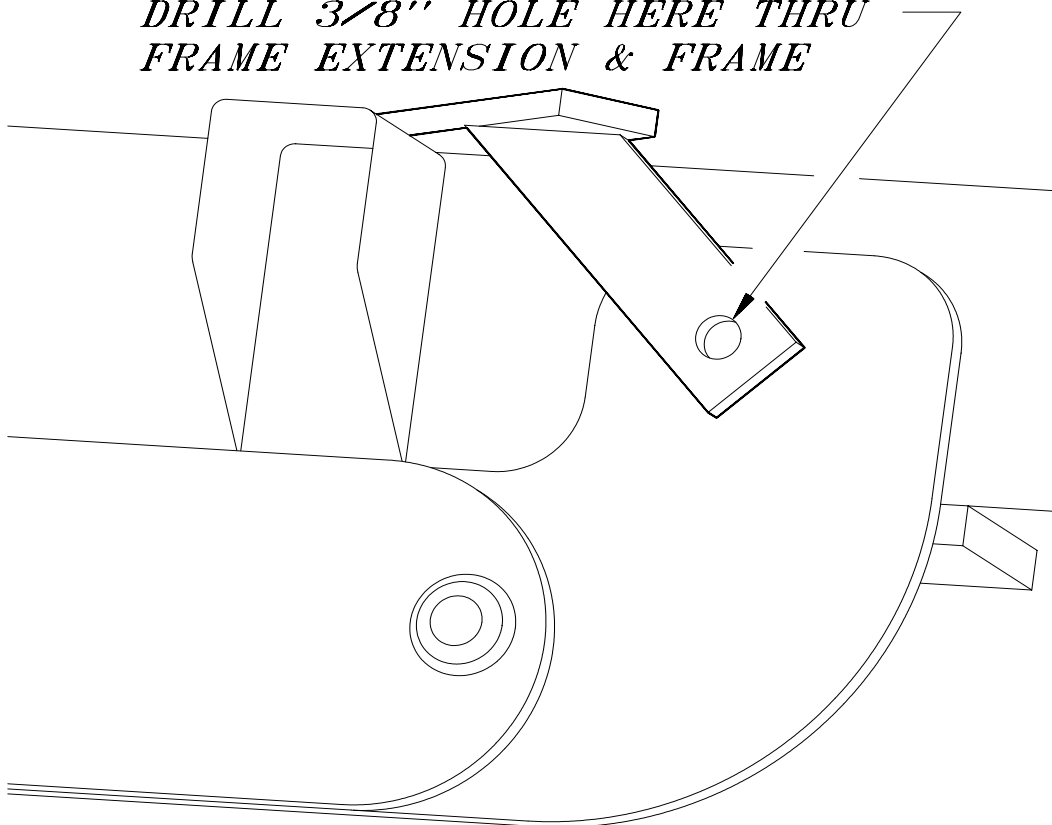

**FIGURE 5**

6. Refer to **Figure 6** and notice how the tail of the brace lies down over the rear tab area of the frame extension. Using the hole in the brace as a guide, drill a 3/8" hole thru the frame extension and on thru the vehicle frame. Secure with the 3/8" x 3-1/2" bolt.

**FIGURE 6**

***DRILL 3/8" HOLE HERE THRU  
FRAME EXTENSION & FRAME***



7. If the Receiver Kit is being mounted, first be sure that you have part no. 29397 Revision D0 or later. Earlier revisions do not have adequate flange area for the drilling required. The braces must be used and some extra cutting and hole drilling must be done. Saw 3-1/2" off of the forward ends of the braces. Place them in position as shown in **Figure 6**. Drill the frame extension and frame and secure with the 3-1/2" bolt. The braces will now be lying against the bottom of the Receiver flange, but will not line up with any holes. Drill 3/8" holes thru brace and flange at the point where the brace crosses the flange and secure with the 3/8" x 1" bolts. See **Figure 7**.

**FIGURE 7**

