



INSTALLATION INSTRUCTIONS

ATV BUMPER ACCESSORY

Bumper Kit: Warn PN 62317

Application: 2000+ Yamaha Kodiak

Your safety, and the safety of others, is very important. To help you make informed decisions about safety, we have provided installation and operating instructions and other information on labels and in this guide. This information alerts you to potential hazards that could hurt you or others. It is not possible to warn you about all potential hazards associated with this product, you must use your own good judgment.

CARELESS INSTALLATION AND OPERATION CAN RESULT IN SERIOUS INJURY OR EQUIPMENT DAMAGE. READ AND UNDERSTAND ALL SAFETY PRECAUTIONS AND OPERATING INSTRUCTIONS BEFORE INSTALLING AND OPERATING THIS PRODUCT.

This guide identifies potential hazards and has important safety messages that help you and others avoid personal injury or death.

WARNING and **CAUTION** are signal words that identify the level of hazard. These signal words mean:

WARNING signals a hazard that *could* cause serious injury or death, if you do not follow recommendations.

CAUTION signals a hazard that *may* cause minor to moderate injury, if you do not follow recommendations.

This guide uses **NOTICE** to call attention to important mechanical information, and **Note**: to emphasize general information worthy of special attention

⚠ WARNING

THE TRAIL LIGHT NEEDS TO BE MOUNTED SUCH THAT THE DRAIN HOLE FACES DOWNWARD. FAILURE TO DO SO WILL CAUSE THE LIGHT TO ACCUMULATE WATER DAMAGING THE LIGHT AND POSSIBLY THE ATV ELECTRICAL SYSTEM. FAILURE TO FOLLOW THIS WARNING MAY CAUSE VEHICLE DAMAGE AND OPERATOR INJURY OR DEATH.

FAILURE TO TIGHTEN ALL NUTS AND BOLTS SECURELY ON THE INSTALLED HARDWARE CAN RESULT IN VEHICLE DAMAGE AND OPERATOR INJURY OR DEATH.

PERFORM REGULAR INSPECTIONS ON THE BUMPER, TRAIL LIGHTS, WIRING, AND RELATED HARDWARE. NEVER OPERATE THE ATV WITH DAMAGED OR MISSING PARTS. FAILURE TO FOLLOW THIS WARNING MAY CAUSE VEHICLE DAMAGE AND OPERATOR INJURY OR DEATH.

I. PARTS LIST

<i>Ref</i>	<i>Part Number</i>	<i>Description</i>	<i>Qty</i>
A1	62377	Bumper	1
A2	61516	Strap	2
B1	13253	1/4" dia-1 1/4" long Bolt	4
B2	2008	1/4" dia-2" long Bolt	4
B3	1320	1/4" Washer	12
B4	62903	1/4" Spacer	4
B5	6725	1/4" Nylock Nut	4
-	62018	Trail Lights (<i>Sold Separately</i>)	-

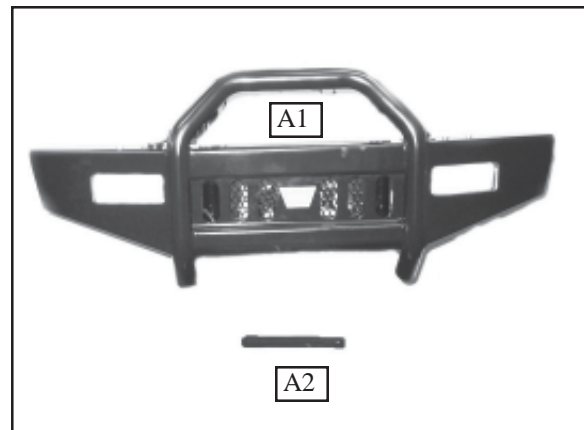

Figure 1 Kit Hardware

II. TOOLS REQUIRED

- Ratchet
- 7/16" Socket
- 10mm Socket
- 12mm Socket
- 7/16" Box Wrench
- 4mm Allen Wrench

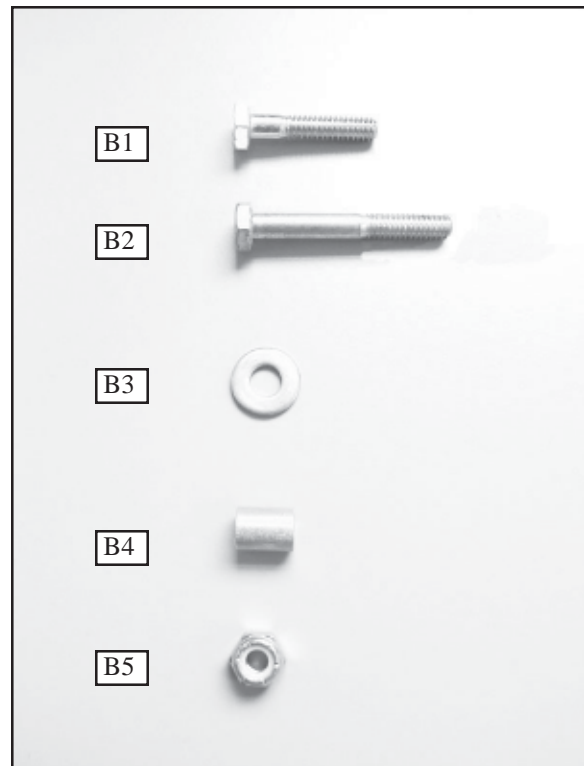

Figure 2 Kit Fasteners

III.A. TRAIL LIGHT INSTALLATION (OPTIONAL)

1. If Warn Trail Lights (PN 62018) are to be installed on the bumper, do so now prior to attaching the bumper to the ATV. Attach the trail lights to the light brackets and follow the wiring diagram as specified in the instructions that came with the trail light kit. The brackets are to be mounted with the light brackets on top.

Note: Warn Trail Lights (PN 62018) are sold separately and are not included in this kit.

2. Attach the trail lights and light brackets to the bumper using 1/4" dia-1 1/4" long Bolts (B1), 1/4" Spacers (B4), and 1/4" Nylock Nuts (B5) as shown in Figure 3. One to four 1/4" Washers (B3) may be added under each spacer to better align the light with the opening in the bumper.

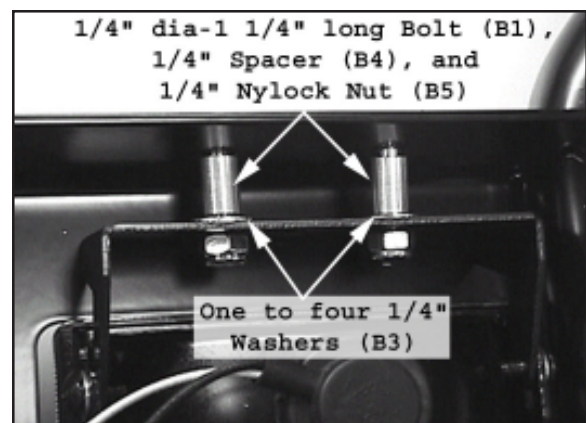

Figure 3 Install Trail Light

**III.A. TRAIL LIGHT INSTALLATION CONT.
(OPTIONAL)**

III.B. BUMPER INSTALLATION

3. Remove the top four bolts as shown in Figure 4.
4. Remove the bottom five bolts as shown in Figure 5.

Note: 2001 and older models do not have the plastic front cover, thus they do not have the middle bolt that requires removal.



Figure 4 Remove Top Bolts

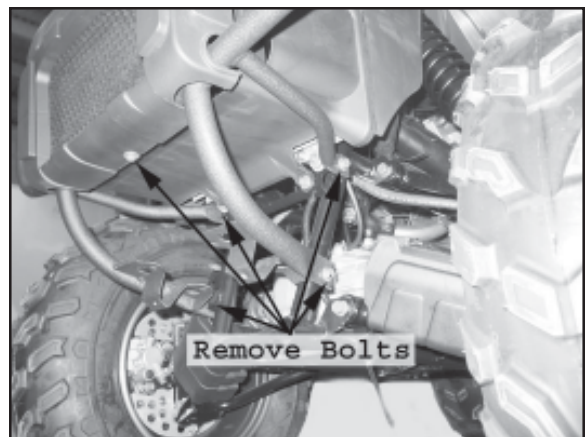

Figure 5 Remove Bottom Bolts

III. INSTALLATION CONTINUED

6. Lay the Warn Bumper (A1) face-down on the ground.
7. Remove the plastic cover, if one is installed, and place the Yamaha bumper face-down into the Warn Bumper (A1).
8. Place the Straps (A2) over the top of the Yamaha bumper and clamp the straps to the bumper by securely attaching four 1/4" dia-2" long Bolts (B2) as shown in Figure 6.
9. Reattach the bumper to the vehicle using the bolts used in Steps 4 and 5. Tighten all bolts securely. The completed assembly should look like Figure 7.

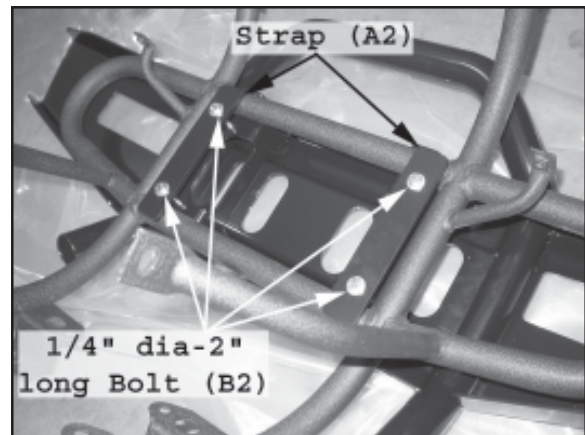

Figure 6 Attach Warn Bumper to Yamaha Bumper

⚠ WARNING

FAILURE TO TIGHTEN ALL NUTS AND BOLTS SECURELY ON THE INSTALLED HARDWARE CAN RESULT IN VEHICLE DAMAGE AND OPERATOR INJURY OR DEATH.

The bumper installation is now complete. Move onto the next section entitled "Maintenance/Care".



Figure 7 Completed Warn Bumper

IV. MAINTENANCE/CARE

1. Inspect all nuts and bolts on the bumper, trail lights, and related hardware prior to each use. Tighten all nuts that appear to be loose. Stripped, fractured, or bent bolts or nuts need to be replaced prior to use.
2. Check all wiring prior to use. Replace wiring that looks worn or broken.

⚠ WARNING

PERFORM REGULAR INSPECTIONS ON THE BUMPER, TRAIL LIGHTS, WIRING, AND RELATED HARDWARE. NEVER OPERATE THE ATV WITH DAMAGED OR MISSING PARTS. FAILURE TO FOLLOW THIS WARNING MAY CAUSE VEHICLE DAMAGE AND OPERATOR INJURY OR DEATH.