

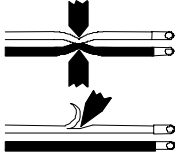

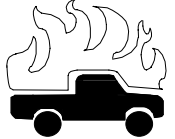

# SOLENOID REPLACEMENT KIT MOUNTING INSTRUCTIONS

As you read these instructions, you will see **NOTES**, **CAUTIONS** and **WARNINGS**. Each message has a specific purpose. **NOTES** are additional information to help you complete a procedure. **CAUTIONS** are safety messages that indicate a potentially hazardous situation which, if not avoided, may result in minor or moderate injury. A **CAUTION** may also be used to alert against unsafe practice. **WARNINGS** are safety messages that indicate a potentially hazardous situation, which, if not avoided could result in serious injury or death. **CAUTIONS** and **WARNINGS** identify the hazard, indicate how to avoid the hazard, and advise of the probable consequence of not avoiding the hazard. **PLEASE WORK SAFELY!**

	<b>⚠ WARNING</b>		<b>⚠ WARNING</b>
  	<p><b>To Prevent Serious Injury or death :</b></p> <ul style="list-style-type: none"><li>• Avoid pinch points or wear/abrasion when installing all electrical cables.</li><li>• Pinch points or wear/abrasion may cut or damage cable insulation, resulting in a direct short causing fire.</li><li>• Fire can cause injury and/or property damage.</li><li>• Insulate and protect all exposed wiring and electric terminals.</li><li>• Read and follow all wiring instructions.</li></ul>	 	<p><b>To Prevent Serious Injury or death :</b></p> <ul style="list-style-type: none"><li>• Frequently inspect all electrical cables for pinch points or wear/abrasion.</li><li>• Replace damaged or worn electrical cables.</li><li>• Damaged electrical cables can cause fire.</li></ul>

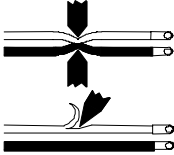
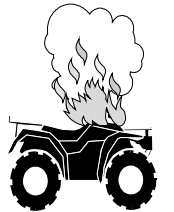
## **⚠ WARNING**

- **INSULATING PLASTIC WASHERS OR CLIPS MUST BE USED PER THE INSTRUCTIONS.**
- **READ, UNDERSTAND, AND FOLLOW THE SOLENOID INSTALLATION INSTRUCTIONS PROVIDED BELOW.**
- **INCORRECT INSTALLATION MAY RESULT IN FIRE, SERIOUS INJURY OR DEATH.**

## **⚠ WARNING**

- **BATTERIES CONTAIN GASSES WHICH ARE FLAMABLE AND EXPLOSIVE.**
- **WEAR EYE PROTECTION DURING DISCONNECTION AND INSTALLATION.**
- **ALWAYS REMOVE ALL METAL JEWELRY.**
- **DO NOT LEAN OVER BATTERY WHILE MAKING CONNECTIONS.**
- **FAILURE TO TAKE PROPER PRECAUTION MAY RESULT IN FIRE, SERIOUS INJURY OR DEATH.**

## STEP 1: REMOVE EXISTING SOLENOID

1. Disconnect the (-) negative battery terminal **first**.
2. Disconnect the (+) positive terminal **second**.
3. Remove all wires and mounting hardware that is attached to the existing solenoid.
4. Leave all protective weather boots on all the wires and battery cables. These boots will be used with the replacement solenoid.
5. Inspect all winch wiring for wear/abrasion, pinch points, and other damage. If found, contact dealer or distributor for replacement wiring.

## STEP 2: INSTALLATION OF NEW REPLACEMENT SOLENOID

The solenoid is a primary safety feature in your winch system. Carefully follow the instructions for installation. The new replacement solenoid must be correctly installed to work properly. ***Choose a mounting location that will remain protected and dry.***

1. The new replacement solenoid housing must be electrically isolated from the vehicle chassis. Carefully follow the diagram below, FIGURE 1, for mounting the solenoid. Failure to do so could result in the solenoid shorting to ground with the potential for causing the vehicle to catch fire.
2. **DO NOT DRILL OUT, SUBSTITUTE, OR ALTER THE PLASTIC INSULATING CLIPS.**
3. Do not use fasteners larger than #10.
4. Utilize both tabs to secure the new replacement solenoid.

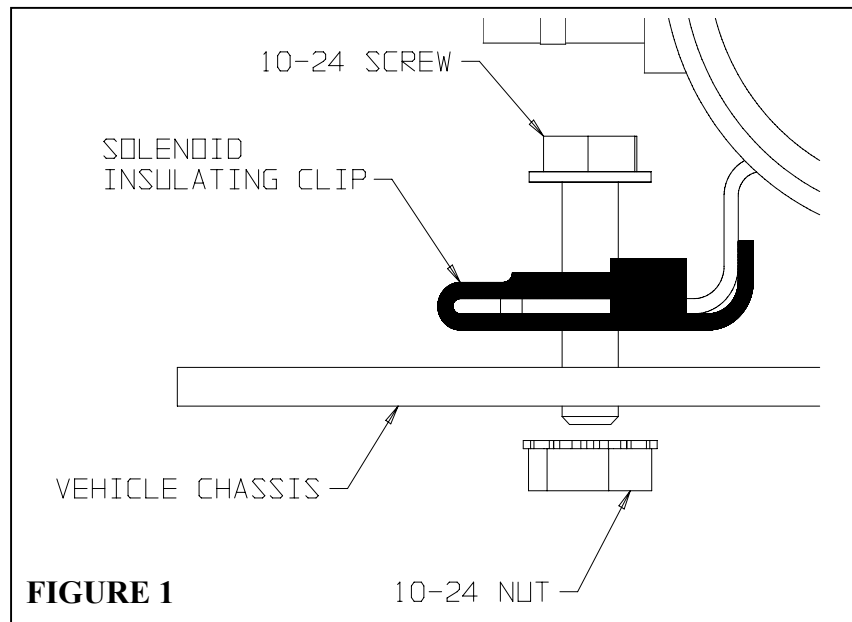

### STEP 3: WIRING DIRECTIONS AND SCHEMATIC

*When attaching wire terminals to the solenoid, do not remove inner nuts.*

1. Re-install wires, FIGURE 2, and all protective boots over solenoid posts.
2. Re-attach positive lead to positive battery post. Reattach negative lead to negative battery post.
3. Test for proper installation. When the key and/or toggle switch (if installed) is turned to the ON position, the solenoid will make an audible “click” indicating that it is energized. Otherwise, check for proper grounding and other electrical connections.

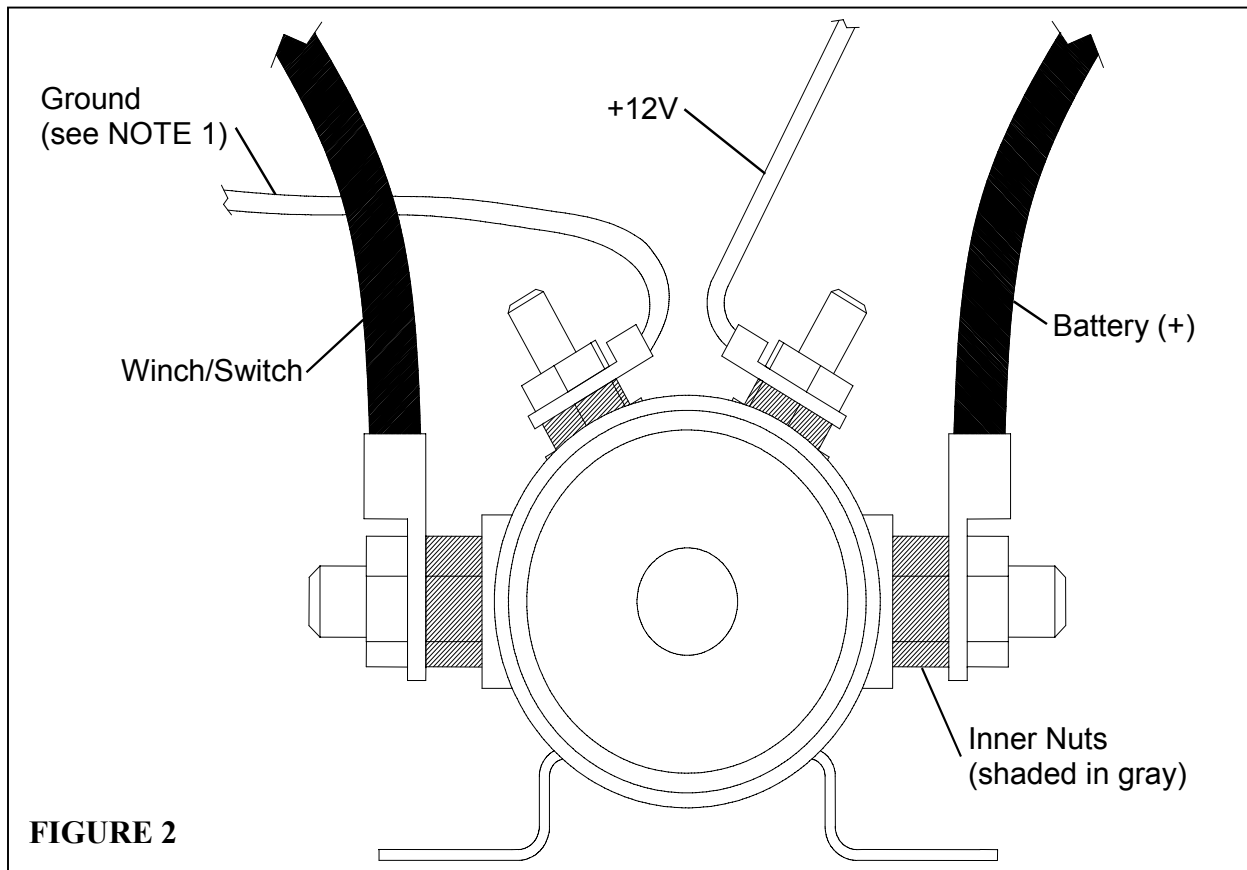

**NOTE 1: If replacing a 3 terminal solenoid, a 20ga ground wire must be added as shown in FIGURE 2 above. This wire must be connected to a chassis ground.**