



INSTALLATION INSTRUCTIONS

ATV BUMPER ACCESSORY

Bumper Kit: Warn PN 63307

Application: 2002+ Arctic Cat 500/400/375/300

Your safety, and the safety of others, is very important. To help you make informed decisions about safety, we have provided installation and operating instructions and other information on labels and in this guide. This information alerts you to potential hazards that could hurt you or others. It is not possible to warn you about all potential hazards associated with this product, you must use your own good judgment.

CARELESS INSTALLATION AND OPERATION CAN RESULT IN SERIOUS INJURY OR EQUIPMENT DAMAGE. READ AND UNDERSTAND ALL SAFETY PRECAUTIONS AND OPERATING INSTRUCTIONS BEFORE INSTALLING AND OPERATING THIS PRODUCT.

This guide identifies potential hazards and has important safety messages that help you and others avoid personal injury or death.

WARNING and **CAUTION** are signal words that identify the level of hazard. These signal words mean:

WARNING signals a hazard that *could* cause serious injury or death, if you do not follow recommendations.

CAUTION signals a hazard that *may* cause minor to moderate injury, if you do not follow recommendations.

This guide uses **NOTICE** to call attention to important mechanical information, and **Note**: to emphasize general information worthy of special attention

▲ WARNING

FAILURE TO TIGHTEN ALL NUTS AND BOLTS SECURELY ON THE INSTALLED HARDWARE CAN RESULT IN VEHICLE DAMAGE AND OPERATOR INJURY OR DEATH.

PERFORM REGULAR INSPECTIONS ON THE BUMPER, TRAIL LIGHTS, WIRING, WINCH, WINCH CABLE, AND RELATED HARDWARE. NEVER OPERATE THE ATV WITH DAMAGED OR MISSING PARTS. FAILURE TO FOLLOW THIS WARNING MAY CAUSE VEHICLE DAMAGE AND OPERATOR INJURY OR DEATH.

I. PARTS LIST

<u>Ref</u>	<u>Part Number</u>	<u>Description</u>	<u>Qty</u>
A1	63305	Bumper	1
B1	13253	1/4" dia-1 1/4" long Bolt	4
B2	1320	1/4" Washer	12
B3	62903	1/4" Spacer	4
B4	6725	1/4" Nylock Nut	4
C1	22508	8mm dia-25mm long Bolt	4
C2	1324	5/16" Washer	4
C3	1402	5/16" Lock Washer	4
-	62018	Trail Lights (<i>Sold Separately</i>)	-

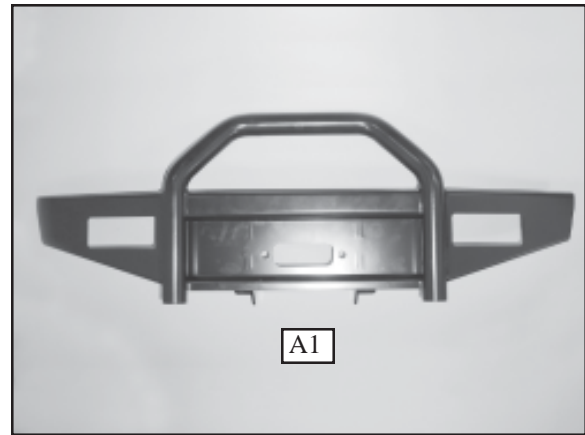

Figure 1 Kit Hardware

II. TOOLS REQUIRED

- Ratchet
- 7/16" Socket
- 7/16" Box Wrench
- 13mm Socket or Wrench

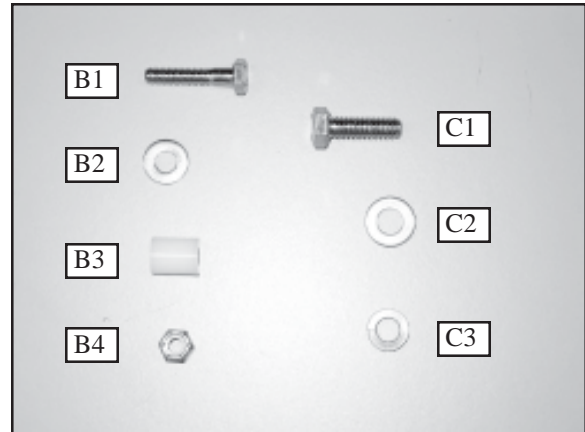

Figure 2 Kit Fasteners

III.A. TRAIL LIGHT INSTALLATION (OPTIONAL)

1. If Warn Trail Lights (PN 62018) are to be installed on the bumper, do so now prior to attaching the bumper to the ATV. Attach the trail lights to the light brackets and follow the wiring diagram as specified in the instructions that came with the trail light kit. The brackets are to be mounted with the light brackets on top. Do not use the U-bolts or attach the lights to the vehicle.

Note: Warn Trail Lights (PN 62018) are sold separately and are not included in this kit.

2. Attach the trail lights and light brackets to the bumper using 1/4" dia-1 1/4" long Bolts (B1), 1/4" Spacers (B3), and 1/4" Nylock Nuts (B4) as shown in Figure 3. One to four 1/4" Washers (B2) may be added under each spacer to better align the light with the opening in the bumper.

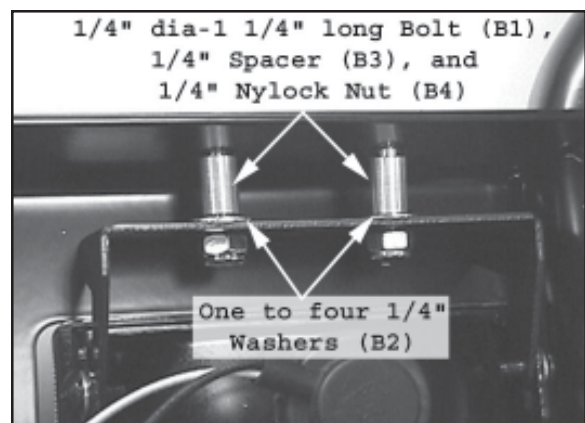

Figure 3 Install Trail Light

III.B. BUMPER INSTALLATION

1. Remove the bolts as shown in Figure 4.

Note: If installing the bumper over the fixed winch mount, remove the same four bolts but hold the winch mount in place; otherwise, the winch and winch mount may fall out of the vehicle. Also, remove the roller failead or hause and reinstall the 5/16" bolts back into the winch and winch mount.

2. Install the bumper over the exposed four holes using 8mm dia-25 mm long bolts (C1), 5/16" washers (C2), and 5/16" lock washers (C3) as shown in Figure 5. The lock washer should be placed between the flat washer and the head of the bolt. It is recommended to install the top bolts first for easier installation.

Note: If installing the bumper over the fixed winch mount, it may be difficult to align both the winch mount and bumper to the same holes. To ease installation, thread 8mm bolts through the bottom of just the winch mount. Thread the top two bolts through the top holes in both the winch mount and bumper. Remove the bottom bolts and reinstall through both the bumper and winch mount.

⚠ CAUTION

BE CAREFUL IF INSTALLING THE BUMPER OVER A WINCH MOUNT. UNLESS CARE IS TAKEN, THE WINCH AND WINCH MOUNT MAY FALL OUT OF THE VEHICLE DAMAGING THE WINCH AND INJURING THE INSTALLER. IT IS STRONGLY RECOMMENDED TO INSTALL THE BUMPER OVER THE WINCH MOUNT WITH THE ASSISTANCE OF ANOTHER PERSON.

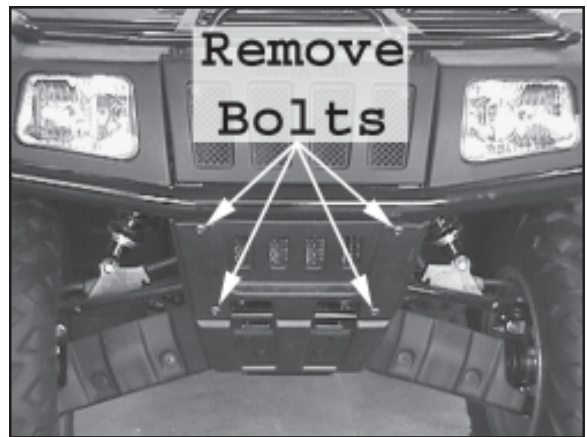

Figure 4 Remove Bolts

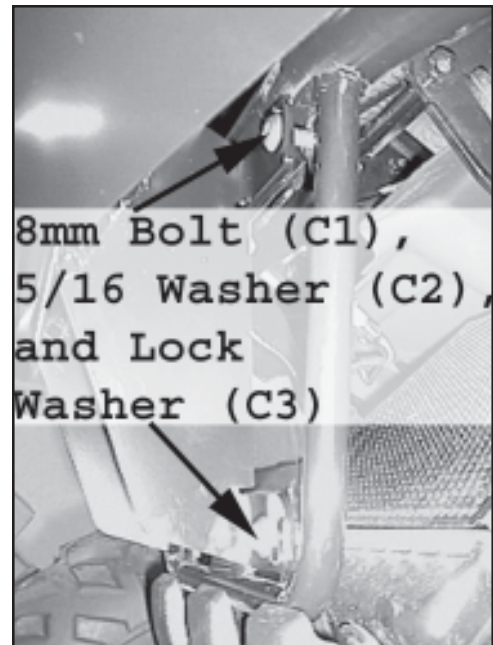

Figure 5 Install 8mm Bolts

III. INSTALLATION CONTINUED

3. Tighten all four 8mm dia-25mm long bolts (C1) securely. Recommended torque is 7 ft-lbs.

⚠ WARNING

FAILURE TO TIGHTEN ALL NUTS AND BOLTS SECURELY ON THE INSTALLED HARDWARE CAN RESULT IN VEHICLE DAMAGE AND OPERATOR INJURY OR DEATH.

Note: If installing the bumper over the fixed winch mount, install the roller fairlead or hause (removed in step one) and attach it to the bumper using the hardware that came with the roller fairlead or hause. The roller fairlead or hause should be mounted using 3/8" dia-3/4" long bolts and nylock nuts, or similar. A roller fairlead is strongly recommended over the hause as the hause will quickly wear the winch cable. If the bumper is installed over an Arctic Cat winch mount (has two rounded rod handles), a roller fairlead must also be used on the winch mount to prevent cable wear. A roller fairlead kit (Warn Part Number 28929) can be purchased separately.

The bumper installation is now complete and should look like Figure 6. Move onto the next section entitled "Maintenance/Care".



Figure 6 Installed Bumper

IV. MAINTENANCE/CARE

1. Inspect all nuts and bolts on the bumper, trail lights, winch, winch cable, and related hardware prior to each use. Tighten all nuts that appear to be loose. Stripped, fractured, or bent bolts or nuts and wore or frayed cables need to be replaced prior to use.
2. Check all wiring prior to use. Replace wiring that looks worn or broken.

⚠ WARNING

PERFORM REGULAR INSPECTIONS ON THE BUMPER, TRAIL LIGHTS, WIRING, WINCH, WINCH CABLE, AND RELATED HARDWARE. NEVER OPERATE THE ATV WITH DAMAGED OR MISSING PARTS. FAILURE TO FOLLOW THIS WARNING MAY CAUSE VEHICLE DAMAGE AND OPERATOR INJURY OR DEATH.