



INSTALLATION INSTRUCTIONS

Trans4mer Gen II Mount System For 2007-2010 Dodge Ram HD 4500/5500 Bracket Kit 90145

Your safety, and the safety of others, is very important. To help you make informed decisions about safety, we have provided installation and operating instructions and other information on labels and in this guide. This information alerts you to potential hazards that could hurt you or others. It is not possible to warn you about all potential hazards associated with this product, you must use your own good judgment.

CARELESS INSTALLATION AND OPERATION CAN RESULT IN SERIOUS INJURY OR EQUIPMENT DAMAGE. READ AND UNDERSTAND ALL SAFETY PRECAUTIONS AND OPERATING INSTRUCTIONS BEFORE INSTALLING AND OPERATING THIS PRODUCT.

This guide identifies potential hazards and has important safety messages that help you and others avoid personal injury or death. **WARNING** and **CAUTION** are signal words that identify the level of hazard. These signal words mean:

⚠ WARNING signals a hazard that could cause serious injury or death, if you do not follow recommendations.

⚠ CAUTION signals a hazard that may cause minor to moderate injury, if you do not follow recommendations.

This guide uses **NOTICE** to call attention to important mechanical information, and **Note**: to emphasize general information worthy of special attention.

⚠ WARNING

Failure to observe these instructions could lead to severe injury or death.

- Always** wear safety glasses when installing this kit.
- Always** use extreme caution when cutting and trimming during fitting.
- Always** remove jewelry and wear eye protection.
- Always** use appropriate and adequate care in lifting components into place.
- Always** insure components will remain secure during installation and operation.
- Always** tighten all nuts and bolts securely, per the installation instructions.

⚠ WARNING

Failure to observe these instructions could lead to severe injury or death.

- Always** securely tighten all bolts on the winch plate, winch, and fairlead. Loose bolts can result in product failure which may result in vehicle damage and operator injury or death.
- Always** double check that all bolts are securely tightened prior to use.

This WARN Trans4mer Gen II system can be customized to give your vehicle a wide variety of looks, front-end protection and winch mounting capability. The system starts with this winch carrier that attaches to the truck's frame with brackets designed to handle up to a 16500 lb winch. This provides a mounting location for a Warn winch. It is durable and good looking as a stand-alone winch mount, but can be easily upgraded with some great options! You can first add a center Grille Guard Tube that provides a mounting location for other accessories. You can add a light bar that adds even more protection and includes tabs for mounting auxiliary lights. You can mount a front receiver bracket that provides a mounting location for a multi-mount Warn winch. Finally, headlamp guards that protect the headlights and front corners of the vehicle can be easily added to any of the options above.

Before You Begin

- Read and understand these Installation Instructions.
- Refer to the Parts List below and to Figure A for your specific mounting system to become familiar with the components and hardware in this kit.

I. PARTS LIST FOR 90145 Bracket Kit

<u>Part Number.</u>	<u>Qty</u>	<u>Description</u>
81327	1	Bottom Bracket, LH
81326	1	Bottom Bracket, RH
82046	1	Hardware kit
81263	1	Frame Extension, RH
81262	1	Frame Extension, LH

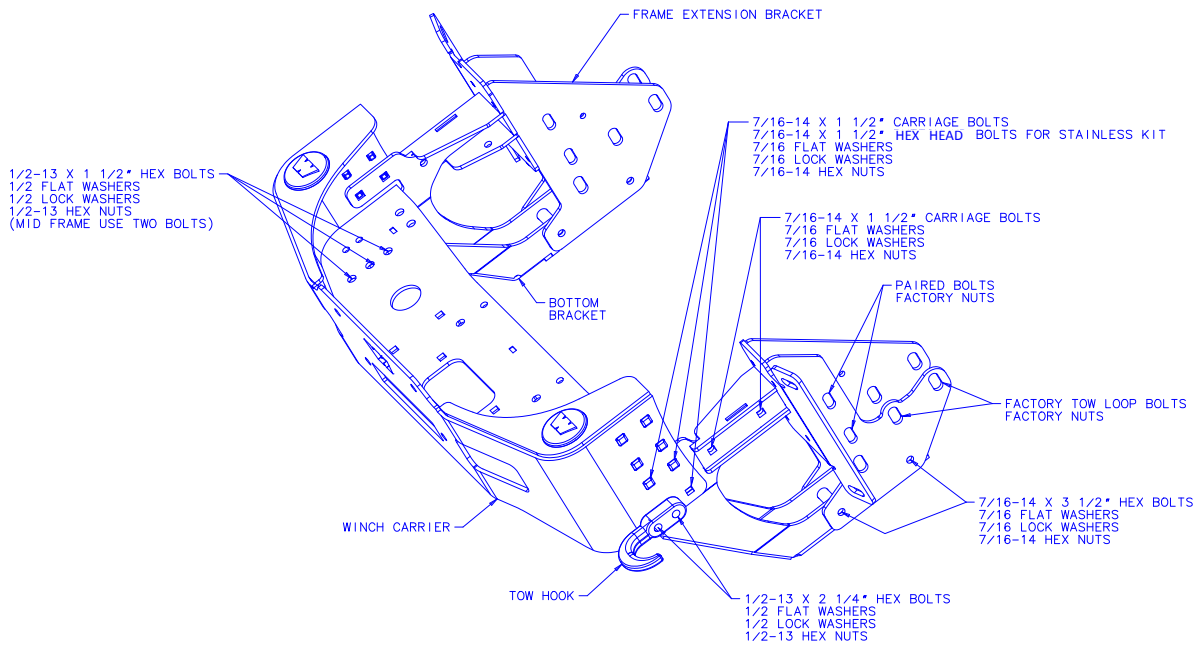

**Figure A: Large Frame Fastener Placement
(Mid Frame Not Shown Fastener Placement the Same Except as Noted)**

NOTE: Follow the instructions step by step for fastest installation. Do not securely tighten fasteners until directed to do so.

III. TORQUE SPECIFICATIONS

BOLT SIZE	TORQUE
3/8 inch	30 lb. ft (40.7 N-m)
7/16 inch	50 lb. ft. (67.8 N-m)
1/2 & 5/8 inch	75 lb. ft. (101.7 N-m)

V. VEHICLE PREPARATION

- a) Review all illustrations to become familiar with the kit components.
- b) Remove the gray plastic insert(s) from the center of the bumper, if so equipped. Unscrew the fasteners and remove. The insert(s) will not be reinstalled. Note the spacing between the headlights and the top of the bumper. You will want to return the bumper to this spacing after installation. If the vehicle is equipped with factory tow loops, remove them now. They will not be used with the Grille Guard. Do not discard the tow loop bolts. They will be re-used later.

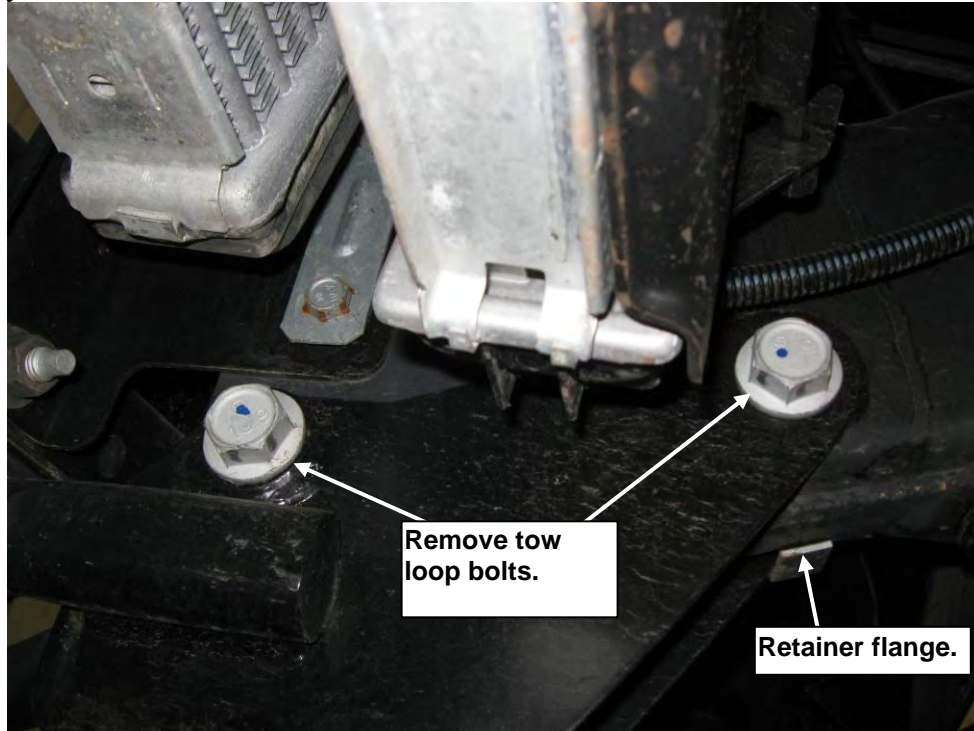

Figure AA Bolts attaching tow loops to frame (viewed from center of vehicle, looking outward)

- c) Remove three (3) hex screws from each bumper end. They are located in the front wheel well on each side of the vehicle.



Figure BB: Bolts attaching bumper brackets to frame (viewed from center of vehicle, looking outward)

3. Remove bumper with brackets. Unplug the factory fog lamps if so equipped. Support the bumper then remove the “paired bolts” attaching the bumper brackets to the frame. See **Figure BB**

Vehicles with diesel engines might require removal of the upper intercooler mounting bolts. Remove the bolts then lift the intercooler enough to remove the “paired bolts” (about 3/4”). Temporarily slide the intercooler back in place. See **Figure CC**

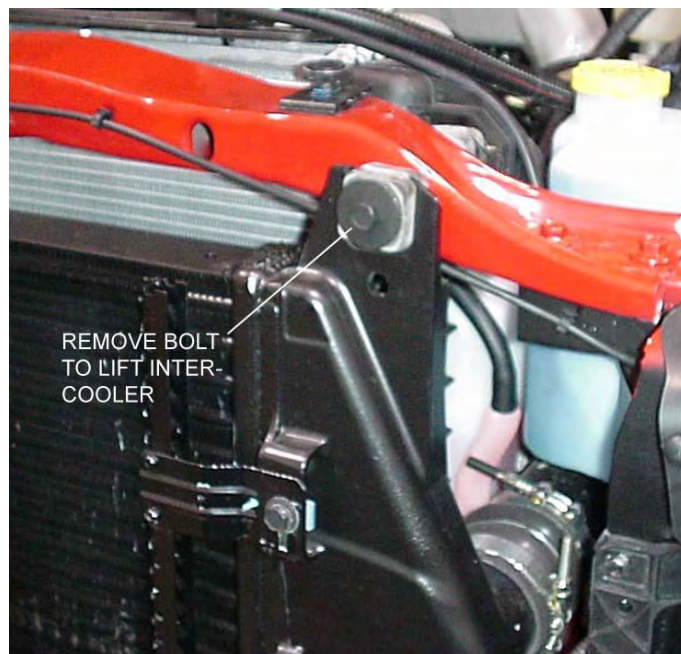

Figure CC: Left (driver side) diesel intercooler bolt

- d) Remove the brackets from the bumper. Remove the three (3) nuts holding each bracket in place. Save the nuts to reattach the bumper later. The brackets will not be reinstalled.

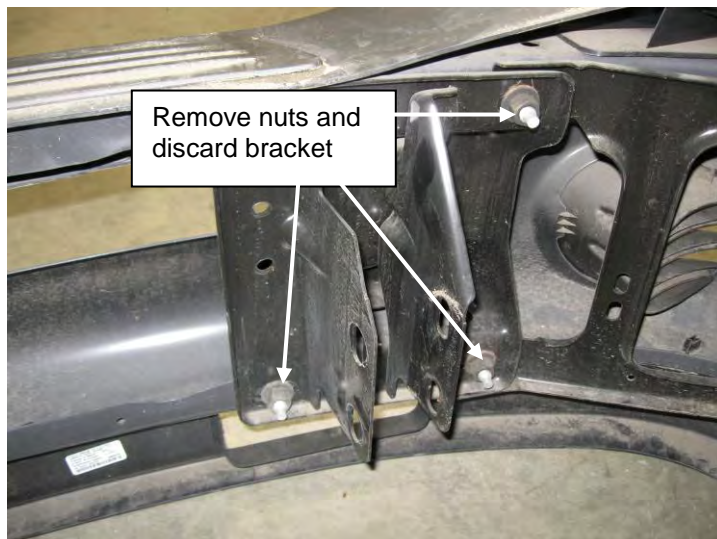

Figure DD OEM bumper bracket removal.

VI. INSTALLATION:

1. Install the appropriate Frame Extension bracket. Push the factory tow loop bolts through the Frame Extension and install the factory nut on each. Lift the intercooler and reinstall the factory "paired bolts" from the inside, through the Frame Extension. Install the factory nuts. Do not tighten any hardware yet. Repeat for the opposite side. See **Figure 1**.

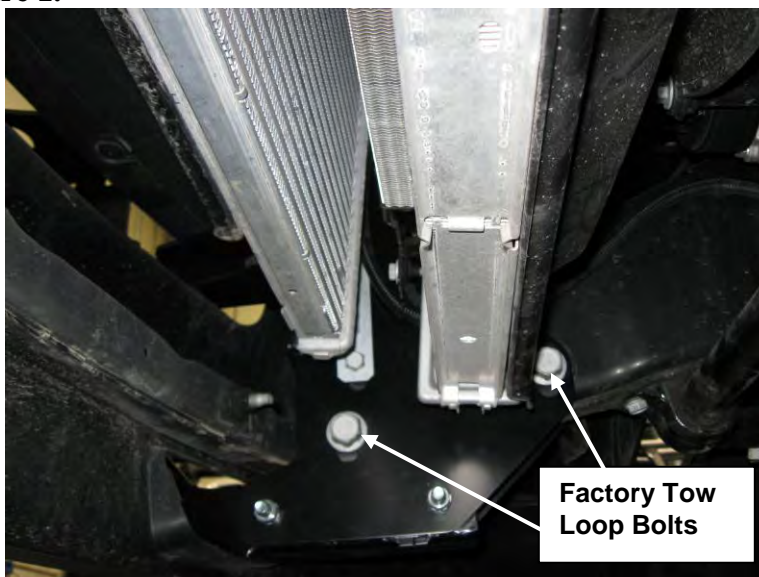

Figure 1: Bolts attaching Frame Extension Bracket to frame (viewed from center of vehicle, looking outward)

2. Reinstall bumper onto vehicle. The frame extension will protrude through the long opening in the bumper. Align the bumper bolts with the slots in the front plate of the frame extension bracket. Once the bumper bolts are installed through the slots, re-install the factory nuts on the bumper bolts. Do not tighten any hardware yet.

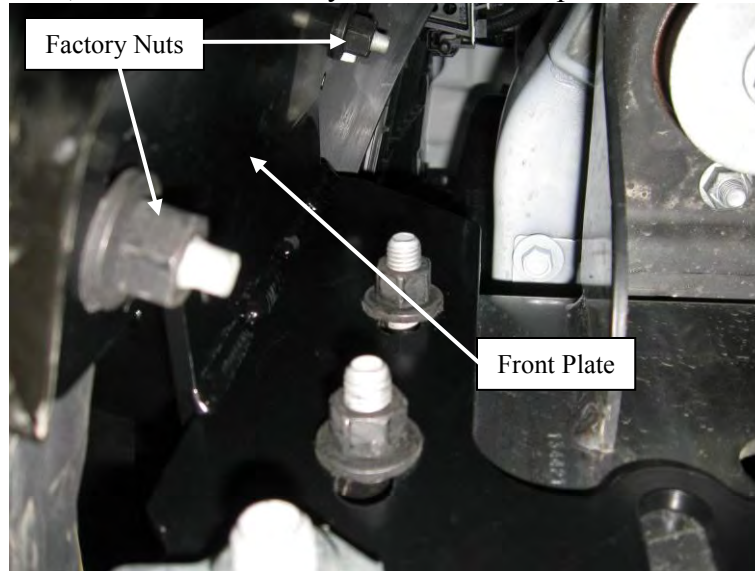

Figure 2: Bolts attaching Frame Extension Bracket to bumper (viewed from center of vehicle, looking outward)

3. Install the bottom brackets onto the winch carrier as shown in figure 4. **Note: if installing a Large Frame Carrier, install the reinforcing bracket according to the instructions provided with the carrier.** On the large frame carriers it is necessary to install the bottom brackets at an angle to fit the bracket around the stiffener flange. **See figure 3.** Install 3 each 7/16-14 x 1 1/2" Carriage Bolt as shown in figure 4. If installing a stainless kit, use stainless hex head bolts and washers (provided in carrier hardware kit) in place of carriage bolts. Install a flat washer, lock washer, and nut on the bolt. Repeat for the opposite side. Do not tighten any hardware yet.

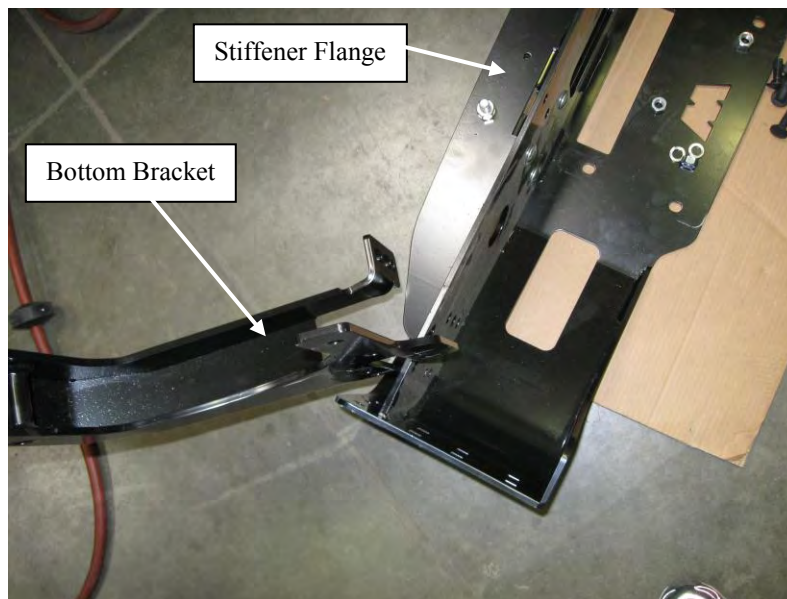

Figure 3: Large Frame Carrier: Install Bottom Bracket at an angle to get around Stiffener Flange.

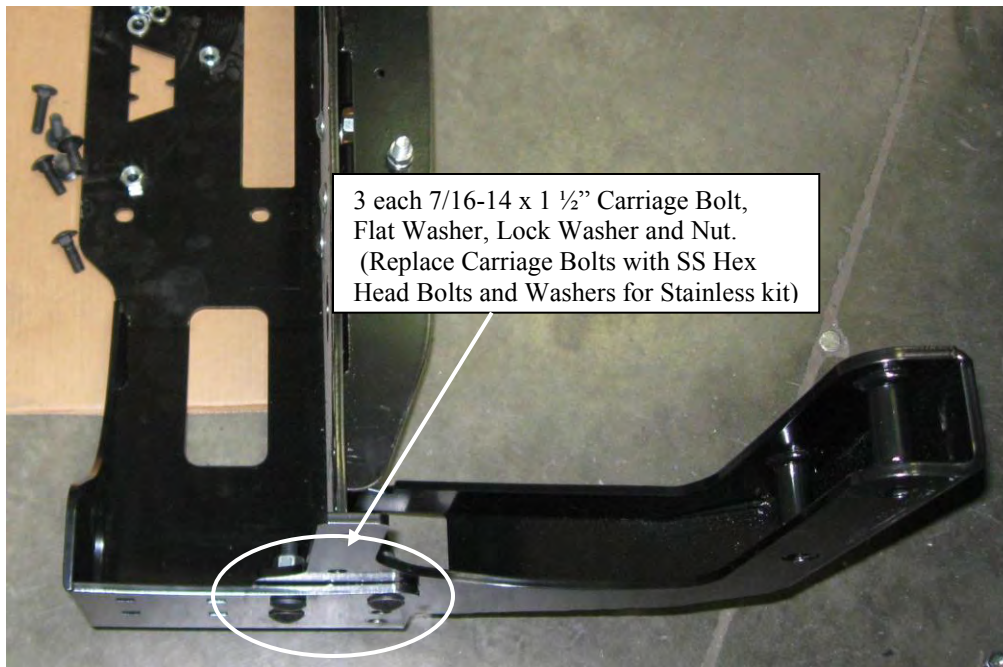

Figure 4: Large Frame Carrier: Installed Bottom Bracket.

4. Install the bottom bracket and carrier assembly onto the frame extension bracket and align the holes. Install 2 each 7/16-14x3 1/2" hex bolts into bottom holes of frame extension through the bottom bracket and frame. Install flat washer, lock washer and hex nut on each bolt. Do not tighten any hardware yet. Repeat for the opposite side.

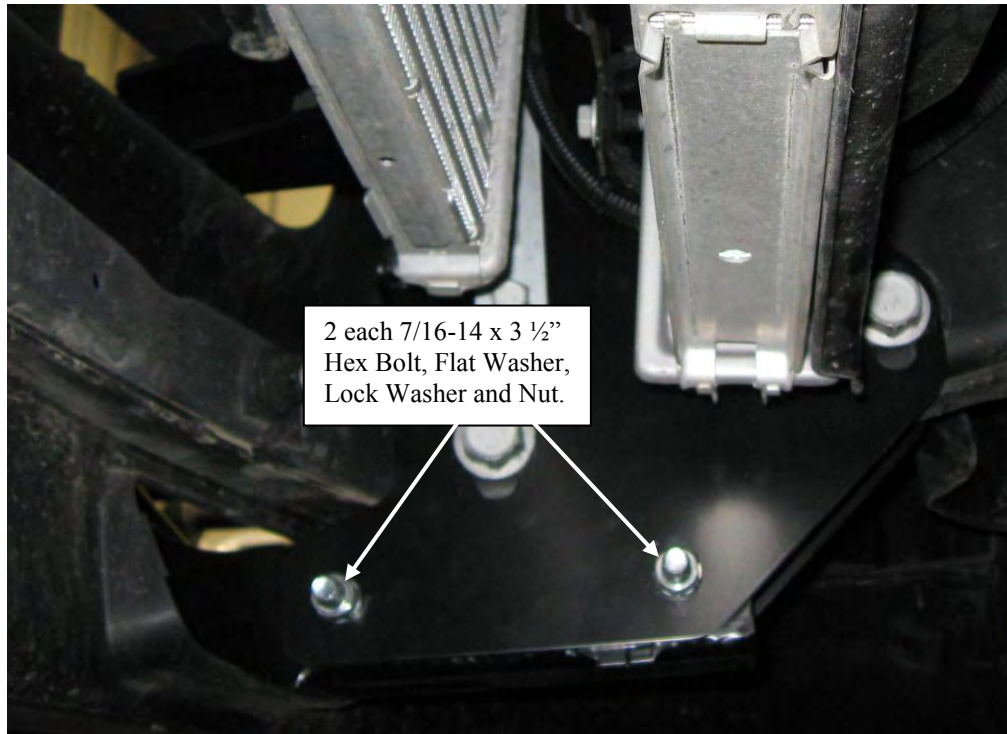

Figure 5: Large Frame Carrier: Lower bolt position.

5. Install 2 each 7/16-14 x 1 1/2" carriage bolts through the frame extension and bottom bracket as shown in **Figure 6**. Do not tighten any hardware yet. Repeat for the opposite side.



Figure 6: Large Frame Carrier: Top Carriage Bolt Positions.

6. Install 3 each 1/2-13 x 1 1/2" Hex Head Bolts through the three holes on the right side of the carrier plate and through the bottom bracket as shown in **Figure 5**. Install a flat washer, lock washer, and nut on the bolt. Repeat for the opposite side. Do not tighten any hardware yet.

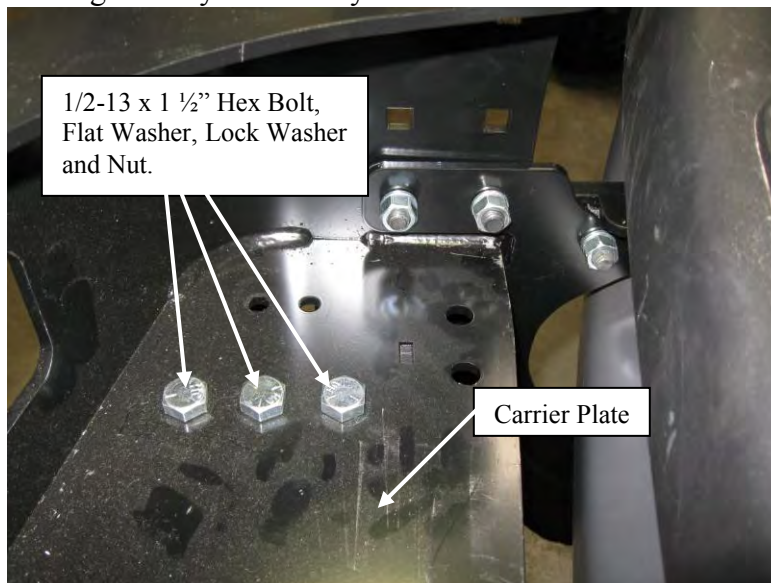

Figure 7: Large Frame Carrier: Carrier Plate Hex Bolt Positions.

7. Install the tow hooks as shown in figure 6 using black $\frac{1}{2}$ -13 x $2\frac{1}{4}$ " bolts with the black hooks and Zinc $\frac{1}{2}$ -13 x $2\frac{1}{4}$ " bolts with the chrome hooks. Install a flat washer, lock washer, and nut on the bolt. Repeat for the opposite side. Do not tighten any hardware yet.

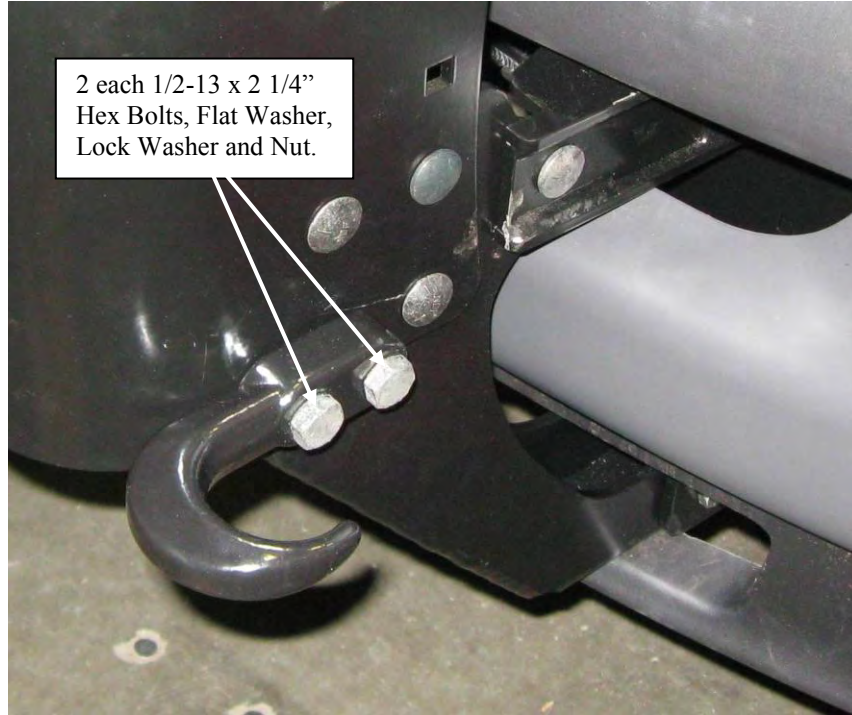

Figure 8: Large Frame Carrier: Tow Hook Bolt Positions.

8. With assistance, adjust the height of the bumper to match the original spacing between bumper and head lights before removing the bumper in step b). While bumper is held in position tighten all 4 large tow loop bolts to hold bumper in position. Torque to 75 lb. ft. (101.7 N-m).

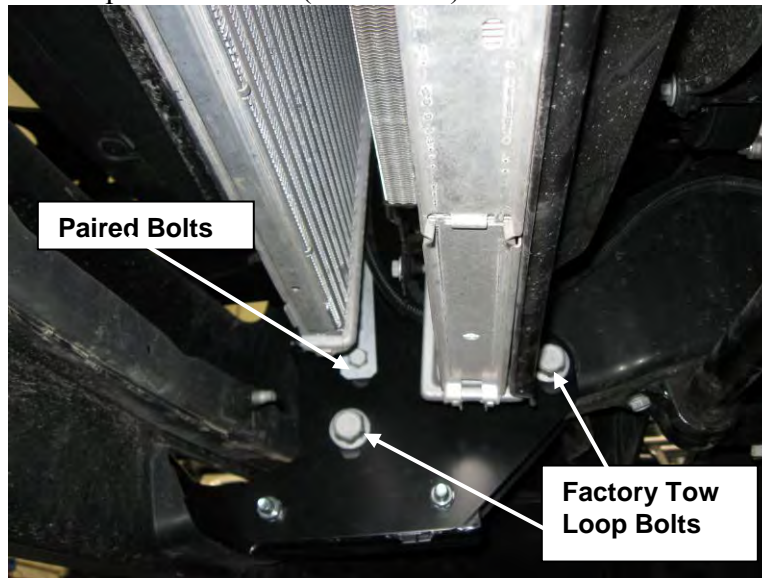

Figure 9: Large Frame Carrier: Bolt Positions.

9. Tighten all 4 nuts on the paired bolts and torque to 50 lb. ft. (67.8 N-m). See **Figure 9**.

10. Adjust the bumper to center it left to right on vehicle. Flares should line up evenly with the bumper ends on both sides. Tighten all 4 factory nuts that attach the bumper to the frame extension Front Plate and torque to 50 lb. ft. (67.8 N-m). See **Figure 10**.

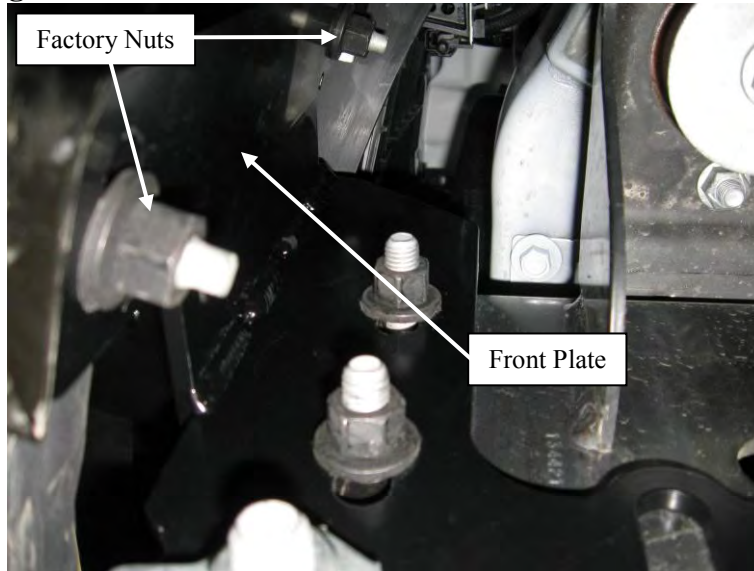

Figure 10: Large Frame Carrier: Bumper Factory Nut Positions.

11. Tighten the 4 remaining bolts at the bottom of the frame extension brackets and torque to 50 lb. ft. (67.8 N-m). See **Figure 9**.
12. Tighten the 4 carriage bolts that connect the bottom bracket to the frame extension bracket that protrudes through the bumper and torque to 50 lb. ft. (67.8 N-m). See **Figure 11**.

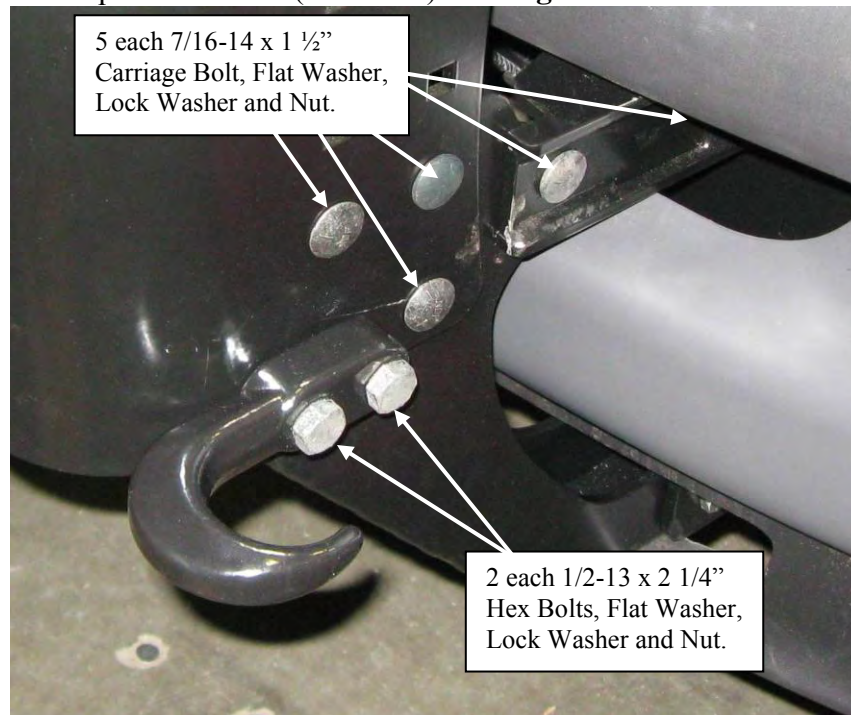

Figure 11: Large Frame Carrier: Carriage and Tow Hook Bolt Positions.

13. Tighten the tow hook bolts on the outside of the winch carrier and torque to 75 lb. ft. (101.7 N-m). See **Figure 11**.
14. Tighten the carriage bolts (Hex Head Bolts for SS kits) behind and above the tow hook and torque to 50 lb. ft. (67.8 N-m). See **Figure 11**.

15. Tighten the six hex bolts as shown in **Figure 12** and torque to 50 lb. ft. (67.8 N-m).

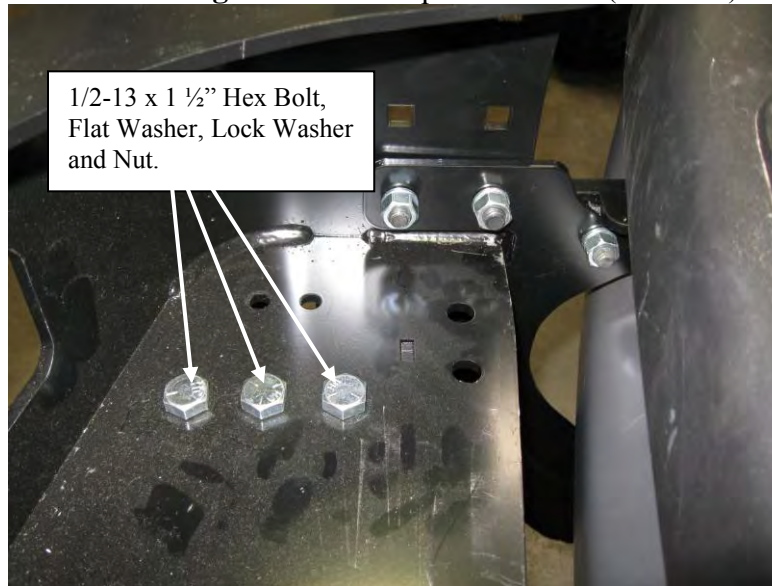

Figure 12: Large Frame Carrier: Carriage Hex Bolt Positions.

16. Verify all bolts in the Trans4mer kit are tightened to the torque values specified.

17. If installing a winch, install it now following the instructions provided by the winch manufacturer.

18. Once the winch is installed proceed with installation of Center Tube, Light Bar and Headlamp Guards as needed.

Installation instructions are provided with each kit.

19. Installation of this kit is now complete. Thank you for purchasing the WARN Gen II Trans4mer Kit.



Figure 13: Finished kit (Winch Not Included)

⚠ WARNING

FAILURE TO SECURELY TIGHTEN ALL BOLTS ON THE WINCH PLATE, WINCH, AND FAIRLEAD CAN RESULT IN PRODUCT FAILURE WHICH MAY RESULT IN VEHICLE DAMAGE AND OPERATOR INJURY OR DEATH. DOUBLE CHECK THAT ALL BOLTS ARE SECURELY TIGHTENED PRIOR TO USE.

Warn Industries Stainless Steel Truck Accessories

What to expect:

Polished stainless steel combines the beauty of a chrome-like appearance with extreme durability and corrosion resistance. With a minimum amount of care, the appearance will last almost indefinitely. Unlike plating or coatings, there is nothing to peel off or wear away that would allow corrosion underneath.

The actual appearance may not be exactly like new chrome in either the degree of luster or color. There may be fine polishing lines visible up close and small differences between mating parts of an assembly. A grille guard, for instance, may have small differences between the round tubing and the flat plate. The backside of a part may not be as highly polished as the front. However, part of the beauty and appeal of stainless actually lies in the smooth “hand-worked” appearance.

There also is a possibility that small rust spots can appear on stainless products. They are usually due to minor iron contamination on the surface as a result of normal manufacturing and handling processes. This minor rust, if it occurs at all, is easy to remove and will not tend to spread.

Recommended care:

Regular washing with fresh water and mild car wash detergents followed by rinsing and drying with a soft towel is the best minimum care. Beyond that, any cleaner/wax recommended for automotive finishes will work well to remove minor stains and scuffs, enhance the shine and provide protection. Always use clean soft cotton cloths. In most cases, this will be all that is required for many years. For more serious blemishes or a rust spot, use a cream metal polish recommended for stainless, aluminum, etc. Try to rub in the direction of the original polishing lines.

Ultimately, any stainless part can be restored to a brilliant shine with power buffing processes.

Caution:

Do not use steel wool or any type of metal scraper. Do not use “Scotch Brite” pads or abrasive powdered cleaners. Do not try to clean with muriatic acid or any other acid.

Stainless Fasteners

Stainless steel fasteners are included in many of the stainless kits. These fasteners provide similar corrosion resistance and appearance as the rest of the kit. However, stainless fasteners are prone to galling when installed in similar stainless material. It is a good idea to apply a small amount of anti-seize compound to the threads when installing them. Care should also be taken when tightening the fasteners to prevent rounding or deforming the corners of the bolts. Make sure the wrenches are the correct size and fit properly. In the case of socket heads, the wrench should have sharp, un-worn edges. With a few precautions during assembly the products should provide years of service.

WARNING

PERFORM REGULAR INSPECTIONS ON THE WINCH, WINCH MOUNT, AND RELATED HARDWARE. NEVER OPERATE THE WINCH OR WINCH MOUNT WITH DAMAGED OR MISSING PARTS. FAILURE TO FOLLOW THIS WARNING MAY CAUSE VEHICLE DAMAGE AND OPERATOR INJURY OR DEATH.