



INSTALLATION INSTRUCTIONS

PLOW MOUNTING KIT

PART NUMBER: 82530
APPLICATION: 2006+ BRUTE FORCE 650i

Your safety, and the safety of others, is very important. To help you make informed decisions about safety, we have provided installation and operating instructions and other information on labels and in this guide. This information alerts you to potential hazards that could hurt you or others. It is not possible to warn you about all potential hazards associated with this product, you must use your own good judgment.

CARELESS INSTALLATION AND OPERATION CAN RESULT IN SERIOUS INJURY OR EQUIPMENT DAMAGE. READ AND UNDERSTAND ALL SAFETY PRECAUTIONS AND OPERATING INSTRUCTIONS BEFORE INSTALLING AND OPERATING THIS PRODUCT.

This guide identifies potential hazards and has important safety messages that help you and others avoid personal injury or death. **WARNING** and **CAUTION** are signal words that identify the level of hazard. These signal words mean:

▲WARNING signals a hazard that *could* cause serious injury or death, if you do not follow recommendations. **▲CAUTION** signals a hazard that *may* cause minor to moderate injury, if you do not follow recommendations.

This guide uses **NOTICE** to call attention to important mechanical information, and **Note**: to emphasize general information worthy of special attention.

▲ WARNING

INJURY HAZARD

Failure to observe these instructions could lead to severe injury or death.

- Always** Read the Plow Operator's Manual, the Winch Operator's Manual and all warning labels before operating.
- Always** use extreme caution when drilling on any vehicle. Make sure that all fuel lines, brake lines, electrical wires, and other objects are not punctured or damaged when/if drilling on the vehicle. Thoroughly inspect the area to be drilled (on both sides of material) prior to drilling, and relocate any objects that may be damaged. Failure to inspect the area to be drilled may result in vehicle damage, electrical shock, fire or personal injury.
- Always** wear safety glasses when installing this kit. A drilling operation will cause flying metal chips. Flying chips can cause eye injury.
- Always** use extreme caution when cutting and trimming during fitting.
- Always** remove jewelry and wear eye protection.
- Never** lean over battery while making connections.
- Never route electrical cables:**
 - Across any sharp edges.
 - Through or near moving parts.
 - Near parts that become hot.
- Always** insulate and protect all exposed wiring and electrical terminals.
- Always** install terminal boots as directed in installation instructions.
- Always** use appropriate and adequate care in lifting components into place.
- Always** insure components will remain secure during installation and operation.
- Always** tighten all nuts and bolts securely, per the installation instructions.
- Always** operate the vehicle at a walking speed with the blade installed. Never exceed 5 mph (8 km/h), even with blade up.
- Always** plow cautiously, impact with hidden or stationary object may cause the vehicle to stop suddenly or go out of control.
- Never** operate the vehicle on slopes greater than 10 degrees with the plow installed.
- Never** stand or ride on the plow.
- Always** stay clear of moving parts and joints. Always keep others away when operating or adjusting plow.
- Always** perform regular inspections and maintenance on the plow mechanism, fasteners, cable and related hardware.
- Always** replace all worn or damaged parts before operating.
- Never** operate this WARN product with damaged or missing parts.
- Always** drive slowly over bumpy and rough terrain. Driving at speeds that cause the plow to bounce while in the up position can cause the winch to back-drive, causing the plow to work its way down. This may result in the plow impacting a stationary object and cause damage to the vehicle and operator injury or death.
- Always** drive at speeds such that the plow does not bounce and be aware of the plow position while driving at all times.
- Always** be aware that the purpose of the j-bolt is to break the connection between the plow and the winch, to prevent serious damage to the ATV if the plow is raised too high. The plow blade will drop suddenly if the j-bolt breaks, so always be sure there are no bystanders when you raise and lower the plow.
- Never** raise the top of the plow above the headlights of the ATV, as it may damage the vehicle and plow.
- Always** replace a deformed or broken j-bolt with the spare j-bolt included in the kit.

⚠ CAUTION
Moving Parts Entanglement Hazard
Failure to observe these instructions could lead to minor or moderate injury.
<input type="checkbox"/> Always take time to fully read and understand the installation and Operations Guide included with this product. <input type="checkbox"/> Never operate this product if you are under 16 years of age. <input type="checkbox"/> Never operate this product when under the influence of drugs, alcohol or medications.
Read installation and operating instructions thoroughly.

Notice
Equipment Damage
<p>→ ALWAYS REFER TO THE INSTALLATION AND SPECIFICATION GUIDE, SUPPLIED IN THE WINCH KIT, FOR ALL WIRING SCHEMATICS AND SPECIFIC DETAILS ON HOW TO WIRE THIS WARN PRODUCT TO YOUR VEHICLE.</p> <input type="checkbox"/> Never overtighten the j-bolt to the bracket. Doing so will pinch the winch cable against the bracket, damaging the cable. <input type="checkbox"/> Always put the end of the actuator cable through the slot in the Termination Bracket. Terminating the cable through any other hole in the bracket will cause the bracket to not function properly and will drastically reduce the life of the actuator cable.
Read installation and operating instructions thoroughly.

I. TABLE OF CONTENTS

Tools Required page 2
Torque Specifications page 2
Parts List page 3
Installation page 4-5
Maintenance/Carepage page 6

II. TOOLS REQUIRED

- 3/8" Ratchet and 6" Extension
- Sockets: 10, 13 and 14mm

III. TORQUE SPECIFICATIONS

1/4 (M6)	8 lb. ft. (10.8 N-m)
5/16 (M8)	17 lb. ft. (12.5 N-m)
M8 U-Bolt	11 lb. ft. (15 N-m)

IV. PARTS LIST

<u>Ref.</u>	<u>Part Number</u>	<u>Qty</u>	<u>Description</u>
A1	82573	1	Plow Mount Bracket BF650i
A2	79225	1	Plow Flange Bracket, Left
A3	79226	1	Plow Flange Bracket, Right
A4	82536	1	Bumper Cover Plate BF650i
A5	82537	1	Pan Clamp Plate BF650i
B1	1324	4	Flat Washer 5/16
B2	22491	4	Lock Nut M8
B3	79604	2	M8 U-Bolt 35x48 mm
B4	79461	2	Bolt M10-1.25x20 Hex
C1	79712	2	Retaining Pin Plow L-Wire

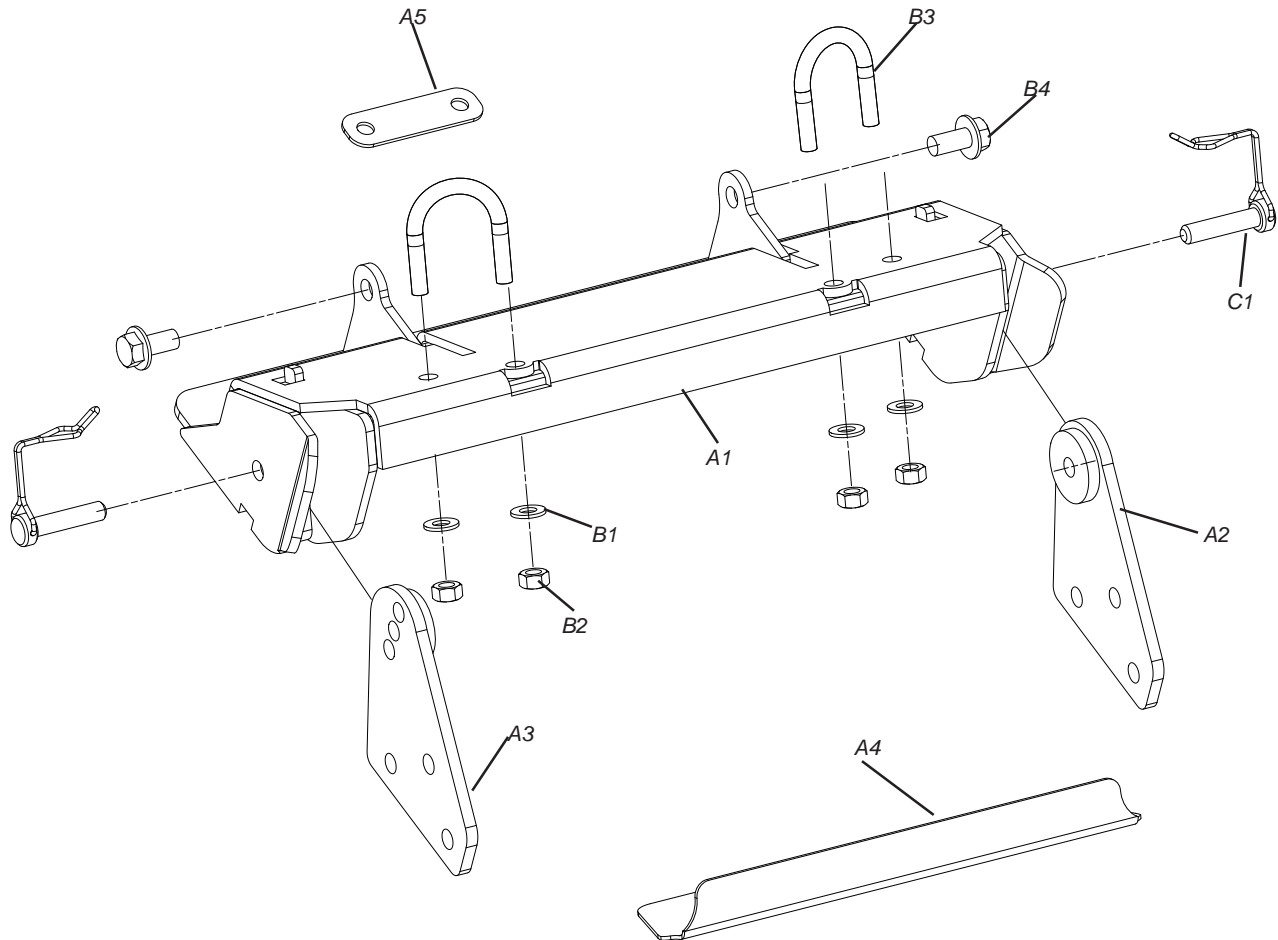

V. INSTALLATION

Remove Front Skid Pan

1. Use 10mm socket to remove the M6 flange head screws that secure the front pan to bumper and frame. (Figure 1)
2. Install the small skid pan clamp (Figure 2) plate to secure the front of the bottom skid pan. Secure this plate and the skid pan with the original M6 factory fasteners.

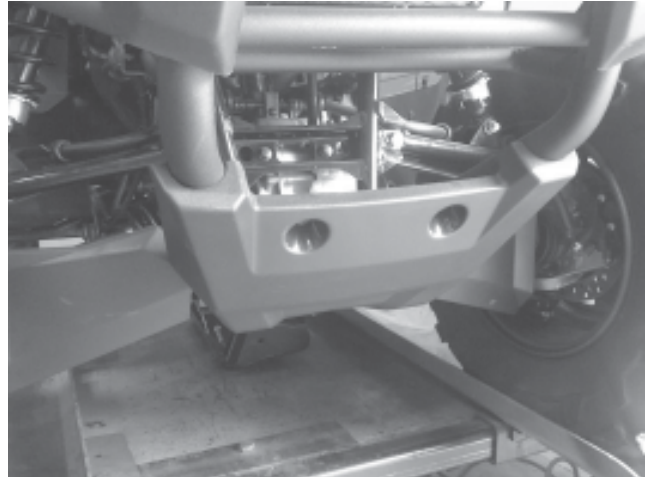

Figure 1

Install Plow Mount

1. Use 14mm socket to remove the M10 factory bumper bolts. (Figure 3).
2. The upper bumper bolts may need to be loose to allow the lower bolts to be removed and reinstalled.
3. Position Plow Mount on front bumper (Figure 4). Use M10-1.25x20mm bolts provided to secure the mount at frame.
4. Position M8 U-Bolts over bumper tubes and insert into mount. (Figure 5).
5. Secure U-Bolts with M8 lock nuts.



Figure 2

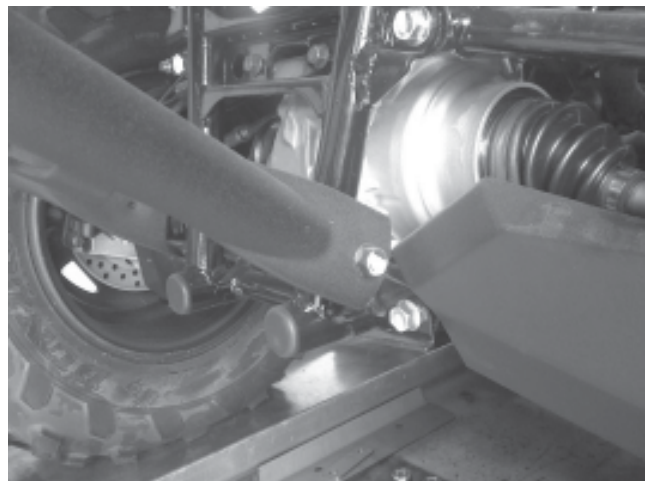

Figure 3

INSTALLATION CONT.

Install Bumper Cover Plate

1. The small formed plate included in this kit is intended to cover the front bumper skid pan mounting tabs.
2. Position it on the mounting tabs, as shown in Figure 6 and secure it with the original factory fasteners.



Figure 4



Figure 5

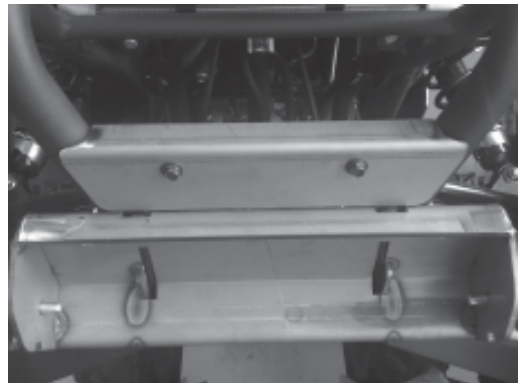

Figure 6

Install the plow mounting tabs.

1. The plow mounting tabs supplied in this kit must be secure to the plow in the position shown. (Figure 7).
2. Loosely install the M10 bolts from the plow kit. Attach the plow to the plow mount and then secure the plow mounting tabs. This will insure the best fit for your vehicle.



Figure 7

VI. MAINTENANCE/CARE

- Inspect all metal parts on the plow, plow mount, and related hardware. Replace all parts that appears rusted or deformed prior to use.
- Inspect all nuts and bolts on the plow, plow mount, and related hardware prior to each use. Tighten all nuts and bolts that appear to be loose. Stripped, fractured, or bent bolts or nuts need to be replaced immediately.
- Check all cables prior to use. Replace cables that are worn or frayed.
- Check all moving and rotating parts. Remove debris that may inhibit the part from moving freely.