



INSTALLATION INSTRUCTIONS

WINCH MOUNTING KIT

Part Number: 87355

Application: Polaris 2011+ 400, 500, 800

GENERAL SAFETY PRECAUTIONS

Your safety, and the safety of others, is very important. To help you make informed decisions about safety, we have provided installation and operating instructions and other information on labels and in this guide. This information alerts you to potential hazards that could hurt you or others. It is not possible to warn you about all potential hazards associated with this product, you must use your own good judgment.

CARELESS INSTALLATION AND OPERATION CAN RESULT IN SERIOUS INJURY OR EQUIPMENT DAMAGE. READ AND UNDERSTAND ALL SAFETY PRECAUTIONS AND OPERATING INSTRUCTIONS BEFORE INSTALLING AND OPERATING THIS PRODUCT.

This guide identifies potential hazards and has important safety messages that help you and others avoid personal injury or death. **WARNING** and **CAUTION** are signal words that identify the level of hazard. These signal words mean:

▲ **WARNING** signals a hazard that could cause serious injury or death, if you do not follow recommendations. ▲ **CAUTION** signals a hazard that may cause minor to moderate injury, if you do not follow recommendations.

This guide uses **NOTICE** to call attention to important mechanical information, and **Note:** to emphasize general information worthy of special attention.

▲ WARNING

IMPACT AND MOVING PARTS ENTANGLEMENT HAZARD

Failure to observe these instructions could lead to severe injury or death

- Always use extreme caution when drilling on any vehicle. Make sure that all fuel lines, brake lines, electrical wires, and other objects are not punctured or damaged when / if drilling on the vehicle. Thoroughly inspect the area to be drilled (on both sides of material) prior to drilling, and relocate any objects that may be damaged. Failure to inspect the area to be drilled may result in vehicle damage, electrical shock, fire or personal injury.
- Always wear safety glasses when installing this kit. A drilling operation will cause flying metal chips. Flying chips can cause eye injury.
- Always use extreme caution when cutting and trimming during fitting.
- Always remove jewelry and wear eye protection.
- Never lean over battery while making connections.
- Never route electrical cables:
 - Across any sharp edges.
 - Through or near moving parts.
 - Near parts that become hot.
- Always insulate and protect all exposed wiring and electrical terminals.
- Always install terminal boots as directed in installation instructions.
- Always use appropriate and adequate care in lifting components into place.
- Always insure components will remain secure during installation and operation.
- Always tighten all nuts and bolts securely, per the installation and operation.
- Always perform regular inspections and maintenance on the winch, winch mount and related hardware.

Read installation and operating instructions thoroughly.

WARN INDUSTRIES, INC. 12900 S.E. Capps Road,
Clackamas, OR USA 97015-8903, 1-503-722-1200, FAX: 1-503-722-3000
Customer Service: 1-800-543-9276
Dealer Locator Service: 1-800-910-1122
International Sales/Customer Service: 1-503-722-3008
International Fax: 1-503-722-3005

⚠ CAUTION

MOVING PARTS ENTANGLEMENT HAZARD

Failure to observe these instructions could lead to minor or moderate injury

- Always take time to fully read and understand the installation and Operations Guide included with this product.
- Never operate this product if you are under 16 years of age.
- Never operate this product when under the influence of drugs, alcohol or medications.

Read installation and operating instructions thoroughly.

NOTICE

EQUIPMENT DAMAGE

- Always refer to the Installation and Specification Guide, supplied in the winch kit, for all wiring schematics and specific details on how to wire this WARN product to your vehicle.
- Never overtighten the j-bolt to the bracket. Doing so will pinch the winch cable against the bracket, damaging the cable.
- Always put the end of the actuator cable through the slot in the Termination Bracket. Terminating the cable through any other hole in the bracket will cause the bracket to not function properly and will drastically reduce the life of the actuator cable.

Read installation and operating instructions thoroughly.

NOTES

BEFORE YOU BEGIN

TABLE OF CONTENTS

Parts List..... page 3
 Tools Required..... page 3
 Torque Specifications..... page 3
 Installation..... page 4-7

PARTS LIST

<u>Ref.</u>	<u>Description</u>	<u>Qty.</u>
A1	Winch Mounting Plate Sportsman	1
A2	Spacer Winch Sportsman	2
B1	Lock Washer	4
B2	M8 x 30mm Bolt	4

TOOLS REQUIRED

- Ratchet
- Metric socket set
- Metric wrench set
- Hacksaw blade or dremel to cut plastic
- Torque drive bits

TORQUE SPECIFICATIONS

1/4 (6mm)	8 lb. ft. (10.8 N-m)
5/16 (8mm)	17 lb. ft. (12.5 N-m)
3/8 (10mm)	30 lb. ft. (40.7 N-m)
7/16 (11mm)	50 lb. ft. (67.8 N-m)
1/2 (13mm)	75 lb. ft. (101.7 N-m)

INSTALLATION INSTRUCTIONS

⚠ WARNING

IMPACT AND MOVING PARTS ENTANGLEMENT HAZARD

Failure to observe these instructions could lead to severe injury or death

- Always use extreme caution when drilling on any vehicle. Make sure that all fuel lines, brake lines, electrical wires, and other objects are not punctured or damaged when / if drilling on the vehicle. Thoroughly inspect the area to be drilled (on both sides of material) prior to drilling, and relocate any objects that may be damaged. Failure to inspect the area to be drilled may result in vehicle damage, electrical shock, fire or personal injury.
- Always remove jewelry and wear eye protection.

Read installation and operating instructions thoroughly.

1. Remove winch Tie Bolt

The Tie Bolt at the bottom of the winch must be removed before installation on winch mounting plate. (Figure 1) Use a Phillips head screwdriver to remove this screw. Never operate the winch without the bottom tie bolt or a winch mounting plate installed. These parts insure that the drum supports are evenly spaced at the top and bottom.

2. Install winch in Mount

Fairlead mounting bolts must be placed in mounting plate before installing winch. Secure the winch to the mounting plate with the M8 bolts supplied with your winch. The shim plates shown in Figure 2 must be installed as shown. The longer M8 mounting bolts must be installed in the drum support attached to the motor. See your winch installation instructions for complete instructions. Be sure to torque the M8 mounting bolts to the specification in winch installation instruction.

3. Install Fairlead on Mount

The fairlead mounting bolts must be installed from the inside of the mounting plate as shown in Figure 3.

Use the roller fairlead hardware supplied with the winch to secure the roller fairlead.

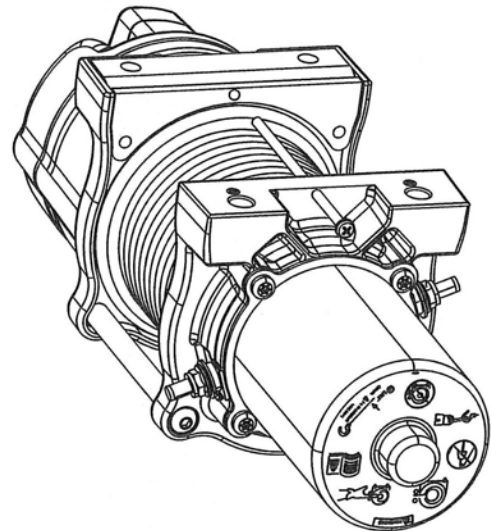

Figure 1

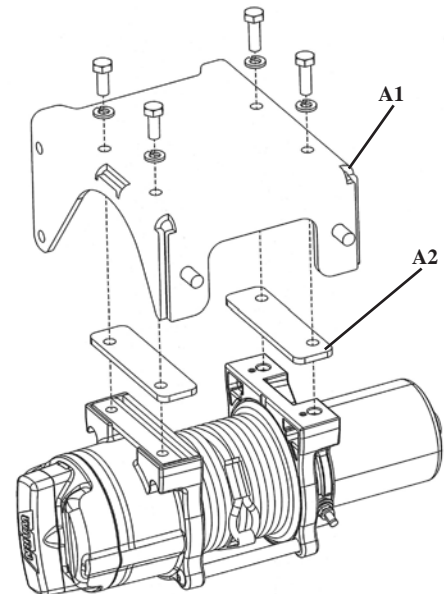

Figure 2

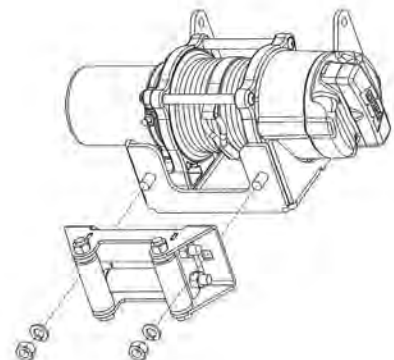

Figure 3

INSTALLATION INSTRUCTIONS

4. Install wires on Winch

The Yellow and Blue winch wires must be installed on Winch before mounting to vehicle.

The motor terminals are color coded. Install both wires with a boot as shown in Figure 4. See winch installation instruction for terminal nut torque specification.



Figure 4

5. Remove Front Lower Bumper

Remove the four bolts securing the lower bumper section to the frame.

Figure 5 shows frame with lower bumper plastic removed.



Figure 5 A



Figure 5 B

INSTALLATION INSTRUCTIONS

6. Install Winch and Mount on Frame

Pull the winch wires up into the frame so that the winch and mount can be secured to the frame as shown in Figure 6.



Figure 6

Secure the winch and mount to the frame with the M8 x 30mm bolts, washers, lock washers nuts as shown in Figure 7.

Install the rope hook and strap that were supplied with the winch kit.

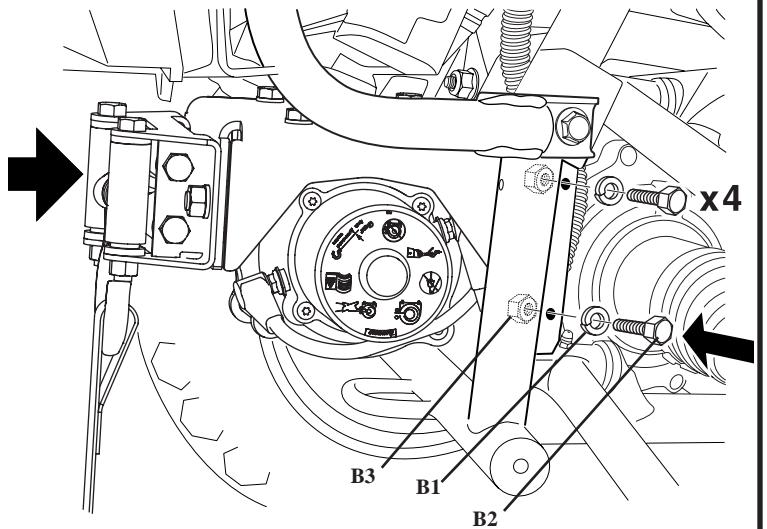

Figure 7

⚠ WARNING

IMPACT AND MOVING PARTS ENTANGLEMENT HAZARD

Failure to observe these instructions could lead to severe injury or death

- Never lean over battery while making connections.
- Never route electrical cables:
 - Across any sharp edges.
 - Through or near moving parts.
 - Near parts that become hot.
- Always insulate and protect all exposed wiring and electrical terminals.
- Always install terminal boots as directed in installation instructions.

Read installation and operating instructions thoroughly.

7. Route Winch Wires to Contactor

See your winch installation instructions for details on routing the electrical wires to the contactor.

Be sure to secure the wires with electrical ties to the frame.

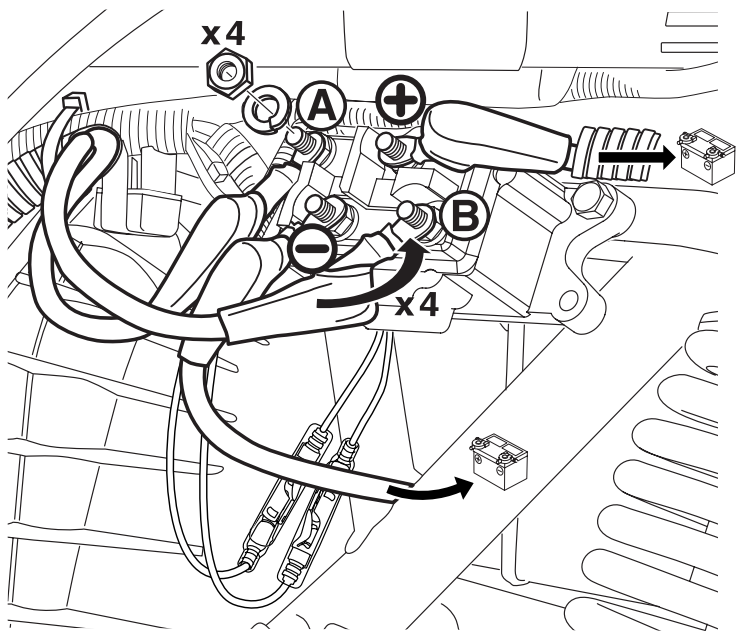

Figure 8

INSTALLATION INSTRUCTIONS

8. Install Contactor in Left Rear Wheelwell

Install the contactor in the front right wheelwell as shown in Figure 9. Secure the contactor to the tray with the hardware supplied with the winch.

For ease in installation, remove the two screws that hold the tray before mounting the solenoid.

Secure the winch wires to the contactor with electrical boots installed to protect terminals.

Secure the battery wires to the contactor with electrical boots to protect the terminals.

9. Route Battery Wires to Battery

Route the battery wires from the contactor to the battery.

Install the winch control switch per the winch installation instructions.

10. Connect the battery wires to the battery.

Secure all wires making sure that they do not come in contact with any sharp edges or surfaces that will become hot.

11. Reinstall front lower bumper.

Following the perforated marks in the molded plastic, use a hacksaw or dremel tool, to trim the center of the plastic out. Reinstall the lower section of the front bumper.

Review the winch installation instructions to complete the installation of the winch.



Figure 9



Figure 10

⚠ WARNING

FAILURE TO SECURELY TIGHTEN ALL BOLTS ON THE WINCH PLATE, WINCH, AND FAIRLEAD CAN RESULT IN PRODUCT FAILURE WHICH MAY RESULT IN VEHICLE DAMAGE AND OPERATOR INJURY OR DEATH. DOUBLE CHECK THAT ALL BOLTS ARE SECURELY TIGHTENED PRIOR TO USE.

NOTICE

IT SHOULD BE NOTED THAT THE FOLLOWING INSTRUCTIONS ARE UNIT SPECIFIC. THE FOLLOWING INSTRUCTIONS SHOULD BE REFERRED TO AS REFERENCE INSTRUCTIONS TO ASSIST WIRING THE WINCH FROM THE INSTALLATION AND SPECIFICATION GUIDE SUPPLIED IN THE WINCH KIT.



Figure 11