



INSTALLATION INSTRUCTIONS

A-Arm Guards, Rear

Part Number: 88342

Application: 2012+ Kawasaki Brute Force 750 4x4i

GENERAL SAFETY PRECAUTIONS

Your safety, and the safety of others, is very important. To help you make informed decisions about safety, we have provided installation and operating instructions and other information on labels and in this guide. This information alerts you to potential hazards that could hurt you or others. It is not possible to warn you about all potential hazards associated with this product, you must use your own good judgment.

CARELESS INSTALLATION AND OPERATION CAN RESULT IN SERIOUS INJURY OR EQUIPMENT DAMAGE. READ AND UNDERSTAND ALL SAFETY PRECAUTIONS AND OPERATING INSTRUCTIONS BEFORE INSTALLING AND OPERATING THIS PRODUCT.

This guide identifies potential hazards and has important safety messages that help you and others avoid personal injury or death. **WARNING** and **CAUTION** are signal words that identify the level of hazard. These signal words mean:

▲ **WARNING** signals a hazard that could cause serious injury or death, if you do not follow recommendations. ▲ **CAUTION** signals a hazard that may cause minor to moderate injury, if you do not follow recommendations.

This guide uses **NOTICE** to call attention to important mechanical information, and **Note:** to emphasize general information worthy of special attention.

▲ WARNING

Impact and Moving Parts Entanglement Hazard

FAILURE TO OBSERVE THESE INSTRUCTIONS COULD LEAD TO SEVERE INJURY OR DEATH

- Always use extreme caution when drilling on any vehicle. Make sure that all fuel lines, brake lines, electrical wires, and other objects are not punctured or damaged when / if drilling on the vehicle. Thoroughly inspect the area to be drilled (on both sides of material) prior to drilling, and relocate any objects that may be damaged. Failure to inspect the area to be drilled may result in vehicle damage, electrical shock, fire or personal injury.
- Always wear safety glasses when installing this kit. A drilling operation will cause flying metal chips. Flying chips can cause eye injury.
- Always use extreme caution when cutting and trimming during fitting.
- Always remove jewelry and wear eye protection.
- Always insure components will remain secure during installation and operation.
- Always tighten all nuts and bolts securely, per the installation and operation.
- Always perform regular inspections and maintenance on the winch, winch mount and related hardware.
- Always replace all worn or damaged parts before operating.
- Never operate this WARN product with damaged or missing parts.
- Never work under vehicle before properly securing vehicle.

Read installation and operating instructions thoroughly.

WARN INDUSTRIES, INC. 12900 S.E. Capps Road,
 Clackamas, OR USA 97015-8903, 1-503-722-1200, FAX: 1-503-722-3000
Customer Service: 1-800-543-9276
Dealer Locator Service: 1-800-910-1122
International Sales/ Customer Service: 1-503-722-3008
International Fax: 1-503-722-3005

⚠ CAUTION

Moving Parts Entanglement Hazard

FAILURE TO OBSERVE THESE INSTRUCTIONS COULD LEAD TO MINOR OR MODERATE INJURY

- Always take time to fully read and understand the installation and Operations Guide included with this product.
- Never operate this product if you are under 16 years of age.
- Never operate this product when under the influence of drugs, alcohol or medications.

Read installation and operating instructions thoroughly.

NOTICE

Equipment Damage

- Always refer to the Installation and Specification Guide, supplied in the winch kit, for all wiring schematics and specific details on how to wire this WARN product to your vehicle.
- Product may affect airflow to vehicle engine and drivetrain components.
- Installation of this accessory may affect vehicle warranty.
- This product will NOT protect vehicle from all impacts and terrain conditions.

Read installation and operating instructions thoroughly.

TABLE OF CONTENTS

Tools Required.....	page 2
Torque Specifications.....	page 2
Parts List.....	page 3
Installation.....	page 4-5

TOOLS REQUIRED

- 8, 10mm socket
- 4mm hex wrench
- Philips screwdriver

TORQUE SPECIFICATIONS

M6 8 lb. ft. (10.8 N-m)

BEFORE YOU BEGIN

Installation tip:

- Apply electrical tape to clean dry vehicle components that will be in direct contact with aluminum skid plates. Tape will help protect painted finish against abrasion and can reduce tendency of squeaks.
- Raising the vehicle on a hoist or ramps may ease installation of this product.

PARTS LIST

Reference	Part Number	Qty	Description
A1	76302	1	LH Guard
A2	76303	1	RH Guard
A3	88192	1	LH Inner Bracket
A4	88193	1	RH Inner Bracket
A5	88336	1	LH Outer Bracket
A6	88337	1	RH Outer Bracket
B1	1320	8	Washer
B2	60595	8	M6 Locknut
B3	77125	8	M6 Screw

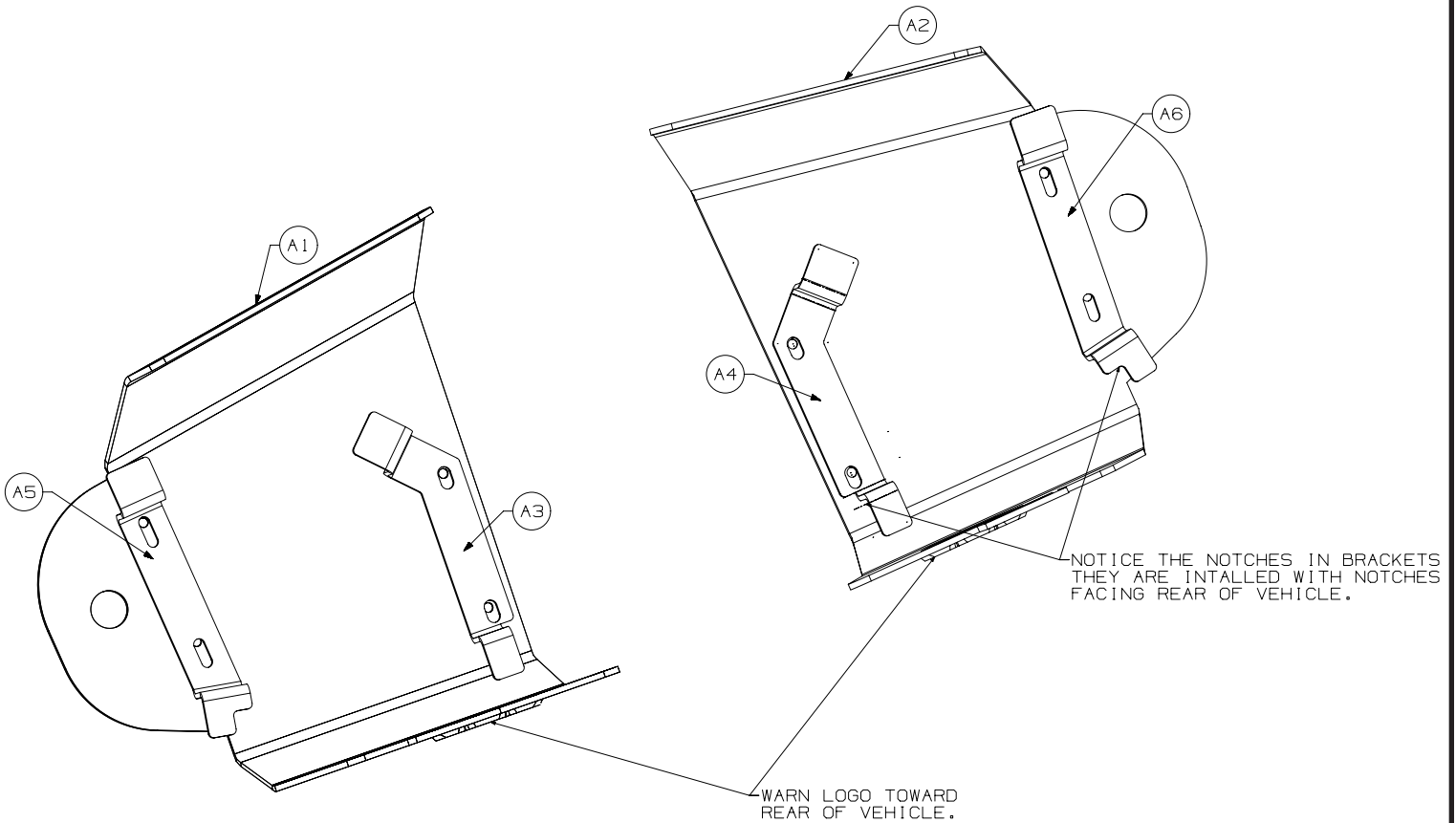

INSTALLATION INSTRUCTIONS

⚠ WARNING

Impact and Moving Parts Entanglement Hazard

FAILURE TO OBSERVE THESE INSTRUCTIONS COULD LEAD TO SEVERE INJURY OR DEATH

- Always wear safety glasses when installing this kit. A drilling operation will cause flying metal chips. Flying chips can cause eye injury.

Read installation and operating instructions thoroughly.

1. Remove factory rear a-arm guards, if applicable.

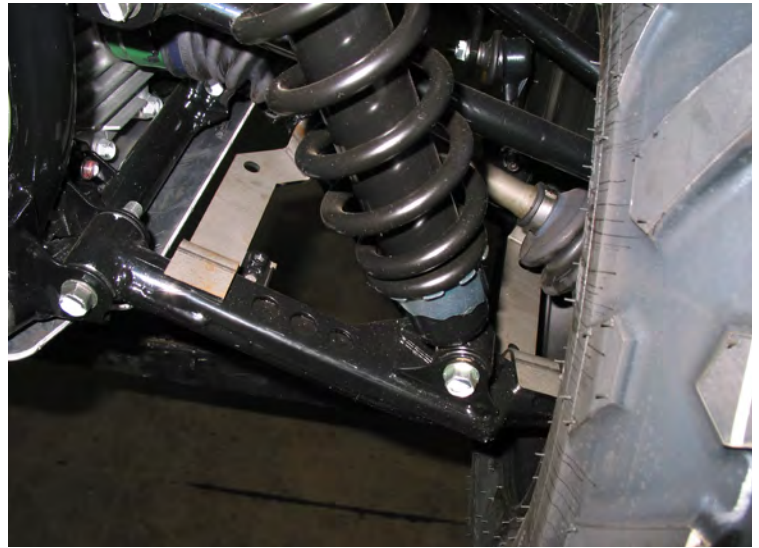

Figure 1

2. Place brackets(A4 and A6) on top of lower A-arm. See Figure 1.

3. Place A-arm guard (A2) into position on A-arm. See Figure 2.



Figure 2

Install M6 Screws (B3) through guard and brackets. Fasten with washer (B1) and lock nuts (B2). See Figure 3.

4. Align guard as needed. Tighten all fasteners to torque specification listed above.
5. Repeat steps one through four for installing guard (A1) on other A-Arm.

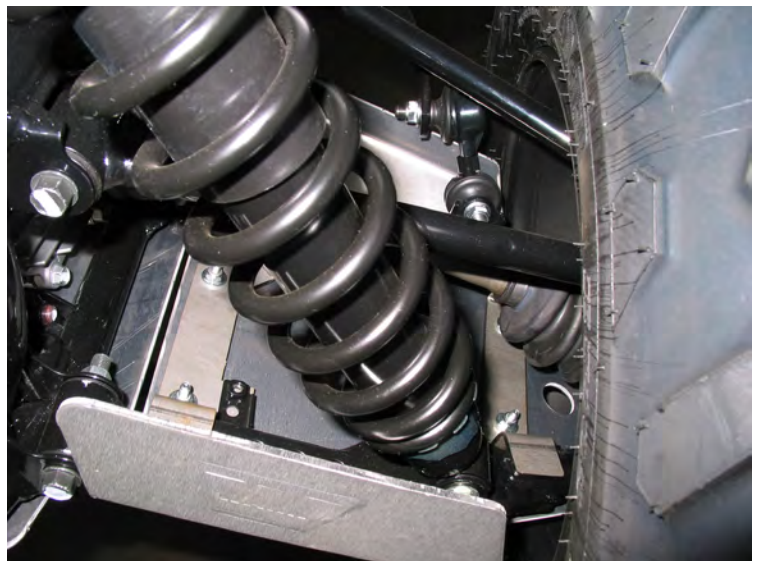

Figure 3



Figure 4

CARELESS INSTALLATION AND OPERATION CAN RESULT IN SERIOUS INJURY OR EQUIPMENT DAMAGE. READ AND UNDERSTAND ALL SAFETY PRECAUTIONS AND OPERATING INSTRUCTIONS BEFORE INSTALLING AND OPERATING THIS PRODUCT.

