

Warn Industries, Inc.

12900 S.E. Capps Road

Clackamas, OR USA 97015-8903

1-503-722-1200 FAX: 1-503-722-3000

www.warn.com

Customer Service / Service Clients: 1-800-543-9276

International Sales Support / Les Ventes internationales

Soutien: 1-503-722-3005

© 2012 Warn Industries, Inc.
WARN®, the WARN logo are registered trademarks of Warn Industries, Inc.
WARN® et le logo WARN sont des marques déposées de Warn Industries, Inc.



(31”) ZEON CONTROL PACK RELOCATION KIT

**INSTALLATION GUIDE
GUIDE D'INSTALLATION**

English 1



Zeon Control Pack Relocation Kit

31" Cable Length

Every winching situation has the potential for personal injury. In order to minimize that risk, it is important to read this guide and The Basic Guide to Winching Techniques carefully. Please familiarize yourself with the operation of your winch before using it and be constantly safety oriented. In this guide we provide important safety information and instructions on how to install your Control Pack Relocation Kit. Please read the Basic Guide to Winching Techniques for information on how to properly use your winch and proper rigging techniques.

Please keep this manual and other product literature found in this kit for future reference. Should you be missing any of the necessary instructions, please visit www.warn.com or contact us at the number below.

TABLE OF CONTENTS:

SAFETY

Symbol Index2
 General Safety Precautions3

INSTRUCTIONS

Before you Begin4
 Parts List4
 Tools Required5
 Torque Specifications5
 Installation Instructions6-9
 Remove Control Pack From Winch6-7
 Installing Relocation Cables7
 Relocating the Control Pack8
 Connecting the Contactor9
 Mounting Hole Drill Template 10

Warn Industries Inc.
 12900 SE Capps Road
 Clackamas, OR 97015
 USA

Customer Service: (800) 543-9276
 International Fax: (503) 722-3005
 Fax: (503) 722-3000
www.warn.com

WARN® and the WARN logo are registered trademarks of Warn Industries, Inc.
 © 2012 Warn Industries, Inc.

SYMBOL INDEX

SYMBOL	EXPLANATION
	Read All Product Literature
	Always Wear Hearing and Eye Protection
	Never Use Winch as a Hoist
	Finger/Fairlead Crushing Hazard
	Hand Piercing/Cutting Hazard
	Explosion/Bursting Hazard
	Never Route Electrical Cables through Sharp Edges Hazard
	Avoid Installing Electrical Cables around Pinch and Wear/Abrasion Points

SYMBOL	EXPLANATION
	Always Wear Leather Gloves
	Do Not Move People
	Always Use Supplied Hook Strap
	Fairlead Pinch Point
	Hot Surface Hazard
	Fire and Burn Hazard
	Never Route Electrical Cables through or near Moving Parts Hazard
	Exposed Wiring Hazard, Insulate Exposed Wiring and Terminals
	Never Hook Back on Rope

Warnings and Cautions



As you read these instructions, you will see WARNINGS, CAUTIONS, NOTICES and NOTES. Each message has a specific purpose. WARNINGS are safety messages that indicate a potentially hazardous situation, which, if not avoided could result in serious injury or death. CAUTIONS are safety messages that indicate a potentially hazardous situation which, if not avoided, could result in minor or moderate injury. A CAUTION may also be used to alert against unsafe practice. CAUTIONS and WARNINGS identify the hazard, indicate how to avoid the hazard, and advise of the probable consequence of not avoiding the hazard. NOTICES are messages to avoid property damage. NOTES are additional information to help you complete a procedure. **PLEASE WORK SAFELY!**

! WARNING

CHEMICAL AND FIRE HAZARD

Failure to observe these instructions could lead to serious injury or death.

- **Always** remove jewelry and wear eye protection.
- **Never** route electrical cables across sharp edges.
- **Never** route electrical cables near parts that get hot.
- **Never** route electrical cables through or near moving parts.
- **Always** place the supplied terminal boots on wires and terminals as directed by the installation instructions.
- **Never** lean over battery while making connections.
- **Never** route electrical cables over battery terminals.
- **Never** short battery terminals with metal objects.
- **Always** verify area is clear of fuel lines, fuel tank, brake lines, electrical wires, etc., when drilling.
- **Always** consult operator's manual for proper wiring details.
- **Always** insulate and protect all exposed wiring and electrical terminals.
- **Never** mount contactor with electrical terminals touching metal objects.

! CAUTION

MOVING PARTS ENTANGLEMENT HAZARD

Failure to observe these instructions could lead to minor or moderate injury.

To avoid injury to hands or fingers:

- **Never** leave remote control where it can be activated during free spooling, rigging, or when the winch is not being used.
- **Never** leave the winch remote control plugged in when installing, freespooling, rigging, servicing or when the winch is not being used.

! WARNING

MOVING PARTS ENTANGLEMENT HAZARD

Failure to observe these instructions could lead to serious injury or death.

General Safety:

- **Always** Know Your Winch. Take time to fully read the Instructions and/or Operations Guide, and/or Basic Guide to Winching Techniques, in order to understand your winch and its operations.
- **Always** keep wired remote control lead and power cord clear of the drum, rope, and rigging. Inspect for cracks, pinches, frayed wires or loose connections. Damaged components must be replaced before operation.

! WARNING

FALLING OR CRUSHING HAZARD

Failure to observe these instructions could lead to serious injury or death.

- **Always** stand clear, keep hands clear, keep others away.

Please familiarize yourself with the components.

- Mounting Kit PN89970: Includes a mounting bracket and all needed hardware to mount your kit.
- Mounting Kit PN89965: Does not include a mounting bracket and you will need to purchase some additional hardware to complete mounting*.
- Bracket Kit PN89770 is available for purchase if you later decide to use a bracket for mounting. Contact a Warn Industries customer service representative at 1.800.543.9276.

Parts List

Description	Qty	Part Number
31" Wire Assembly Kit with Mounting Bracket		89970
31" Cable Assembly	1	89663
Wire housing top	1	89372
M4 screw	2	64503
Butt splice	1	85978
31" ground extension	1	89963
Bracket	1	89729
M6 bolt	4	86346
M6 lock washer	4	77009
5/16" bolt	4	21331
5/16" washer	8	1324
5/16" lock nut	4	2002

Description	Qty	Part Number
31" Wire Assembly Kit without Mounting Bracket*		89965
31" Wire Assembly	1	89663
Wire housing top	1	89372
M4 screw	2	64503
Butt splice (18 AWG)	1	85978
31" ground extension	1	89963
*M6 bolt needed	4	NOT INCLUDED IN KIT
*M6 lock washer needed	4	NOT INCLUDED IN KIT

OPTIONAL BRACKET KIT -- SOLD SEPARATELY		
Description	Qty	Part Number
Bracket Kit		89770
Bracket	1	89729
M6 Bolt	4	86346
M6 Lock Washer	4	77009
5/16" Bolt	4	21331
5/6" Washer	8	1324
5/16" Lock Nut	4	2002

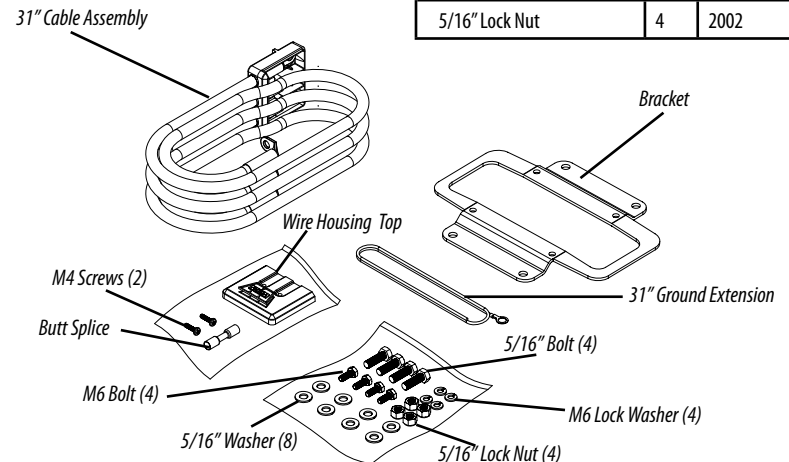

*** NOTE: Four (4) M6 bolts and four (4) M6 lock washers must be purchased separately in order to complete installation without use of bracket.**

BEFORE YOU BEGIN

Tools Required

- Torx Driver Set
- Ratchet/Wrench Set (Standard/Metric)
- Drill and Drill Bit Set
- Wire Cutters
- Wire Strippers/Wire Crimps
- Torque Wrench (30 lb. ft. capacity)
- Zip Ties
- Cable Protection (i.e., flexible electrical conduit or electrical tape)

Torque Specifications

Please use the recommended torque specifications when assembling this product unless otherwise specified in the instructions.

FASTENER SIZE (Grade 5)	FASTENER TORQUE		FASTENER SIZE (Class 8.8)	FASTENER TORQUE	
	lb-ft	(N.m)		lb-ft	(N.m)
1/4"	8	(11)	M4	(2)	3
5/16"	17	(23)	M5	(4.5)	6
3/8"	30	(40)	M6	(7.5)	10
7/16"	48	(66)	M8	(18)	25
1/2"	74	(100)	M10	(37)	50
9/16"	106	(144)			
5/8"	148	(200)			
3/4"	269	(364)			

Inspect all nuts and bolts on all related hardware periodically. Tighten all nuts that appear to be loose. Stripped, fractured, or bent bolts or nuts need to be replaced.

INSTALLATION INSTRUCTION

REMOVE CONTROL PACK FROM WINCH

⚠ WARNING To prevent serious injury or death. Always place the supplied terminal boots on wires and terminals as directed by the installation instructions.

⚠ WARNING To prevent serious injury or death from electrical fire:



Never route electrical cables across sharp edges.



Never route electrical cables near parts that get hot.



Never route electrical cables through or near moving parts.



Avoid pinch and wear/abrasion points when installing all electrical cables.

⚠ WARNING Always insulate and protect all exposed wiring and electrical terminals.

1. Disconnect the vehicle battery cables, negative terminal first. All work with electrical wires and cables must be completed with the battery completely disconnected from the vehicle wiring.
2. Disconnect the ground cable on the under side of the winch (see Figure 1). Make sure the small black wire that connects to the control pack is disconnected and hanging freely.
3. Remove the top buss bar cover by unscrewing the fastener holding it in place. Retain fastener for later use.
4. Remove the three motor terminal nuts and lock washers that secure the buss bars to the motor. Retain the terminal nuts and lock washers for future step.
5. Remove the four (4) flat head torx drive screws located on the underside of the tie plate. NOTE: Rope may need to be spooled out to complete this step.

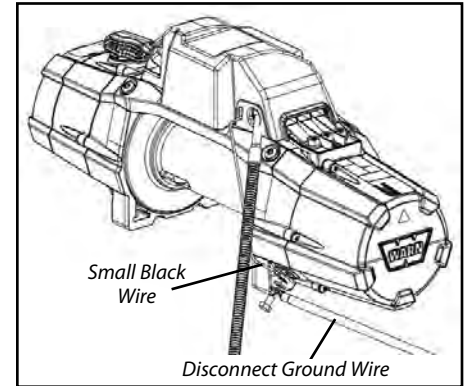

Figure 1

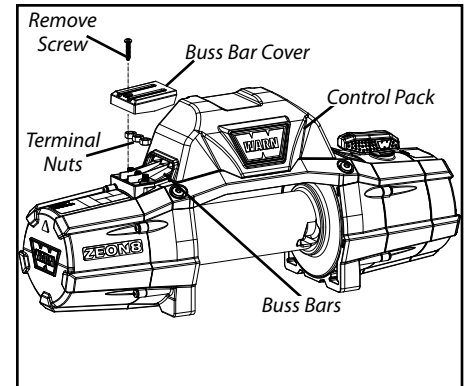

Figure 2

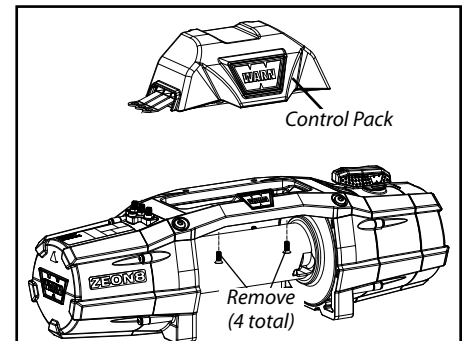

Figure 3

INSTALLATION INSTRUCTION

- Once all four (4) control pack screws have been removed, gently lift the control pack off of the tie plate and set aside to be further disassembled.
- Remove the motor terminal buss bar insulator after control pack has been removed.

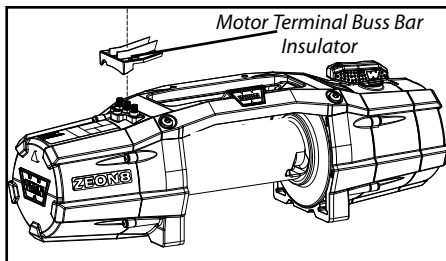

Figure 4

INSTALLING RELOCATION CABLES

- Disassemble the control pack by removing the four (4) flat head torx drive screws.
- Gently lift the control pack cover off of the contactor plate assembly. The cover should remain wired to the contactor during this assembly process. Simply move the cover to one side or out of the way while working on the contactor. This cover will be reinstalled.

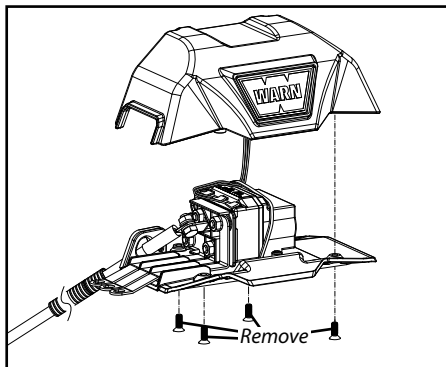

Figure 5

- Remove terminal nuts and lock washers securing the three buss bars to the contactor (see Figure 6). Set aside terminal nuts and lock washers, as they will be used later on. Buss bars will not be used for new installation.

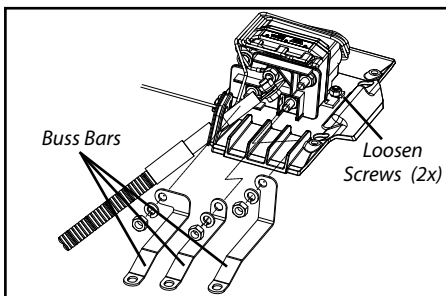

Figure 6

- Loosen the two flat head torx drive screws securing the contactor to the contactor plate. Only loosen. Do not remove.

- Using the terminal nuts and lock washers removed in previous step, connect the labeled cables (A, F1 and F2) to corresponding contactor terminal. Torque nuts to 8.5 - 9 N-m (75-80 in. lb.). Refer to Figure 7.

- Tighten the two flat head torx drive screws and nuts used to secure the contactor to the contactor plate. Secure fasteners to specified torque requirements in torque specification chart found in these instructions.

- Once the cables have been installed, reinstall the cover using the four (4) flat head torx drive screws previously removed. Refer to the torque section of this document.

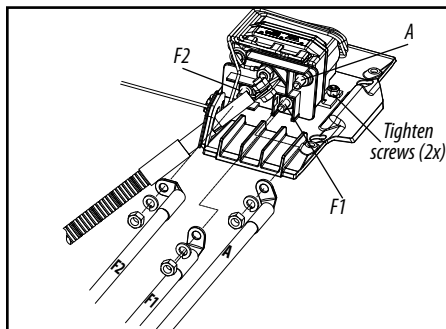

Figure 7

INSTALLATION INSTRUCTION

RELOCATING THE CONTROL PACK

WARNING To prevent serious injury or death from electrical fire:

- Never route electrical cables across sharp edges.
- Never route electrical cables near parts that get hot.
- Never route electrical cables through or near moving parts.
- Avoid pinch and wear/abrasion points when installing all electrical cables.

- (Optional) Depending on your specific relocation kit, you can attach the shown bracket, for easier mounting, using the supplied hex head bolts and lock washers. If you would like to purchase the bracket shown please contact: WARN Industries at 1-800-543-9276 or visit www.warn.com.

- Find an appropriate mounting location to mount the control pack. Make sure to check that the cables and ground wire can be routed to the winch and that the control pack is easily accessible and on a solid mounting surface.

WARNING Always verify area is clear of fuel lines, fuel tank, brake lines, electrical wires, etc., when drilling.

WARNING Never mount contactor with electrical terminals touching metal objects.

- If using the mounting bracket, match drill the 5/16" holes in the bracket to the mounting surface you choose to mount your control pack to. Be sure to check the area before you drill to avoid hitting any electrical cables or gas lines. If opting not to use the mounting bracket, you can use the attached template as a guide for drilling mounting holes. Holes should be drilled to 6.5mm diameter.

- Mount the bracket using the supplied 5/16" bolts with two (2) flat washers and nylock nuts as shown. If opting not to use the mounting bracket, M6 screws and lock washers must be purchased separately to complete this installation.

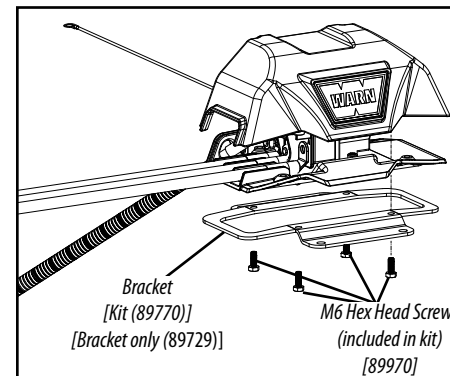

Figure 8

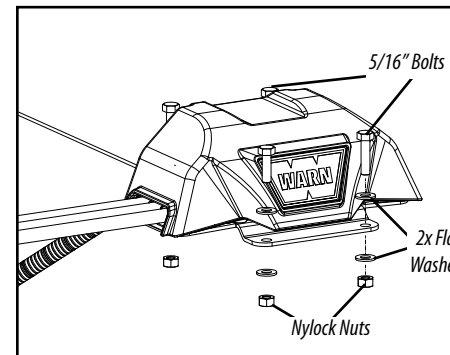

Figure 9

INSTALLATION INSTRUCTION

CONNECTING THE CONTROL PACK

⚠ WARNING Loose or unsecured power cables can cause serious injury or death.

1. Attach the wire terminal housing to the motor terminals on the winch using terminal nuts and lock washer previously removed.
2. Install the cover plate and fasten with the two supplied machine screws. Do not over tighten screws, over tightening could damage the plastic components.

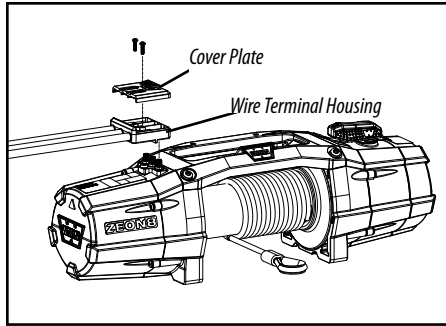

Figure 10

3. Use the supplied butt splice connector and the black extension wire to lengthen the contactor ground wire (see Figure 11).
4. Reconnect the ground cable and small black wire to winch motor ground. Ensure the ground wire is securely fastened. *Secure fasteners to specified torque requirements in torque specification chart found in these instructions.*

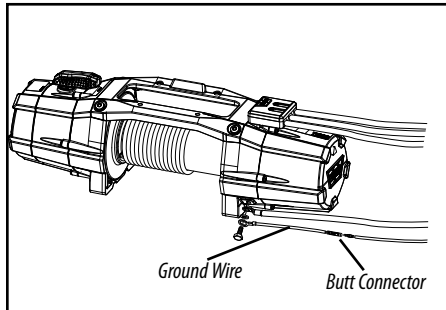

Figure 11

5. Carefully inspect electrical cable routing. Is it neat and tidy? Zip tie and secure electrical cables. Zip ties should be snug, but not cutting into wire insulation. Use electrical tape, pieces of rubber hose or electrical conduit to protect electrical cables and wire harness where needed to avoid electrical cable insulation wear or abrasion.
6. Attach battery cables, red (positive) cable FIRST, black (negative) second. Install boots as appropriate to protect connections. Torque battery terminal fasteners as directed by vehicle service manual.
7. Make sure to plug in the winch remote and ensure that drum is turning in the proper direction when spooling in/out before using in the field.

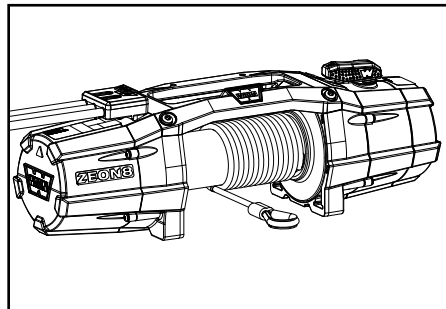
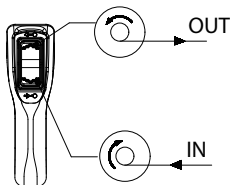

Figure 12



8. Installation complete.

INSTALLATION INSTRUCTION

Mounting Hole Drill Template

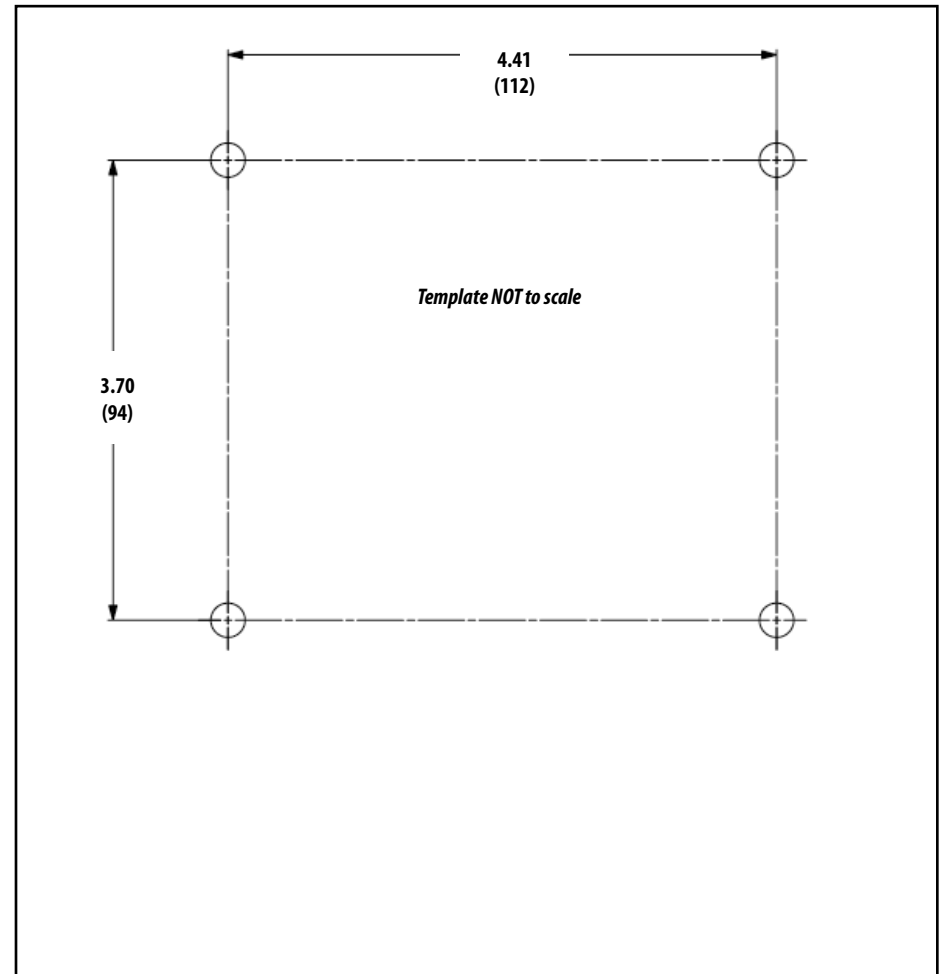

Template NOT to scale

