



SIGNATURE OF QUALITY

AUTOMOTIVE PRODUCTS, INC.

INSTALLATION INSTRUCTIONS

APPLICATION: GRILLE GUARD
2002-2004 NISSAN XTERRA
APP PART # 40-1435

ITEM	QUANTITY	DESCRIPTION	TOOLS NEEDED
1	1	GRILLE GUARD	RATCHET WRENCH
2	2	MOUNTING BRACKETS	PHILIPS SCREW-DRIVER
3	1	DRIVER/LEFT TOP BRACKET	
4	1	PASSENGER/RIGHT TOP BRACKET	
5	4	12-1.75MM X 35MM HEX BOLTS	
6	8	12MM ID X 37MM OD X 3MM FLAT WASHERS	
7	4	12 MM NYLON LOCK NUTS	
8	2	6-1.00MM X 25MM SOCKET HEAD CAP SCREWS	
9	2	6-1.00MM X 25MM PHILIPS HEAD SCREWS	
10	8	6MM ID X 18MM OD X 1.6MM FLAT WASHERS	
11	4	6MM NYLON LOCK NUTS	

ANTI-SEIZE LUBRICANT MUST BE USED ON ALL STAINLESS STEEL FASTENERS TO PREVENT THREAD DAMAGE AND GALLING

1. REMOVE CONTENTS FROM BOX. VERIFY ALL PARTS ARE PRESENT. READ INSTRUCTIONS CAREFULLY BEFORE STARTING INSTALLATION. **ASSISTANCE IS HIGHLY RECOMMENDED. CUTTING IS REQUIRED.**
 2. Start the installation from under the front of the vehicle and remove the plastic center panel on the lower bumper cover. From behind the passenger side of the plastic bumper cover, remove the (2) factory hex bolts securing the upper bumper bracket to the outside of the frame channel. Select (1) Mounting Bracket (Item 2) and bolt it to the bumper bracket and frame channel using the (2) factory hex bolts, **(Figure 1)**. Repeat this Step for driver side Mounting Bracket (Item 2) installation. Make sure that the plastic bumper cover is aligned properly and tighten hardware at this time. **NOTE:** It may be necessary to loosen-adjust the Mounting Bracket location later in the installation to align the Grille Guard, (Step 7).
 3. Hold the previously removed plastic center panel up in the original location. Mark the plastic cover and carefully cut for clearance around the Mounting Brackets, **(Figure 2)**. Reinstall the plastic cover using the factory hardware.
 4. Select the passenger side Top Mounting Bracket (Item 4). Remove the factory clip in the top of the grille opening securing the bumper cover to the inner bracket, **(Figure 3)**. Bolt the Top Bracket to the top hole in the plastic cover. Use the included (1) 6mm x 25mm Philips Head Screw (Item 9), (2) 6mm Flat Washers (Item 10) and (1) 6mm Nylon Lock Nut (Item 11) to attach the Top Bracket to the mounting location for the cover, **(Figure 3)**. Repeat this step to install the driver side Top Bracket. Snug hardware but do not tighten at this time.
 5. With assistance, position the Grille Guard (Item 1) up to the outside of the Mounting Brackets. Use the included (4) 12mm x 35mm Hex Bolts (Item 5) , (8) 12mm Flat Washers (Item 6) and (4) 12mm Nylon Lock Nuts (Item 7) to attach the Grille Guard to the Mounting Brackets, **(Figure 4)**. Do not tighten at this time.
 6. Push the Grille Guard into position and attach it to the Top Brackets using (2) 6mm x 25mm Socket Head Cap Screws (Item 8), (4) 6mm Flat Washers (Item 10) and (2) 6mm Nylon Lock Nuts (Item 11), **(Figure 3)**.
 7. Level and adjust the Grille Guard properly and tighten all hardware.
- Do periodic inspections to the installation to make sure that all hardware is secure and tight.



Westin Automotive Products, Inc.
320 Covina Blvd
San Dimas, Ca. 91773

Thank You for choosing Westin products
For Additional installation assistance please call
Customer service (800) 793-7846

www.westinautomotive.com

Passenger Side Installation Pictured

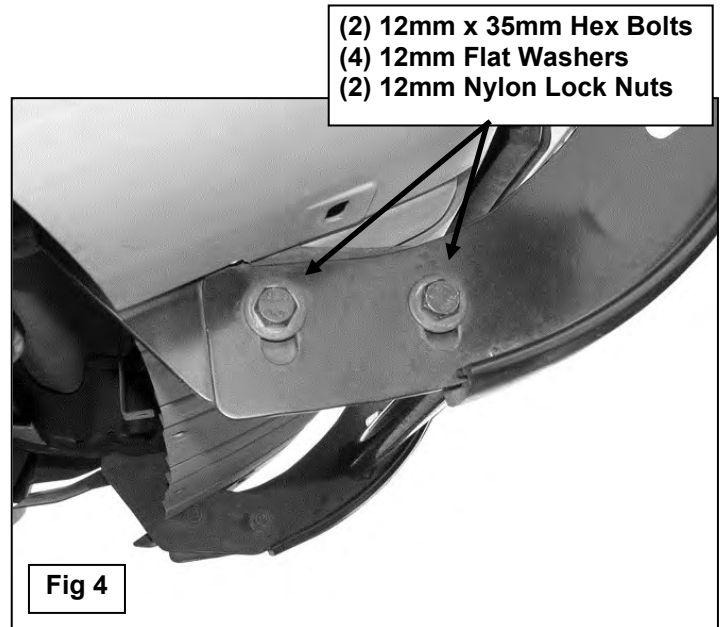
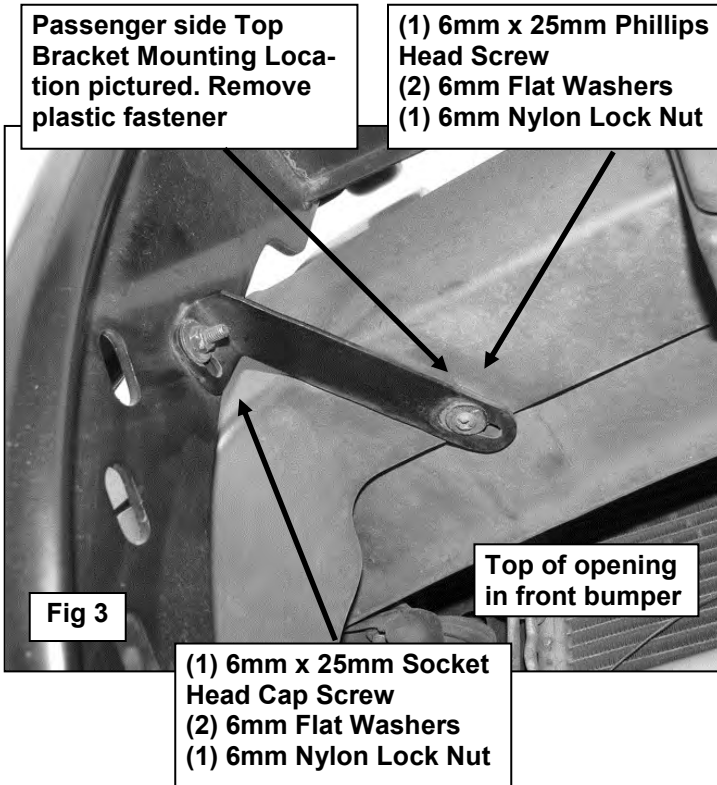
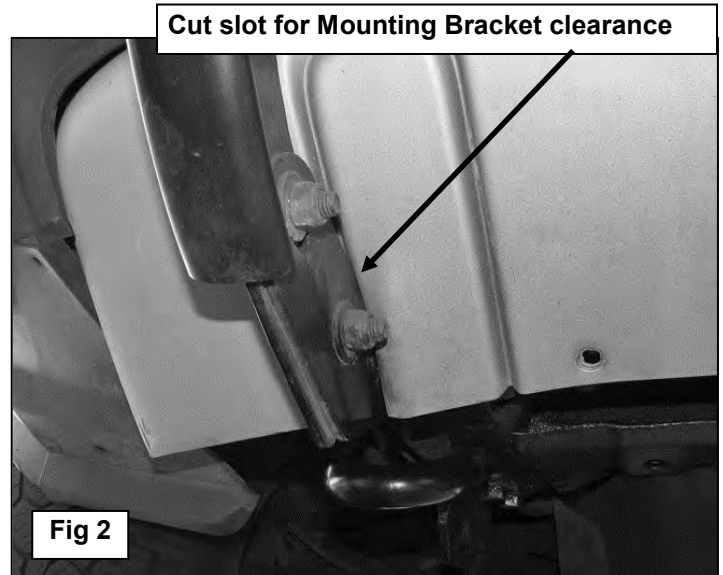
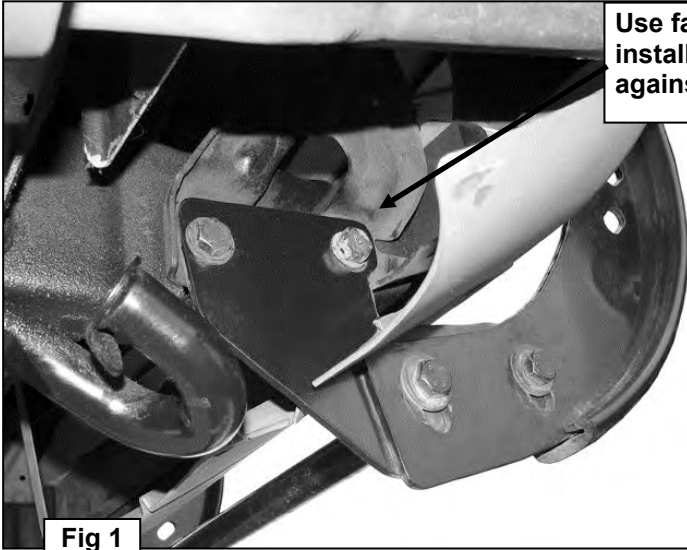

CARE INSTRUCTIONS

- REGULAR WAXING IS RECOMMENDED. DO NOT USE ANY TYPE OF POLISH OR WAX THAT MAY CONTAIN ABRASIVES
- STAINLESS STEEL PRODUCTS CAN BE CLEANED WITH MILD SOAP AND WATER. STAINLESS STEEL POLISH SHOULD BE USED TO POLISH SMALL SCRATCHES.
- GLOSS BLACK FINISHES SHOULD BE CLEANED WITH MILD SOAP AND WATER



Westin Automotive Products, Inc.
320 Covina Blvd
San Dimas, Ca. 91773

Thank You for choosing Westin products
For Additional installation assistance please call
Customer service (800) 793-7846
www.westinautomotive.com