



INSTALLATION INSTRUCTIONS

APPLICATION: REAR BUMPER
'97-02 FORD EXPEDITION

BUMPER KIT

30005
31004
33004

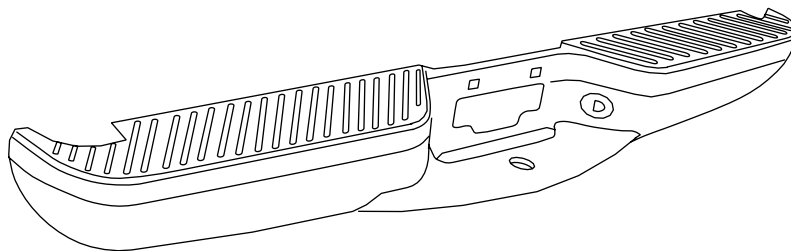

PERFECT MATCH BUMPER

QTY	PART KIT CONTENTS DESCRIPTION	TOOLS REQUIRED	QTY	BUMPER KIT CONTENTS DESCRIPTION
4	1/2-13 X 1 1/2" HEX HEAD BOLT	3/4" OPEN END WRENCH	1	BUMPER
4	1/2-13 HEX NUT	3/4" SOCKET	1	LIGHT KIT
8	1/2" FLAT WASHER	RATCHET		
4	1/2" SPLIT LOCK WASHER	TORQUE WRENCH		
		WIRE CRIMPING TOOL		

- STEP 1.** Remove contents from the box and check for any damage. Verify all parts against parts list. Read and understand instructions completely before beginning installation.
- STEP 2.** Position bumper to the frame of the vehicle so that the mounting holes on the bumper's hitch align with the mounting holes on the frame of the vehicle. Pass (1) 1/2-13 x 1 1/2" bolt along with (2) 1/2" flat washers and (1) 1/2" split lock washer through each hitch hole and into the vehicle's frame (See Figure 1).
- STEP 3.** Hand tighten (1) 1/2-13 nut onto each bolt. Use a 3/4" open end wrench to prevent each bolt from rotating while tightening each nut.
- STEP 4.** Position the bumper squarely to the rear of the vehicle. Allow enough clearance for the hatchback to open. Once the bumper has been positioned properly, tighten and torque each 1/2" hex nut to 65-70 ft-lbs. (90-95 N·m).
- STEP 5.** Use square plastic grommets and screws to install license plate (See Figure 2).
- STEP 6.** Install license plate lights into bumper. Splice light wires into truck wiring using supplied connectors. Ensure license plate lights are functioning properly. (See Figure 3).

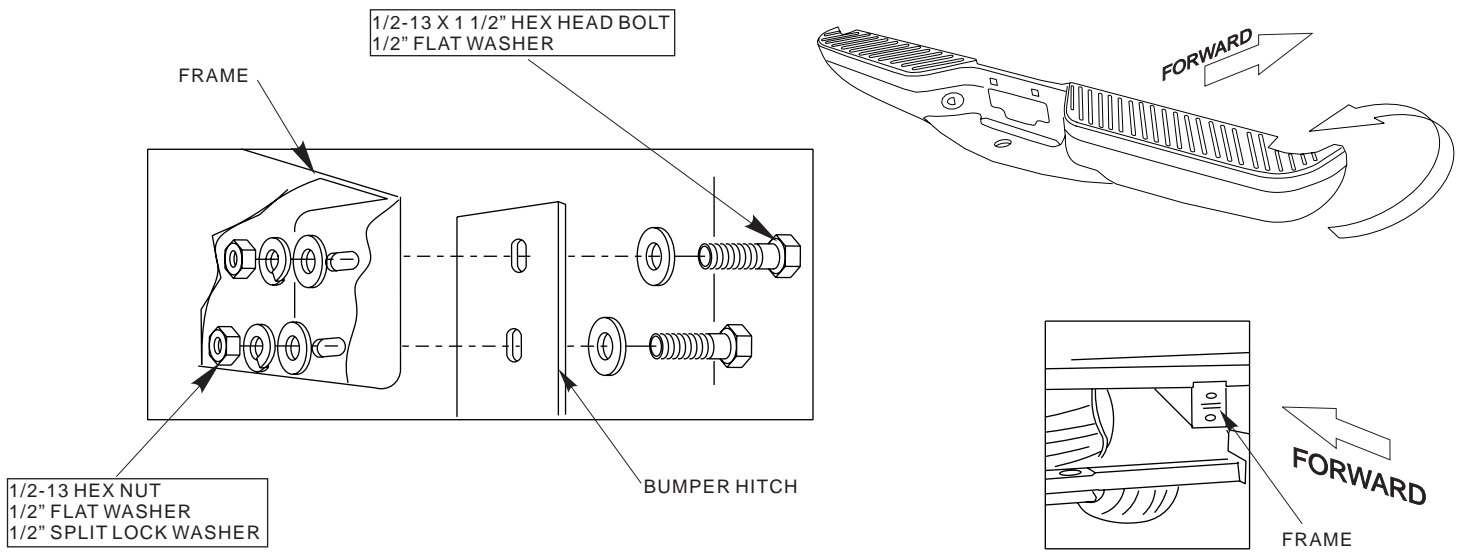

**FIGURE 1
(PASSENGER SIDE SHOWN, DRIVER SIDE OPPOSITE)**

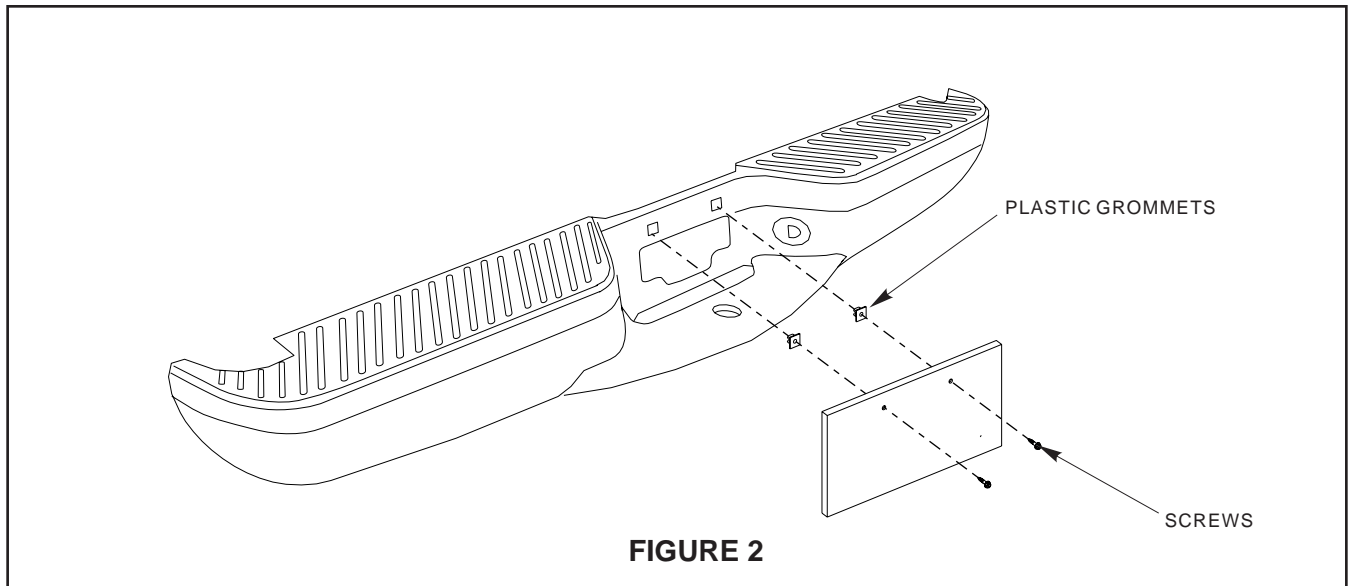

FIGURE 2

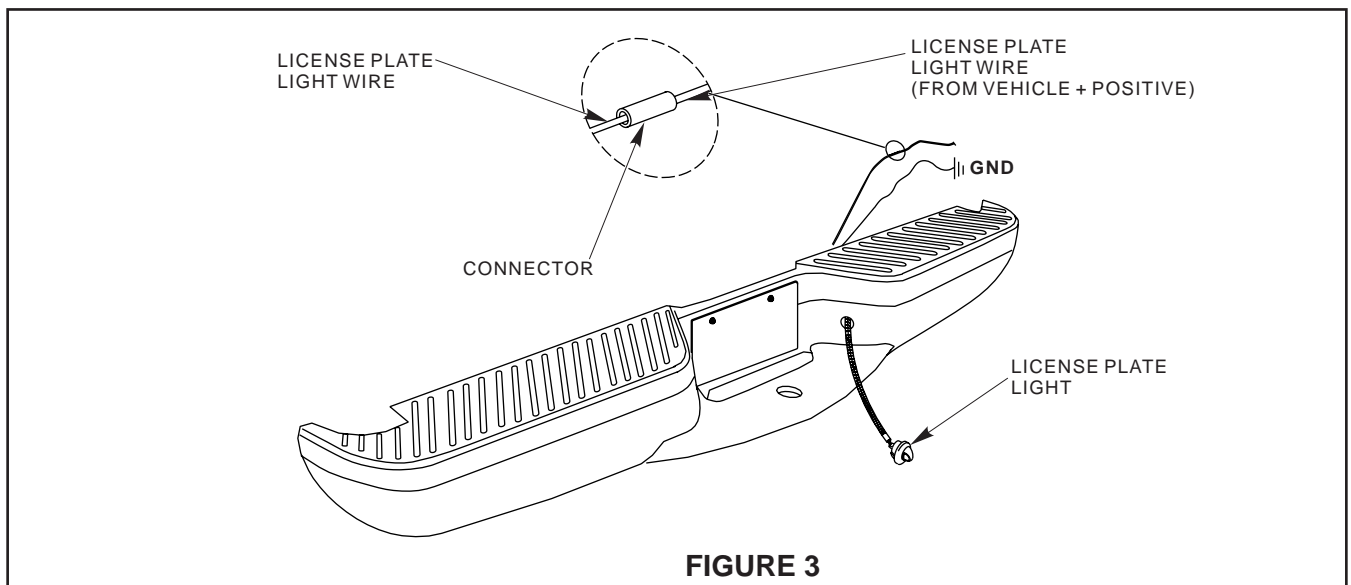

FIGURE 3