



INSTRUCTIONS—INSTRUCCIONES—CONSIGNES

APPLICATION: 08-ON NISSAN ROGUE

APP. PART # 23-3650, 23-3655

3" ROUND STEP BARS

AUTOMOTIVE PRODUCTS, INC.

ITEM	QUANTITY	DESCRIPTION	TOOLS NEEDED
1	2	STEP BARS	18 MM SOCKET
2,3	2	FRONT MOUNTING BRACKET (2) DRIVERS SIDE, (3) PASSENGER SIDE	16MM SOCKET
4,5	2	REAR MOUNTING BRACKET (4) DRIVERS SIDE, (5) PASSENGER SIDE	13MM SOCKET
6,7	2	FRONT SUPPORT BRACKET (6) DRIVERS SIDE, (7) PASSENGER SIDE	ALLEN KEY (INCLUDED)
8	2	LOCKING BRACKETS	RATCHET
9	2	M10 BOLT PLATES	TORQUE WRENCH
10	2	M12 BOLT/ M10 NUT PLATES	
11	10	M8 HEX HEAD BOLTS	
12	2	M8 BUTTON HEAD BOLTS	
13	12	M8 LOCK WASHERS	
14	2	M8 HEX NUTS	
15	12	M8 FLAT WASHERS	
16	4	M10 HEX HEAD BOLTS	
17	6	M10 LOCK WASHERS	
18	4	M10 HEX NUTS	
19	8	M10 FLAT WASHERS	
20	2	M12 LOCK WASHERS	
21	2	M12 HEX NUTS	
22	2	M12 FENDER WASHERS	

1. Remove contents from box, verify all parts listed are present and free from damage. Carefully read and understand all I instructions before attempting installation.
2. Remove the front rubber plug in the bottom of the vehicle's body (Figure 1). Insert (1) M10 Bolt Plate with the metal plate facing the front of the vehicle, once inserted turn Bolt Plate around so the longer Metal Plate is facing the rear of the vehicle, and then push Bolt Plate towards the front of the vehicle to fully engage (Figure 2).
3. Position driver side Locking Bracket over already inserted Bolt Plate then push Locking Bracket all the way to the front of the vehicle and secure it using the included (1) M10 Flat Washer, (1) M10 Lock Washer, and (1) M10 Hex Nut (Figure 3).
4. Once the Locking Bracket is all the way to the front of the vehicle, use a pair of vice grips to hold Locking Bracket in place when drilling (Figure 4). NOTE: Use a cloth to protect the finish of the Locking Bracket.
5. Use the hole in the Locking Bracket as a template to drill a 5/16" hole in the pinch weld (Figure 5).
6. Secure the Locking Bracket to pinch weld using the included (1) M8 Button Head Bolt, (1) M8 Locking Washer, (1) M8 Flat Washer, and (1) M8 Hex Nut. Fully tighten at this time.
7. Loosely attach driver side Support Bracket over Locking Bracket and to already inserted Bolt Plate using the included (1) M10 Lock Washer, (1) M10 Flat Washer, and (1) M10 Hex Nut (Figure 6).
8. Locate the two factory bolts in the front of frame rail, and then remove the one towards the rear of the vehicle (Figure 7).



Westing Automotive Products, Inc.
5200 N. Irwindale Ave. Suite 220
Irwindale, Ca. 91706

3/29/2011 P.N.: 75-0044-RevA

Thank You for choosing Westin products
For Additional installation assistance please call
Customer service (800) 793-7846
www.westinautomotive.com

9. Partially attach the driver side front Mounting Bracket to the existing rear factory bolt location using the included (1) M8 Hex Head Bolt (this replaces the factory bolt removed in step eight), (1) M8 Lock Washer, and (1) M8 Washer (Figure 8).
10. Attach the driver side front Mounting Bracket to Support Bracket using the included (1) M10 Hex Head Bolt, (1) M10 Lock Washer, (1) M10 Hex Nut, and (2) M10 Flat Washers. Do not tighten at this time (Figure 9).
11. There are three factory holes in the rear floor panel, one oval and two round. Insert (1) Bolt Plate with Nut through slotted factory hole and orient it so Nut lines up with larger round hole (Figure 10).
12. Partially attach driver side rear Mounting Bracket to already inserted Bolt Plate using the included (1) M12 Lock Washer, (1) M12 Fender Washer, (1) M12 Hex Nut and attach Bracket to Nut using the included (1) M10 Hex Head Bolt, (1) M10 Lock Washer, and (1) M10 Flat Washer (Figure 11).
13. Position driver Sidebar onto Mounting Brackets and attach it using the included (4) M8 Hex Head Bolts, (4) M8 Lock Washers, and (4) M8 Flat Washers (Figure 12). Do not tighten at this time.
14. Adjust Sidebar properly, and then tighten all hardware at this time.
15. Repeat steps 2-14 for passenger side

CARE INSTRUCTIONS

- REGULAR WAXING IS RECOMMENDED. DO NOT USE ANY TYPE OF POLISH OR WAX THAT MAY CONTAIN ABRASIVES
- STAINLESS STEEL PRODUCTS CAN BE CLEANED WITH MILD SOAP AND WATER. STAINLESS STEEL POLISH SHOULD BE USED TO POLISH SMALL SCRATCHES.

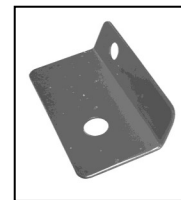
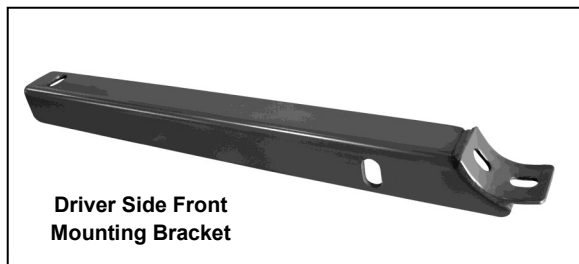
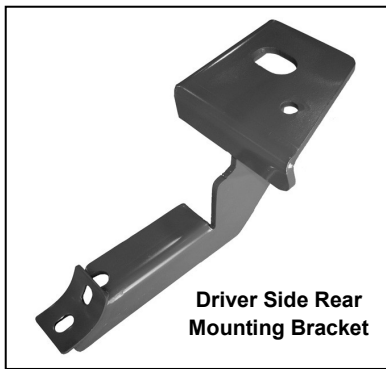

Westin Automotive Products, Inc.
5200 N. Irwindale Ave. Suite 220
Irwindale, Ca. 91706

Thank You for choosing Westin products
For Additional installation assistance please call
Customer service (800) 793-7846
www.westinautomotive.com

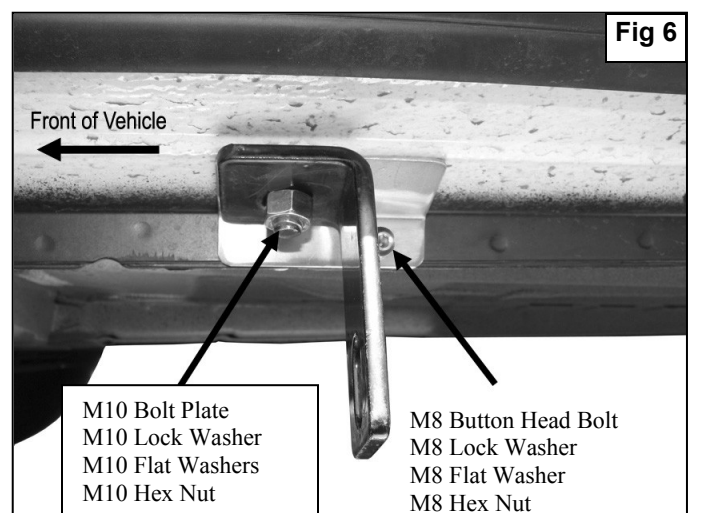
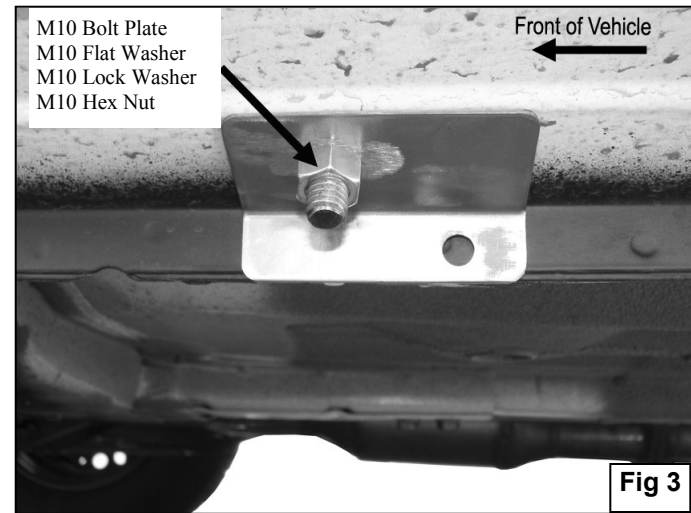
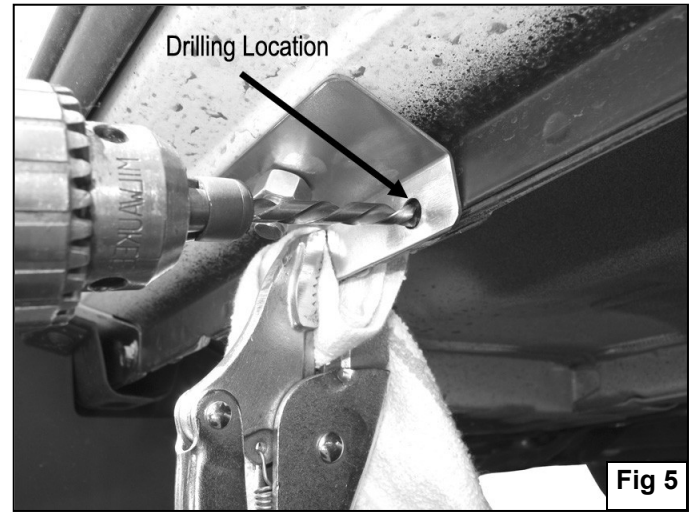
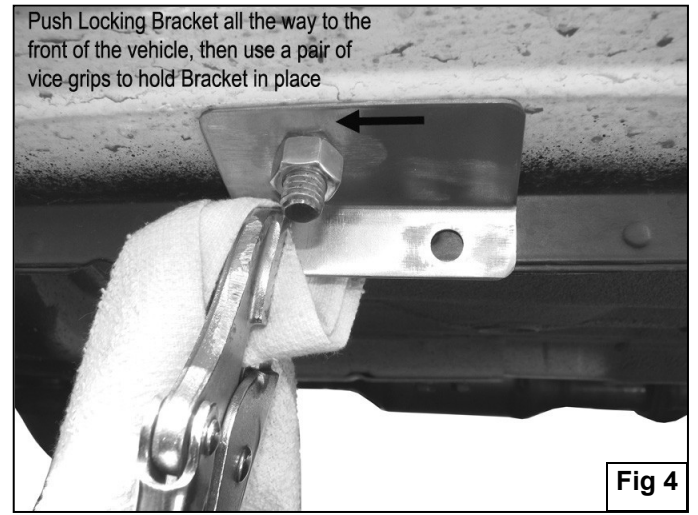
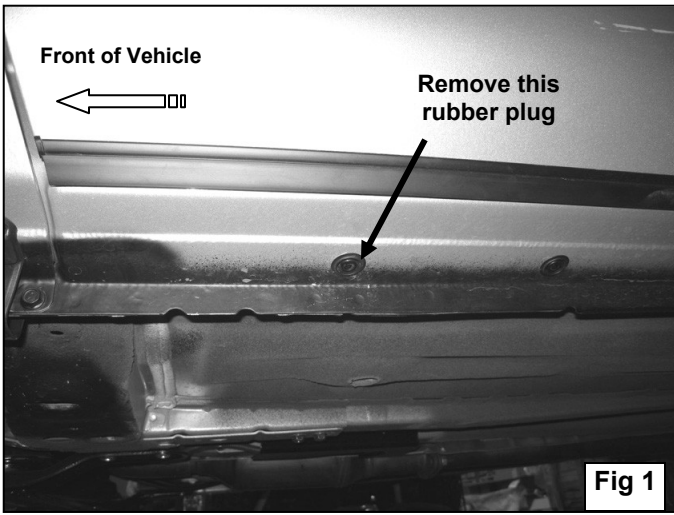

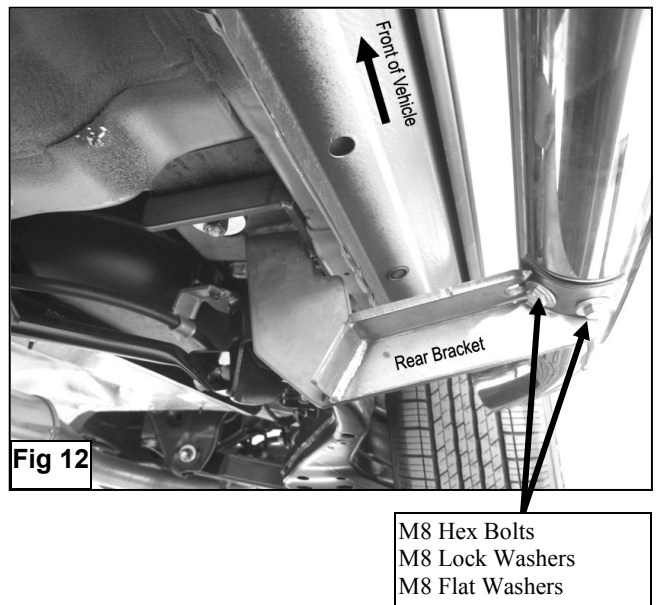
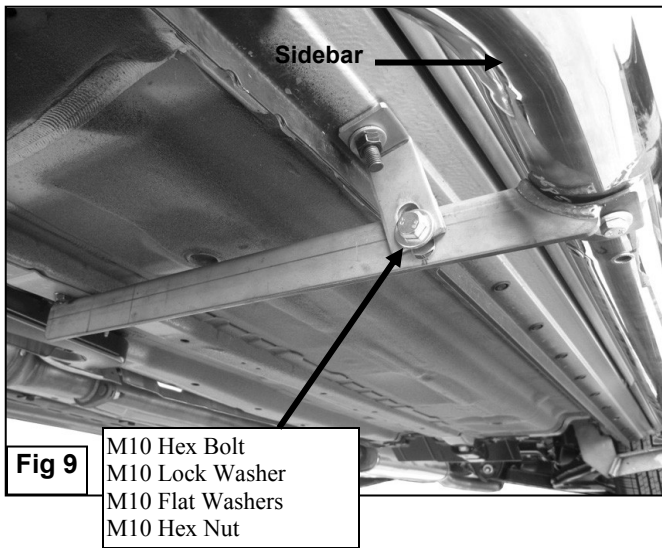
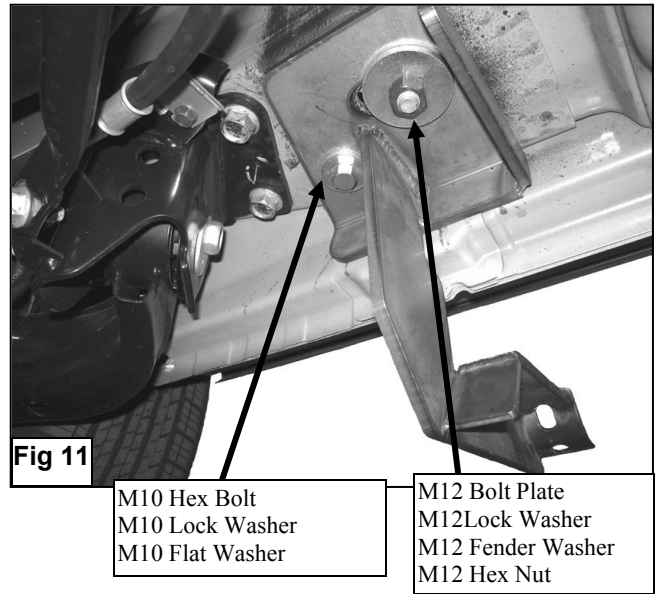
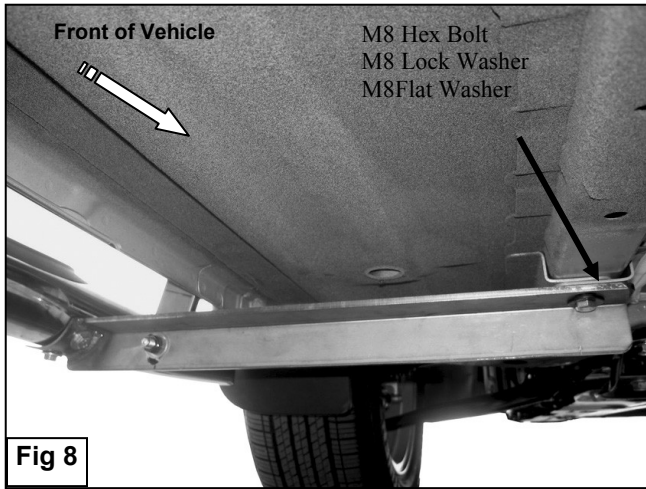
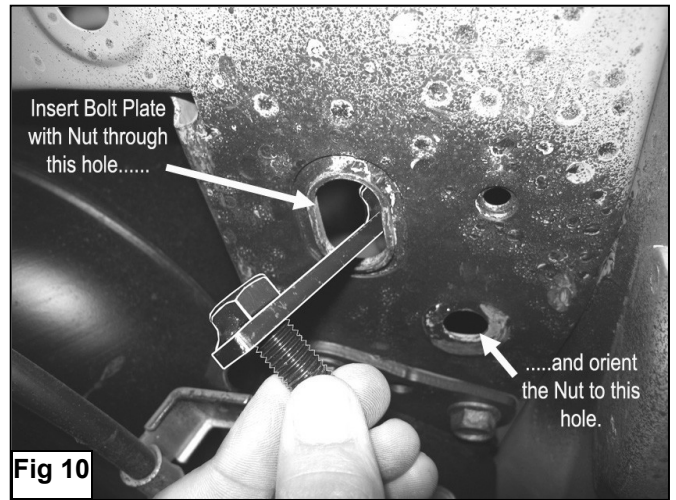
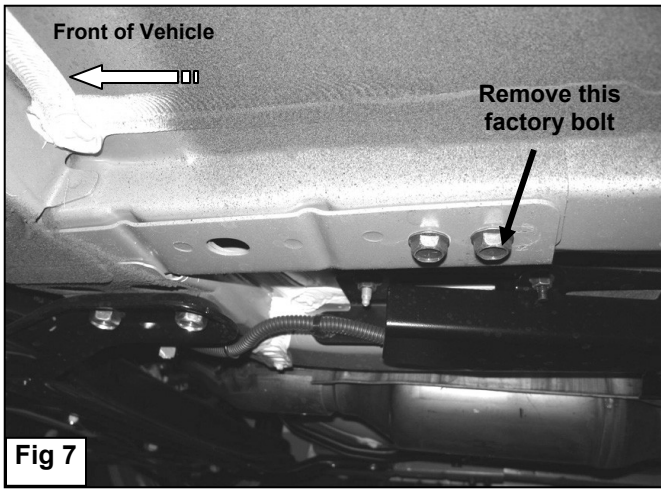

Westing Automotive Products, Inc.
5200 N. Irwindale Ave. Suite 220
Irwindale, Ca. 91706

3/29/2011 P.N.: 75-0044-RevA

Thank You for choosing Westin products
For Additional installation assistance please call
Customer service (800) 793-7846
www.westingautomotive.com