



AUTOMOTIVE PRODUCTS, INC.

INSTRUCTIONS—INSTRUCCIONES—CONSIGNES

APPLICATION: 02-06 GMC ENVOY/ 04-06 CHEVY TRAILBLAZER/ 03-06 ISUZU ASCENDER
APP.PART # 23-2240, 23-2245
3" ROUND STEP BARS

ITEM	QUANTITY	DESCRIPTION	TOOLS NEEDED
1	2	STEP BARS	13MM SOCKET
2,3	2	FRONT MOUNTING BRACKETS (2) DRIVERS SIDE, (3) PASSENGER SIDE	RATCHET
4,5	2	REAR MOUNTING BRACKETS (4) DRIVERS SIDE, (5) PASSENGER SIDE	TORQUE WRENCH
6	4	"L" SUPPORT BRACKETS	
7	4	M8 HEX NUTS	
8	20	M8 LARGE FLAT WASHERS	
9	16	M8 X 30MM HEX HEAD BOLTS	
10	24	M8 LOCK WASHERS	
11	8	M8 x 25MM HEX HEAD BOLTS	
12	8	M8 FLAT WASHERS	

1. Remove all contents from box, verify if all parts listed are present and free from damage. Carefully read and understand all instructions before attempting installation.
2. Start installation on the passenger side front of the vehicle. Locate the (2) factory threaded holes in the side of the body panel and the (2) lower threaded holes near the pinch weld, (Figure 1). Select (1) passenger side Mounting Bracket. Bolt the Bracket to the (2) upper threaded holes with (2) M8 x 30mm Hex Bolts, (2) M8 Lock Washers and (2) M8 Large Flat Washers, (Figure 2). Do not tighten hardware at this time.
3. Next, select (1) "L" shaped Support Bracket. Bolt the short end of the Support Bracket to the forward threaded hole near the pinch weld with (1) M8 x 30mm Hex Bolt, (1) M8 Lock Washer and (1) M8 Large Flat Washer, (Figure 3). Line up the remaining hole in the Support Bracket with the slot in the Mounting Bracket. Bolt the Support Bracket to the Mounting Bracket with (1) M8 Hex Bolt, (1) M8 Lock Washer, (2) M8 Large Flat Washers and (1) M8 Hex Nut. Do not tighten hardware at this time.
4. Repeat Steps 2 – 3 for the passenger side rear Mounting Bracket installation.
5. Carefully position the passenger Sidebar onto the Mounting Brackets. Bolt the Sidebar to the Mounting Brackets with the included (4) M8 Hex Bolts, (4) M8 Lock Washers and (4) M8 Flat Washers, (Figure 4).
6. Level and adjust the Sidebar properly and tighten all hardware at this time.
7. Repeat Steps 2 – 6 for driver Sidebar installation.

CARE INSTRUCTIONS

- REGULAR WAXING IS RECOMMENDED. DO NOT USE ANY TYPE OF POLISH OR WAX THAT MAY CONTAIN ABRASIVES
- STAINLESS STEEL PRODUCTS CAN BE CLEANED WITH MILD SOAP AND WATER. STAINLESS STEEL POLISH SHOULD BE USED TO POLISH SMALL SCRATCHES.
- GLOSS BLACK FINISHES SHOULD BE CLEANED WITH MILD SOAP AND WATER



Westin Automotive Products, Inc.
5200 N. Irwindale Ave. Suite 220
Irwindale, Ca. 91706

11/3/2011 P.N.: 75-0049-Rev B W11-0109

PG-1

Thank You for choosing Westin products
For Additional installation assistance please call
Customer service (800) 793-7846
www.westinautomotive.com

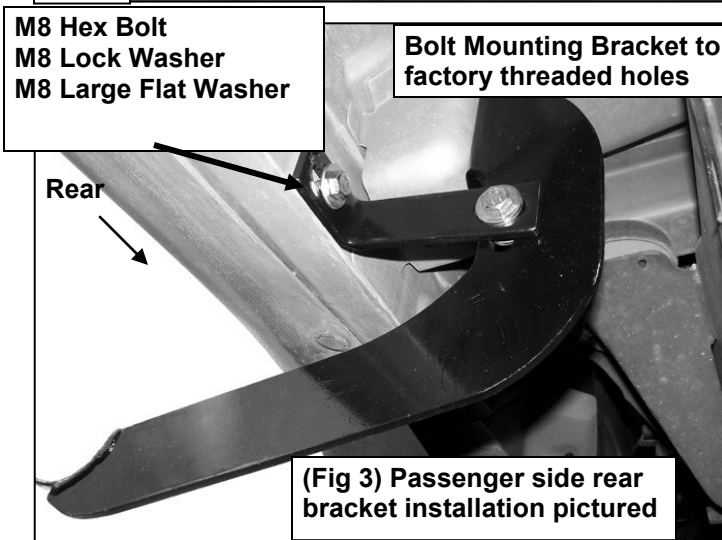
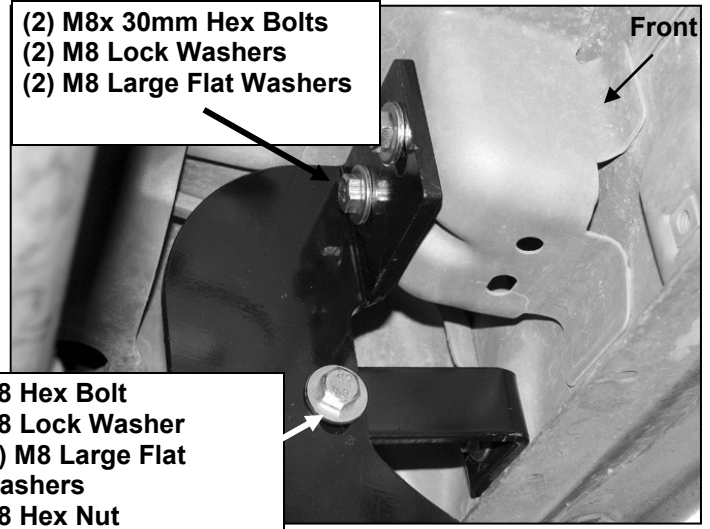
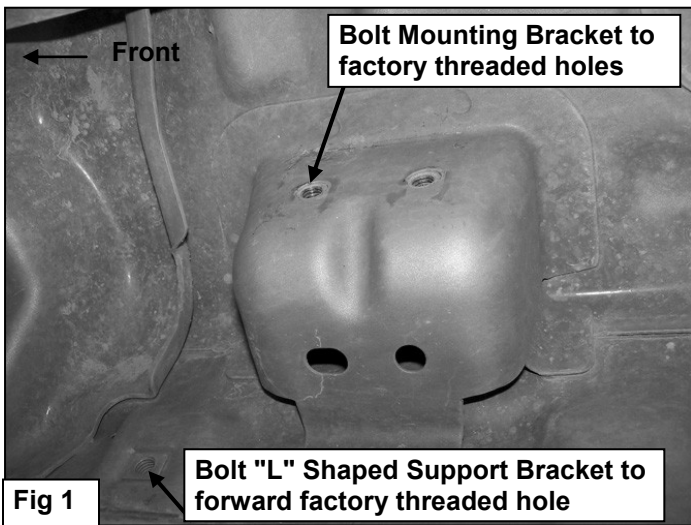
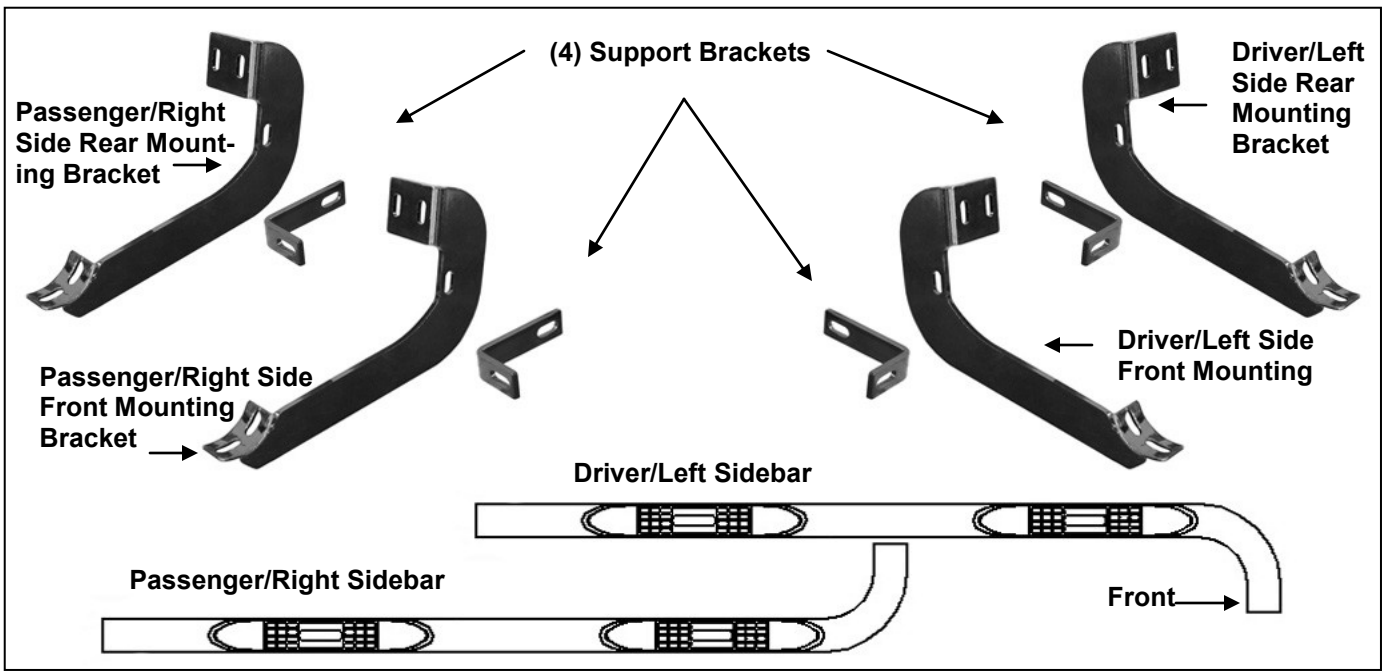

Westing Automotive Products, Inc.
5200 N. Irwindale Ave. Suite 220
Irwindale, Ca. 91706

Thank You for choosing Westin products
For Additional installation assistance please call
Customer service (800) 793-7846
www.westinautomotive.com



Westing Automotive Products, Inc.
5200 N. Irwindale Ave. Suite 220
Irwindale, Ca. 91706

11/3/2011 P.N.: 75-0049-Rev B W11-0109

PG-3

Thank You for choosing Westin products
For Additional installation assistance please call
Customer service (800) 793-7846
www.westinautomotive.com