



SIGNATURE OF QUALITY

INSTRUCTIONS—INSTRUCCIONES—CONSIGNES

APPLICATION: 2003-15 1500/2500/3500 HD SILVERADO/SIERRA EXTENDED CAB/DOUBLE CAB/CREW CAB
INCLUDING DIESEL EQUIPPED & 03-07 CLASSIC MODELS
PART # 57-51685, 57-51955 HDX RUNNING BOARDS

AUTOMOTIVE PRODUCTS, INC.

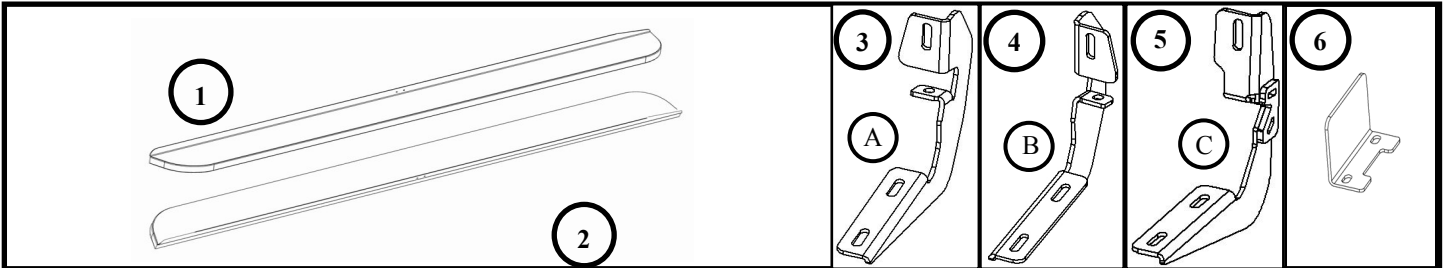

ITEM	QUANTITY	DESCRIPTION	TOOLS NEEDED
1	1	RUNNING BOARD PASSENGER	13MM SOCKET
2	1	RUNNING BOARD DRIVER	10MM SOCKET
3	3	BRACKET ASSEMBLY, "A"	13MM WRENCH
4	4	BRACKET ASSEMBLY, "B"	RATCHET
5	1	BRACKET ASSEMBLY, "C"	RATCHET EXTENSION
6	2	BOOT SCRAPER	TORQUE WRENCH
7	32	M8-1.25X30 HEX HEAD CAP SCREW, CLASS 8.8	7/16" DRILL BIT
8	33	M8 FLAT WASHER, 24MM OD x 2MM THICK	3/16" DRILL BIT
9	32	M8 SPLIT LOCK WASHER	5/16" DRILL BIT
10	32	M8-1.25 EXTRUDED U-NUT	PLIERS
11	1	M8-1.25 HEX NUT, CLASS 8	FLAT HEAD SCREW DRIVER
12	8	M6 x 25mm HEX WASHER HEAD SELF DRILLING SCREW	
13	4	9.5 EXTERNAL TOOTH LOCK WASHER	
14	4	M9.5 x 25mm HEX WASHER HEAD SELF TAP SCREW	

ANTI-SEIZE LUBRICANT MUST BE USED ON ALL STAINLESS STEEL FASTENERS TO PREVENT THREAD DAMAGE AND GALLING .

1. Remove contents from box, verify if all parts listed are present and free from damage. Carefully read and understand all instructions before attempting installation.
2. Identify driver and passenger side running boards (Fig.1) and install M8 u-nut clips (Item 10) to the underside of the boards. (Fig. 1)
3. If you have a 03–07 classic model please proceed to step 10 page 4.
4. Locate on each of both rocker panel sides, the rubber plugs and remove the insert plugs. Install M8 u-nut clips (item 10) as shown on Fig.2, except where the "C" mounting bracket (item 5) is being used. (To reference each mounting brackets corresponding position refer to Fig.6 & 7 on pg.3). Take the mounting bracket and install the bracket (referencing hardware figure 3) to its corresponding positions. *Do not fully tighten at this time. Note: On 1500 Crew Cab models, front positions will have pre-existing threads.*
5. For 2011-2015 Diesel equipped Models the D.E.F tank must be removed to install the brackets on the passenger side. For D.E.F. tank removal please refer to page 5. **Note: Bracket location placement is critical.**
6. After all brackets have been installed loosely, take (1) Running Board (item 1 or 2) and place running board on top of the mounting brackets. (Fig. 5) Loosely install the M8 hardware, align adjust the board, then tighten all M8 hardware to 20 ft lbs. (Fig. 4 & 5)
7. Proceed to re-install D.E.F. tank on 11-15 diesel.



Westin Automotive Products, Inc.
320 Covina Blvd
San Dimas, Ca. 91773

Thank You for choosing Westin products
For Additional installation assistance please call
Customer service (800) 793-7846
www.westinautomotive.com

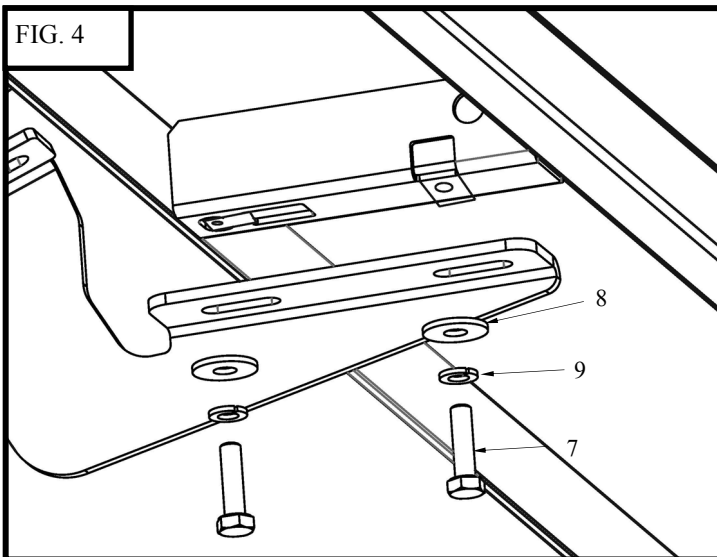
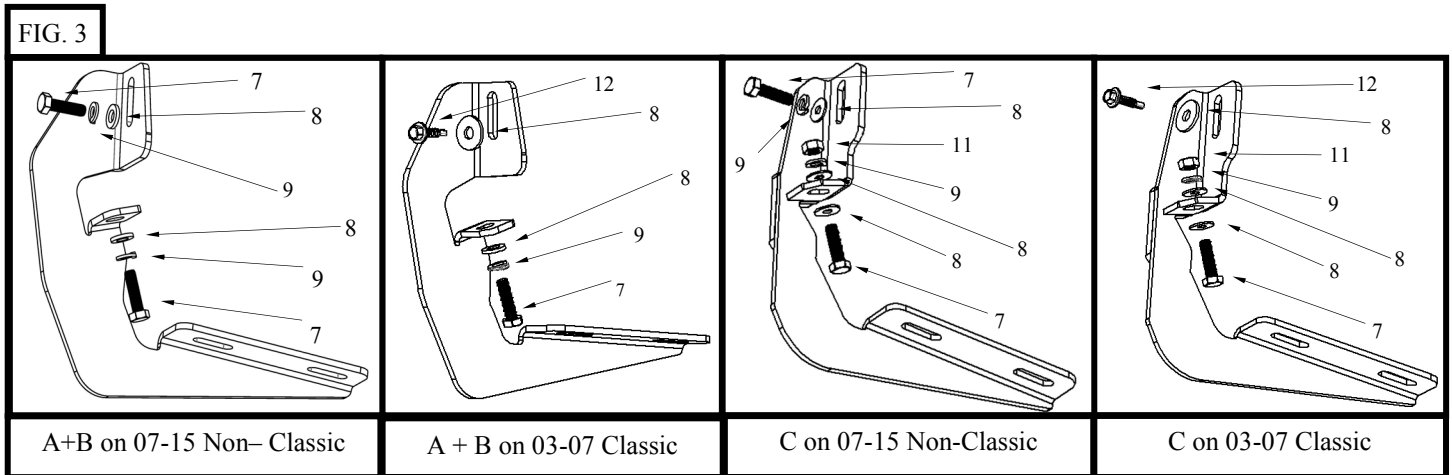
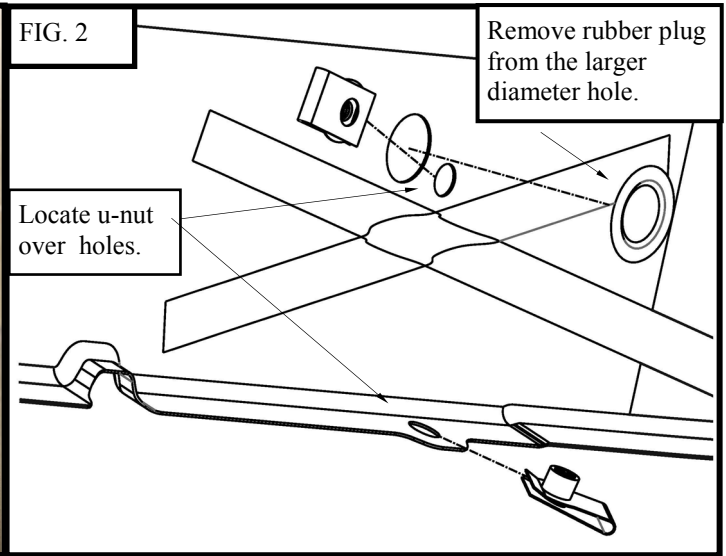
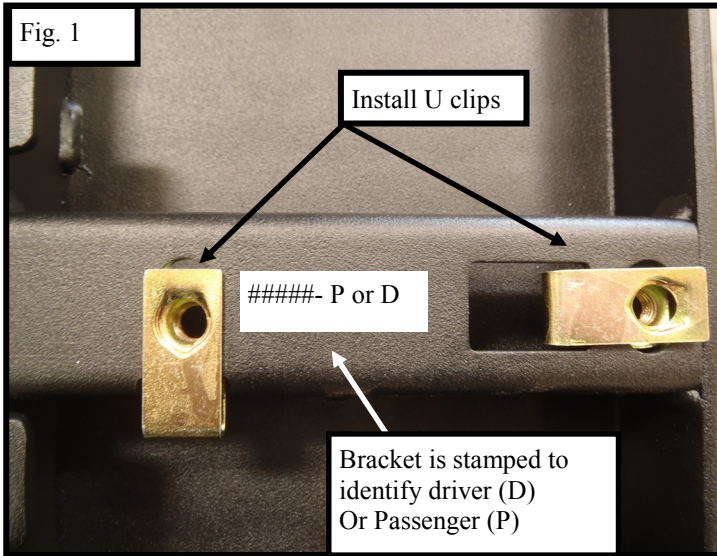
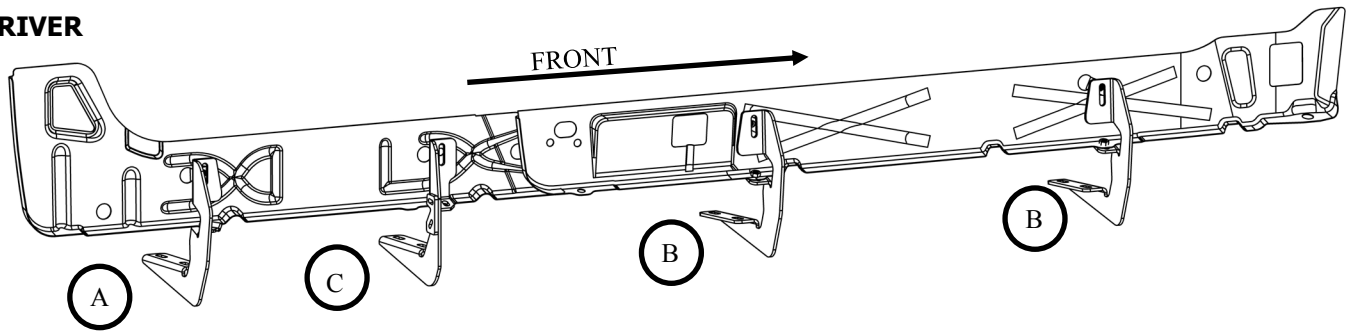

Fig. 6

ALL 03-10 DIESEL & 03-15 GAS SILVERADO/SIERRA: EXTENDED & DOUBLE CAB/CREW CAB

DRIVER



PASSENGER

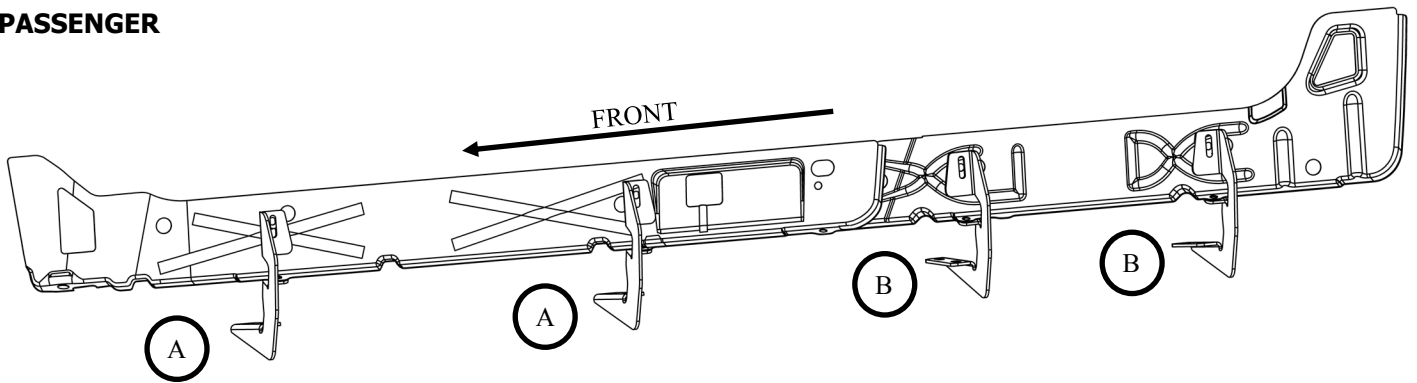
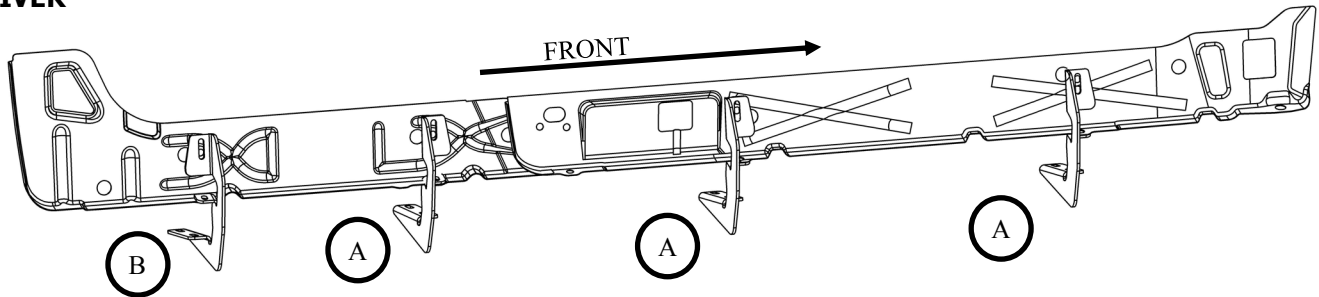

Fig. 7

ALL 11-15 DIESEL SILVERADO/SIERRA: EXTENDED & DOUBLE CAB/CREW CAB.

DRIVER



PASSENGER

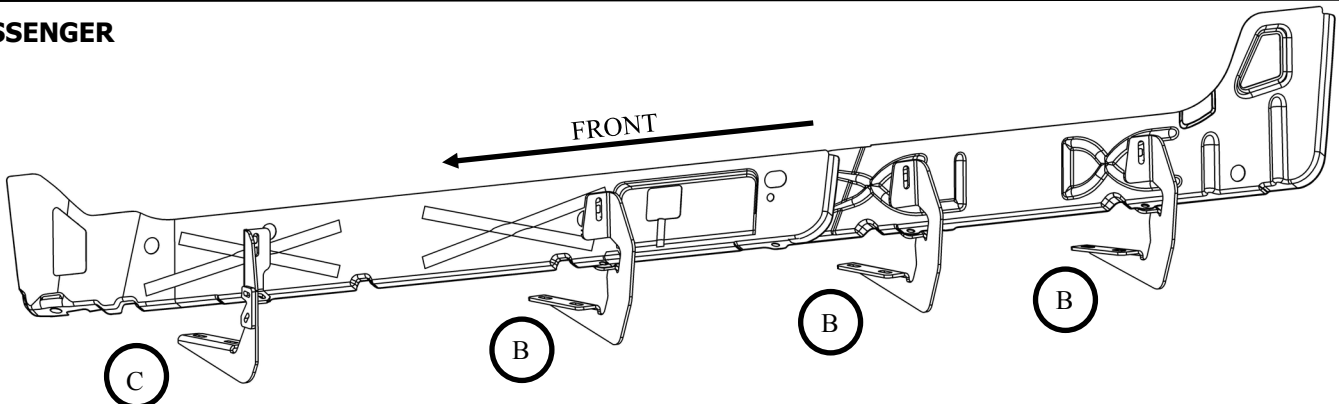

Westin Automotive Products, Inc.
320 Covina Blvd
San Dimas, Ca. 91773

Thank You for choosing Westin products
For Additional installation assistance please call
Customer service (800) 793-7846
www.westinautomotive.com

8. **03-07 CLASSIC MODELS:** Some of the rocker panels and pinch welds do not have pre-existing holes or threaded holes. For this reason the mounts must be installed first only on the front. To do so locate the threaded hole on the either passenger or driver side rocker panel. Attach the corresponding mounts to the two most forward locations (see figure 6 on page 3). Mount the brackets to the threaded holes (Fig.3). *Do not fully tighten at this time.*
9. Take either running board and following step 6 on page 1 and attach the running board to the two front mounts.
10. Attach the corresponding brackets, as shown on figure 6 on page 3, to the running board. Align the brackets with the pinch weld and rocker panel.
11. The pinch weld has tabs that protrude out. These tabs should align with the bottom of each mounting bracket. Using a transfer punch, punch a mark approximately 3/8" away from the edge of the tab (Fig.8) . Once the marks have been made, remove the running board and the rear brackets.
12. Take a 3/16" drill bit and align it with the previously made marks and drill a pilot hole. Use a 7/16" drill bit to open the pilot hole to 7/16".
13. Install M8 u-nuts (item 10) on the holes (Fig. 2) except where the "C" mounting bracket is (item 5) to be installed. *Do not fully tighten at this time.* (Fig. 2)
14. Re-install the running boards and rear brackets. Align and adjust the board, then tighten all M8 hardware to 20 ft lbs. (Fig. 5)
15. Take a 10mm socket, drill gun, (1) M6 hex head self drilling screw (item 12) and (1) M8 flat washer (item 8), and drill the screw through the hole on the top part of the mounting bracket to the rocker panel. (Fig. 3) Torque to 5 ft lbs.

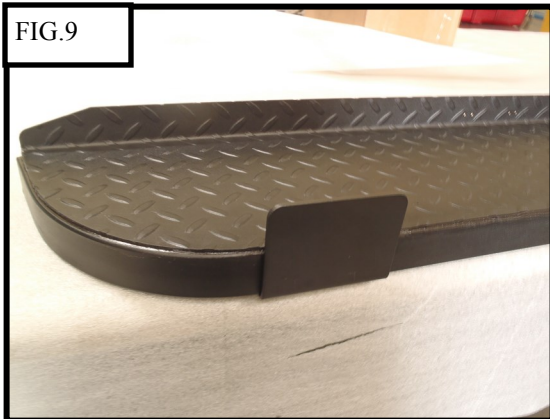
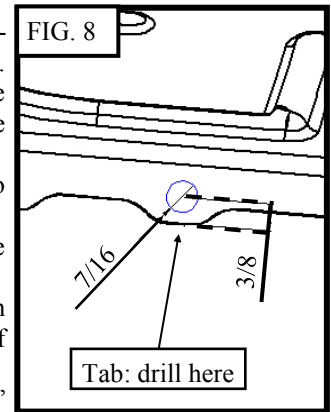

Boot scraper (OPTIONAL) can be installed anywhere on the underside front edge of the running board. Place the boot scraper (item 6) on the underside of the running board rail. Then mark the position that it will be installed using a transfer punch. Remove the boot scraper; then using a 5/16" drill bit align it with the previously made marks and drill through the bottom of the rail on the running board. Thread in (2x) 9.5mm hex head self tapping screws (item 14). Remove the screws and add some silicone sealant in the holes to prevent rust. Attach the boot scraper (item 6) using (2) 9.5mm hex self tapping screws (item 14) and (2) 9.5mm external toothed lock washers (item 13). (Fig. 9 & 10) Torque all M9.5 hardware to 18 ft lbs.

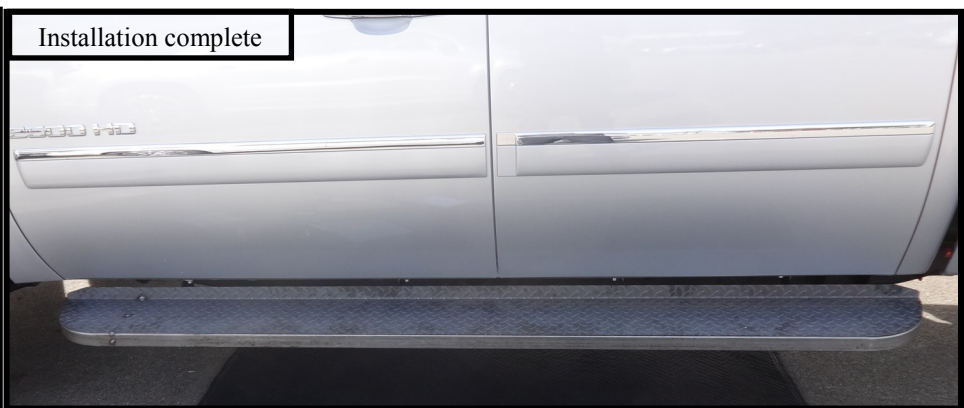
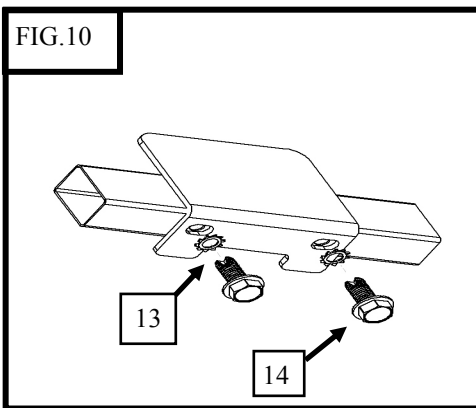

CARE INSTRUCTIONS

- REGULAR WAXING IS RECOMMENDED. DO NOT USE ANY TYPE OF POLISH OR WAX THAT MAY CONTAIN ABRASIVES
- STAINLESS STEEL PRODUCTS CAN BE CLEANED WITH MILD SOAP AND WATER. STAINLESS STEEL POLISH SHOULD BE USED TO POLISH SMALL SCRATCHES.
- GLOSS BLACK FINISHES SHOULD BE CLEANED WITH MILD SOAP AND WATER.

DEF TANK REMOVAL INSTRUCTIONS FOR 11-15 DIESEL MODELS ONLY

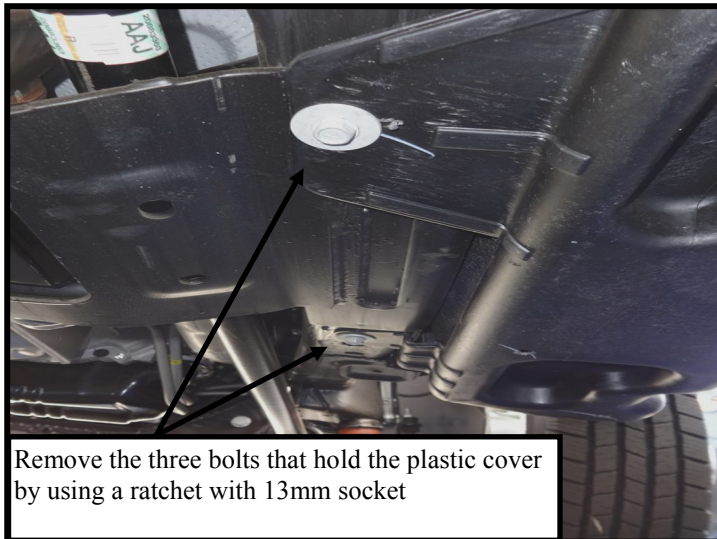

Remove the three bolts that hold the plastic cover by using a ratchet with 13mm socket

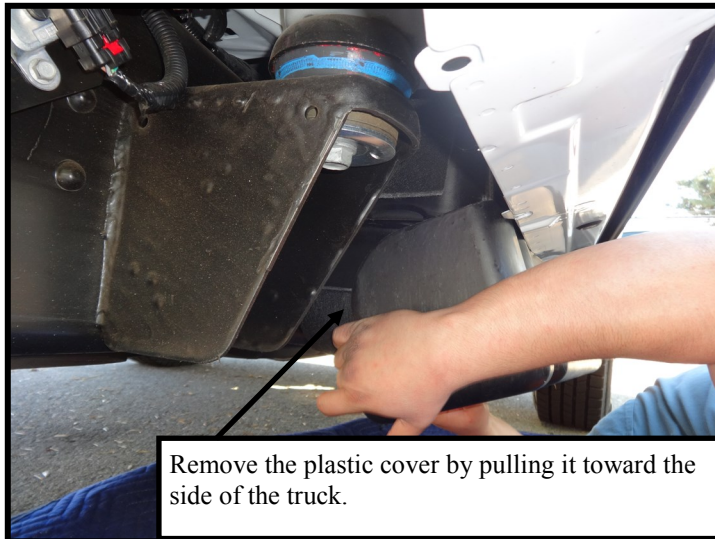

Remove the plastic cover by pulling it toward the side of the truck.

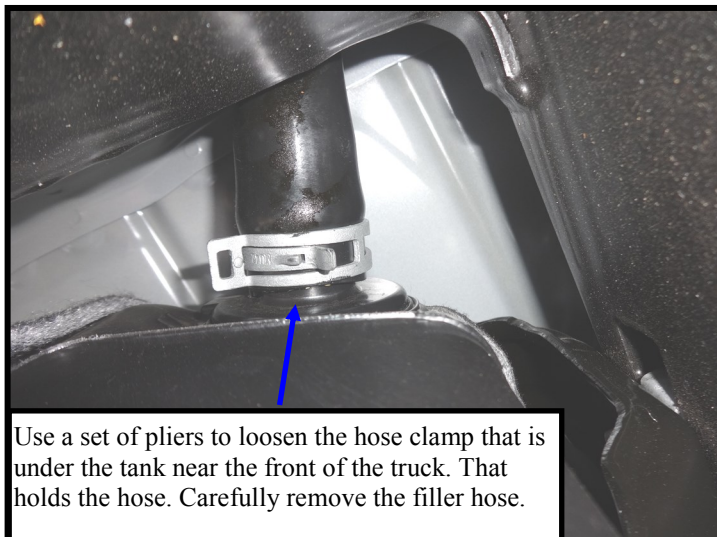

Use a set of pliers to loosen the hose clamp that is under the tank near the front of the truck. That holds the hose. Carefully remove the filler hose.

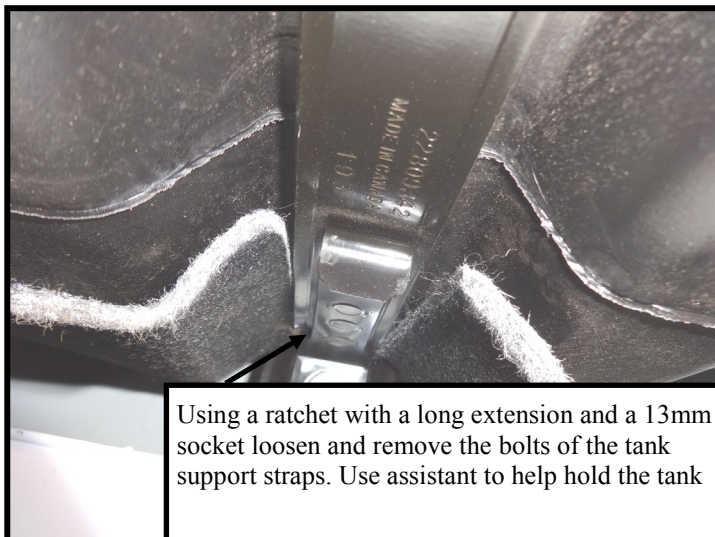

Using a ratchet with a long extension and a 13mm socket loosen and remove the bolts of the tank support straps. Use assistant to help hold the tank

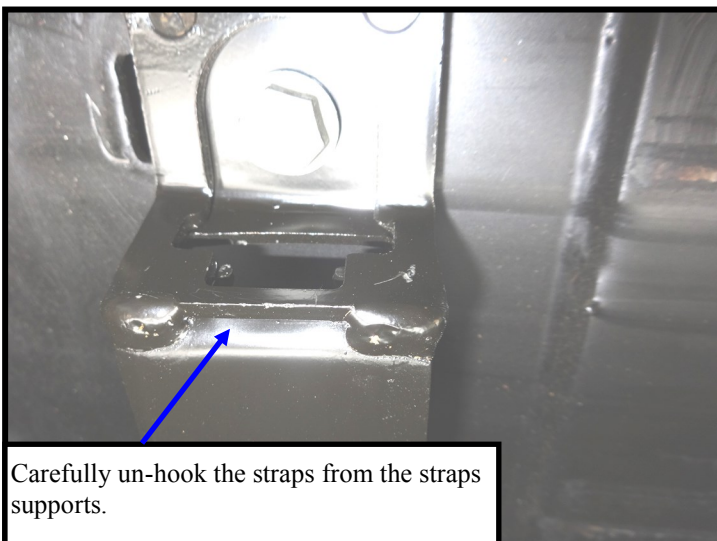

Carefully un-hook the straps from the straps supports.

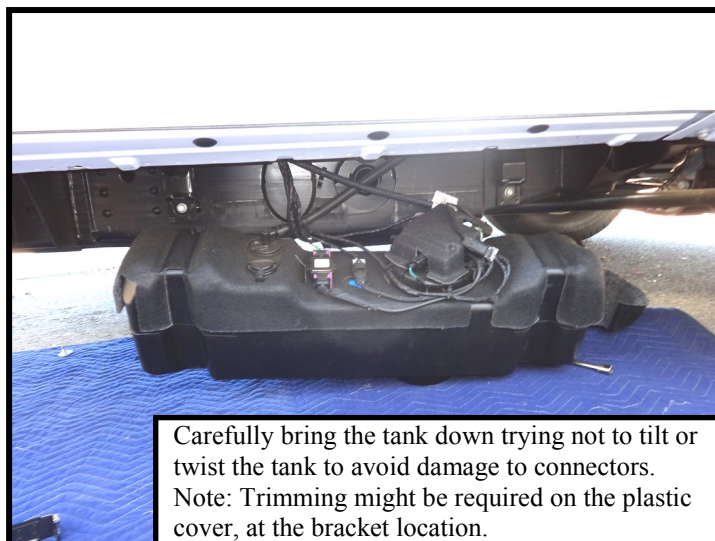

Carefully bring the tank down trying not to tilt or twist the tank to avoid damage to connectors. Note: Trimming might be required on the plastic cover, at the bracket location.



Westin Automotive Products, Inc.
320 Covina Blvd
San Dimas, Ca. 91773