

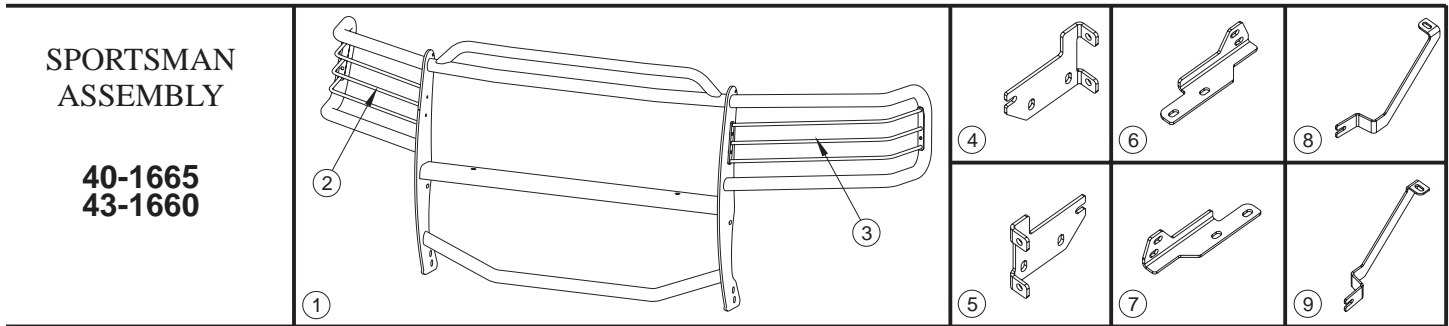

INSTALLATION INSTRUCTIONS

APPLICATION: 2005-UP DODGE DAKOTA 2/4 WHEEL DRIVE

AUTOMOTIVE PRODUCTS, INC.



PARTS KIT CONTENTS

ITEM	QTY	DESCRIPTION	ITEM	QTY	DESCRIPTION
1	1	SPORTSMAN ASSEMBLY	14	4	3/8-16 X 1.25" HEX HEAD BOLT
2,3	2	LIGHT GUARD ASSEMBLY, PASSENGER(2) & DRIVER(3)	15	2	3/8" FLAT WASHER
4,5	2	TOP BRACKET, PASSENGER(4) & DRIVER(5)	16	4	3/8" LOCK WASHER
6,7	2	BOTTOM BRACKET, PASSENGER(6) & DRIVER(7)	17	8	3/8-16 HEX NUT
8,9	2	SUPPORT BRACE, PASSENGER(8) & DRIVER(9)	18	4	3/8-16 X 1.25" BUTTON HEAD BOLT
10	8	1/2-13 X 1.25" HEX HEAD BOLT	19	4	RUBBER BUMPER
11	16	1/2" FLAT WASHER	20	2	ANTI-REFLECTIVE TAPE (FOR CHROME ASSEMBLIES ONLY.)
12	8	1/2" LOCK WASHER			NOTE: NOT ALL FASTENERS WILL BE USED.
13	8	1/2-13 HEX NUT			

TOOLS REQUIRED

3/4" SOCKET	3/4" WRENCH	9/16" SOCKET	9/16" WRENCH	7/16" WRENCH
5/32" HEX WRENCH	18MM SOCKET	18MM WRENCH	19MM SOCKET	13MM SOCKET
RATCHET	SOCKET EXTENSION	TORQUE WRENCH		

- STEP 1. Remove the contents from box and check for damage. Verify all parts are present. Read instructions completely before beginning.
- STEP 2. Attach light guard assemblies as shown. **SEE FIGURE 1.**
- STEP 3. Open hood and attach support braces as shown **SEE FIGURES 2. NOTE:** Use rubber bumpers to keep mount braces off of bumper.
- STEP 4. From underneath vehicle, remove the 4 lower nuts holding the bumper frame to the main frame and the 2 body mount bolts, then attach top brackets as shown. **SEE FIGURE 2 .** Torque nuts and bolts to 65 FT.LBS.
- STEP 5. Attach bottom brackets using 1/2" fasteners as shown. **SEE FIGURE 2 .** Leave loose.
- STEP 6. Lift Sportsman up towards vehicle and attach as shown to both lower brackets and support braces. Center and level Sportsman. Torque 3/8" and 10mm support brace fasteners to 35 FT.LBS and 1/2" fasteners to 65 FT.LBS.
- STEP 7. **Slowly** lower hood and check for clearance between sportsman and hood and mount braces and hood. Reposition sportsman if necessary.
- STEP 8. For chrome assemblies. If light glare is being experienced off the wings of the Sportsman, anti-reflective tape has been supplied to reduce glare. With headlights on, note where the reflection is concentrated on the wing. Clean the wing well with a non-abrasive cleaner (rubbing alcohol works the best.) Trim the anti-reflective tape to the appropriate size where the glare was located and apply tape. **SEE FIGURE 1.**

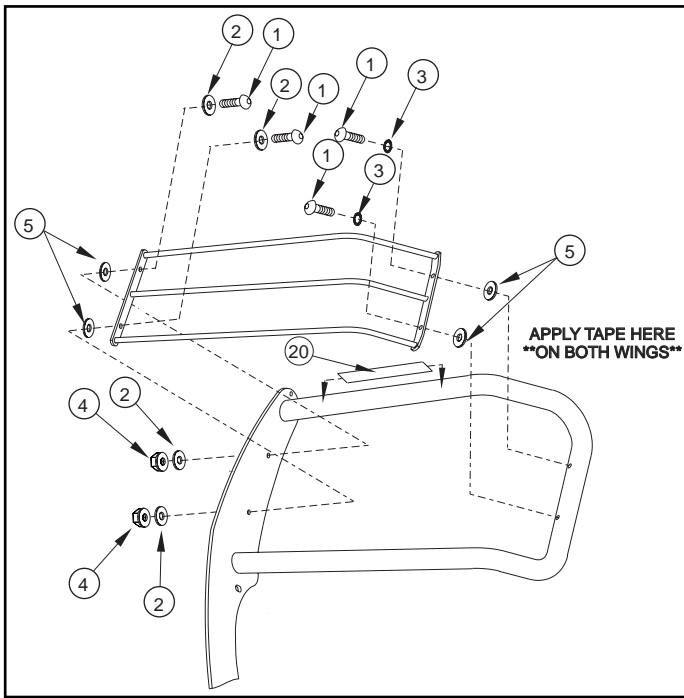

ITEM	QTY.	DESCRIPTION
1	8	1/4-20 X 1.00" BUTTON HEAD BOLT
2	8	1/4" FLAT WASHER
3	4	1/4" INTERNAL TOOTH LOCK WASHER
4	4	1/4-20 NYLON NUT
5	8	RUBBER WASHER

NOTE: ALL FASTENERS MAY NOT BE USED.

FIGURE 1
LIGHT GUARD INSTALLATION

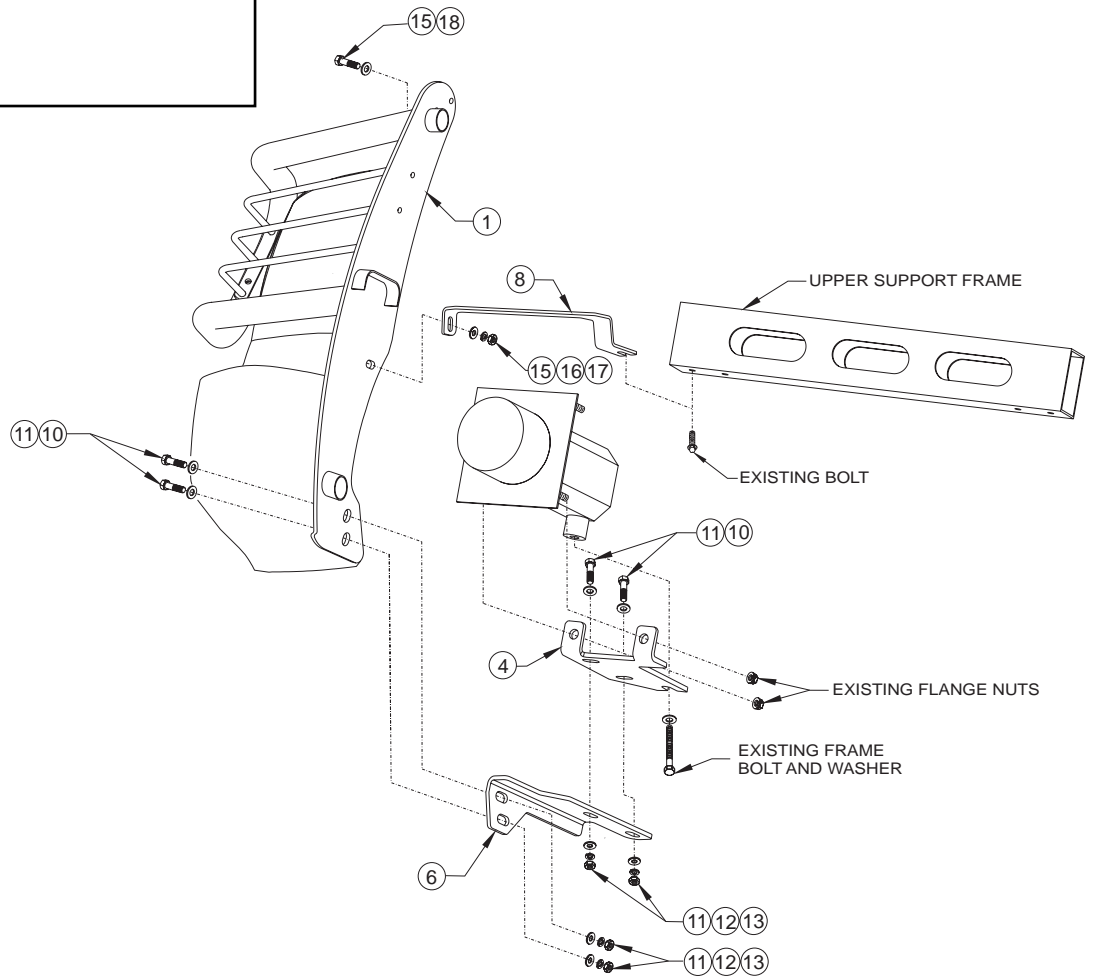

FIGURE 2
INSTALLATION VIEW OF PASSENGER SIDE,
DRIVER SIDE IS OPPOSITE

Finish protection - Westin products have a high quality finish that must be cared for like any other exposed finish on the vehicle. Protect the finish with a non-abrasive automotive wax (pure carnauba, for example) on a regular basis. The use of cleaner wax or any compound which contains an abrasive is detrimental, as the compounds scratch the finish and open it to corrosion.