

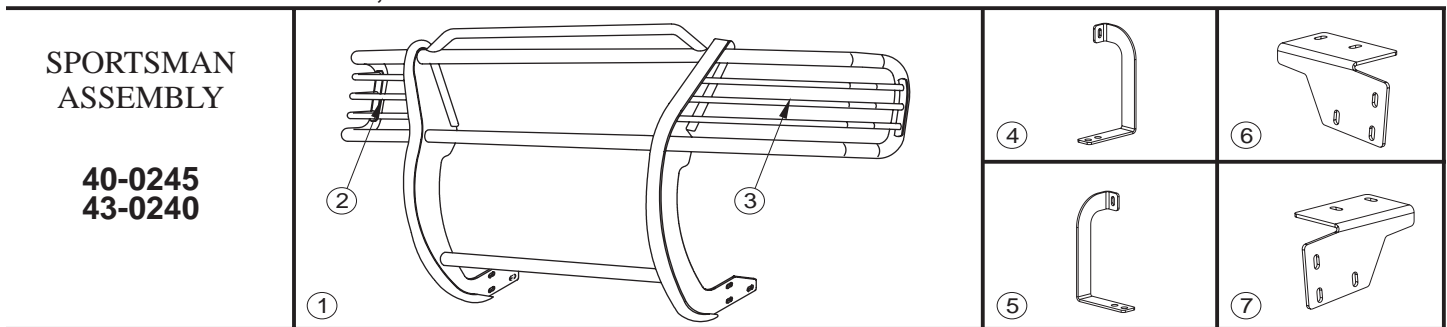

INSTALLATION INSTRUCTIONS

APPLICATION: 1997-04 FORD F-150/250 LIGHT DUTY(HERITAGE)
1997-02 FORD EXPEDITION
4 WHEEL DRIVE

AUTOMOTIVE PRODUCTS, INC.



PARTS KIT CONTENTS

ITEM	QTY	DESCRIPTION	ITEM	QTY	DESCRIPTION
1	1	SPORTSMAN ASSEMBLY	12	2	3/8-16 X 1.00" HEX HEAD BOLT
2,3	2	LIGHT GUARD ASSEMBLY, PASSENGER(2) AND DRIVER(3)	13	4	3/8" FLAT WASHER
4,5	2	TOP BRACKET, PASSENGER(4) AND DRIVER(5)	14	2	3/8" LOCK WASHER
6,7	2	BOTTOM BRACKET, PASSENGER(6) AND DRIVER(7)	15	2	3/8-16 HEX NUT
8	6	1/2-13 X 1.25" HEX HEAD BOLT	16	2	M12 X 1.75 HEX JAM REVERSIBLE NUT
9	12	1/2" FLAT WASHER	17	2	ANTI-REFLECTIVE TAPE (FOR CHROME ASSEMBLIES ONLY.)
10	6	1/2" LOCK WASHER			
11	6	1/2-13 HEX NUT			

TOOLS REQUIRED

3/4" SOCKET 3/4" WRENCH 9/16" SOCKET 9/16" WRENCH 7/16" WRENCH
5/32" HEX WRENCH 19MM SOCKET 15MM SOCKET RATCHET TORQUE WRENCH

- STEP 1. Remove the contents from box and check for damage. Verify all parts are present. Read instructions completely before beginning.
- STEP 2. Attach light guard assemblies as shown. **SEE FIGURE 1.**
- STEP 3. Remove tow hook by removing bolt 2 and loosening bolt 1. Slide tow hook toward rear and remove.
- STEP 4. Remove bolt 1, making sure the nut plate inside frame stays aligned with the frame hole for bolt 1.
- STEP 5. Hang bottom bracket in position by partially threading bolt 1 (without the tow hook) into nut plate.
- STEP 6. Align the nut plate by rotating bolt 1 back and forth so that bolt 2 can be inserted.
- STEP 7. Position the tow hook in place by hanging it by the slotted end first, then insert bolt 2.
- STEP 8. Tighten mount bolts so that bottom bracket is loose.
- STEP 9. Follow step 3 through 8 to install the opposite side bottom bracket.
- STEP 10. From inside of frame behind bumper, position top bracket so that front of bracket protrudes between top of bumper and bottom of grille. Push down on bumper cover to slide bracket through. Locate bumper bolt ends (front side of frame), then position hole of bracket on the end of the top bolt, over existing nut. Hand tighten supplied 12mm jam nut over bracket. Repeat for other side. **SEE FIGURE 2.**
NOTE: 1997-98 models use lower hole on bracket.
1999-01 models use upper hole on bracket.
- STEP 11. Place cardboard under front of vehicle. Lay Sportsman on cardboard with front side down.
- STEP 12. Slide unit back so that the rearmost slots align with the rearmost slots on the brackets. Fasten together the rear slots on both sides as shown. Hand tighten
- STEP 13. Rotate Sportsman up toward vehicle until remaining slots are aligned. Fasten bottom with remaining 1/2" fasteners. Attach to top brackets using 3/8" fasteners as shown. **SEE FIGURE 2.**
- STEP 14. Center and level Sportsman. Torque tow hook bolts to 75 FT. LBS; 12mm jam nuts to 60 FT.LBS; 12"

fasteners to 65 FT.LBS. and 3/8" fasteners to 30 FT.LBS.

STEP 8. For chrome assemblies. If light glare is being experienced off the wings of the grille guard, anti reflective tape has been supplied to reduce glare. With headlights on, note where the reflection is concentrated on the wing. Clean the wing well with a non-abrasive cleaner (rubbing alcohol works the best.) Trim the anti-reflective tape to the appropriate size where the glare was located and apply tape. **SEE FIGURE 1.**

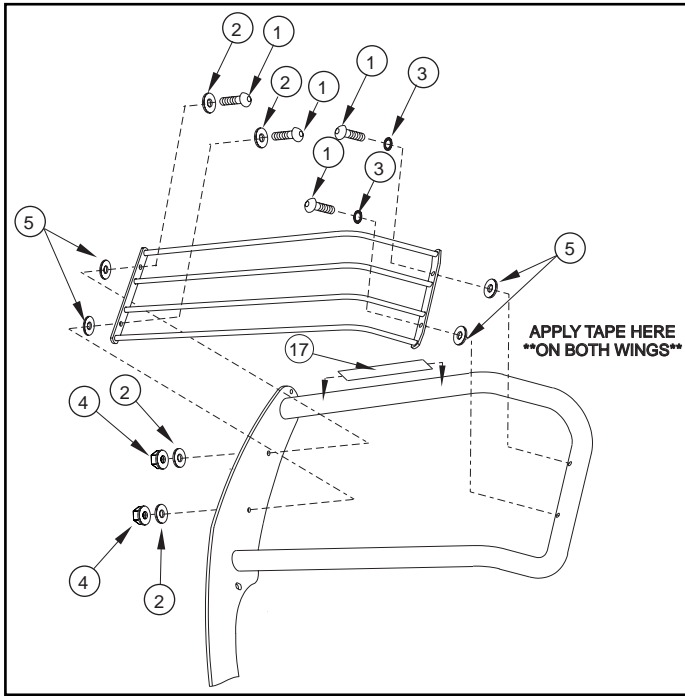

ITEM	QTY.	DESCRIPTION
1	8	1/4-20 X 1.00" BUTTON HEAD BOLT
2	8	1/4" FLAT WASHER
3	4	1/4" INTERNAL TOOTH LOCK WASHER
4	4	1/4-20 NYLON NUT
5	8	RUBBER WASHER

NOTE: ALL FASTENERS MAY NOT BE USED.

FIGURE 1
LIGHT GUARD INSTALLATION

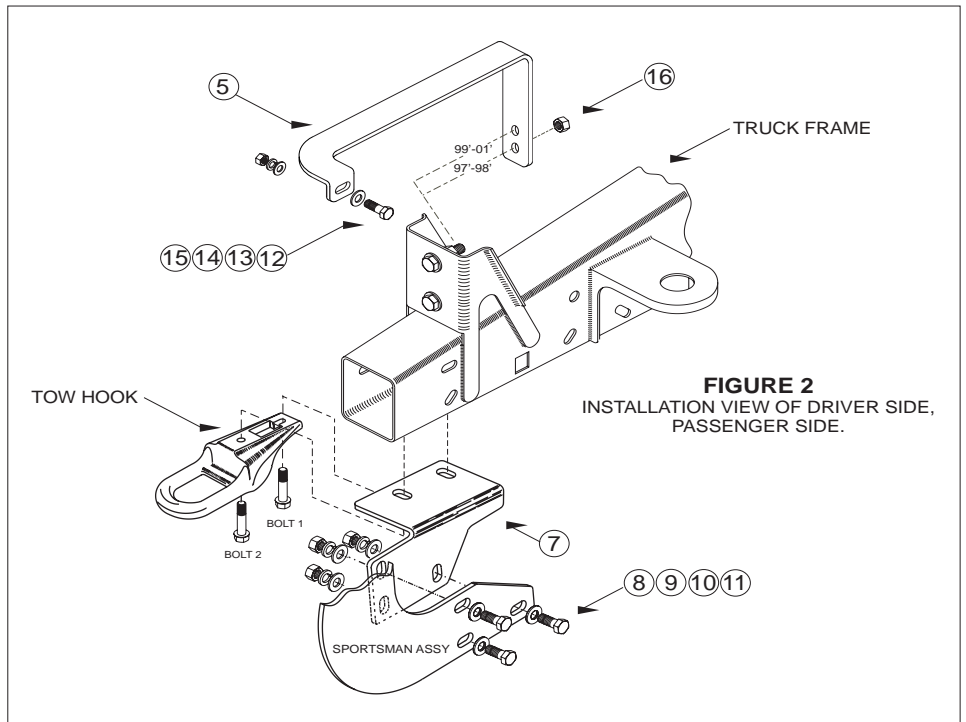

FIGURE 2
INSTALLATION VIEW OF DRIVER SIDE,
PASSENGER SIDE.

Finish protection - Westin products have a high quality finish that must be cared for like any other exposed finish on the vehicle. Protect the finish with a non-abrasive automotive wax (pure carnauba, for example) on a regular basis. The use of cleaner wax or any compound which contains an abrasive is detrimental, as the compounds scratch the finish and open it to corrosion.