



AUTOMOTIVE PRODUCTS,

INSTALLATION INSTRUCTIONS

4" OVAL TUBE MOUNT KIT

APPLICATION:

2006-2014 Toyota FJ Cruiser

PART NUMBER:

22-1615

ITEM	QUANTITY	DESCRIPTION	TOOLS NEEDED
1,2	2	STEP BAR, PASSENGER (1) AND DRIVER (2) (SOLD SEPERATELY)	7/16" SOCKET
3	4	MOUNT ASSEMBLY	13MM SOCKET
4	8	M8 HEX HEAD BOLT	13MM WRENCH
5	8	3/8" LOCK WASHER	RATCHET
6	8	3/8" FLAT WASHER	TORQUE WRENCH
7	4	MOUNT ADAPTER PLATE (INCLUDED WITH STEP BARS)	
8	16	M6 LOCK NUT (INCLUDED WITH STEP BARS)	
9	16	M6 FLAT WASHER (INCLUDED WITH STEP BARS)	

ANTI-SEIZE LUBRICANT MUST BE USED ON ALL STAINLESS STEEL FASTENERS TO PREVENT THREAD DAMAGE AND GALLING

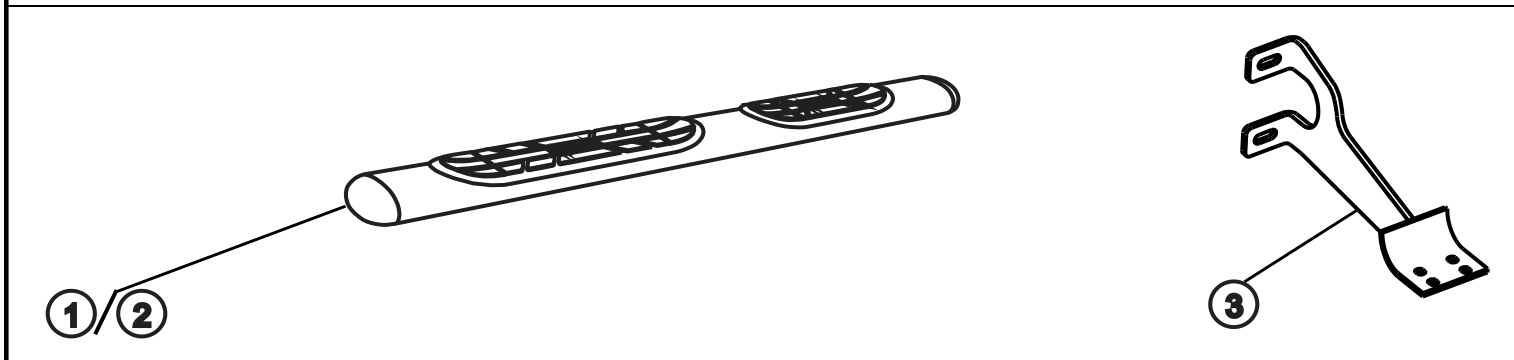

PROCEDURE

- Remove contents from box, verify if all parts listed are present and free from damage. Carefully read and understand all instructions before attempting installation.
Failure to identify damage before installation could lead to a rejection of any claim.
NOTE: Factory rocker bars or step boards must be removed before installing step bars.
- Locate the driver side mount locations on vehicle. There are four sets of threaded holes along the side of the frame. From the front of the vehicle, the first and last set of holes are used.
- Attach brackets to vehicle frame using two M8 hex head bolts, 3/8" flat washers, and 3/8" lock washers per bracket. Hand tighten. **SEE FIGURE 1. NOTE:** Do not pinch or crush brake lines with brackets.
- Slide mount adapter plates on step bar as shown. Place step bar on saddle with long pad forward and end cap screw facing inward. Assemble with M6 hardware. **See FIGURES 2, 3, & 4.** Reference installation sheet, 75-0820, Oval Tube Mount Adapter Kit.
- Make sure step bar and brackets are properly aligned with vehicle and tighten fasteners. Recommended torque values are 26 FT.LBS. for 3/8" fasteners and 20 FT.LBS. for M8 fasteners.



Westin Automotive Products, Inc.
320 W. Covina Blvd
San Dimas, Ca. 91773

Thank you for choosing Westin products
for additional installation assistance please call
Customer Service (800) 793-7846
www.westinautomotive.com

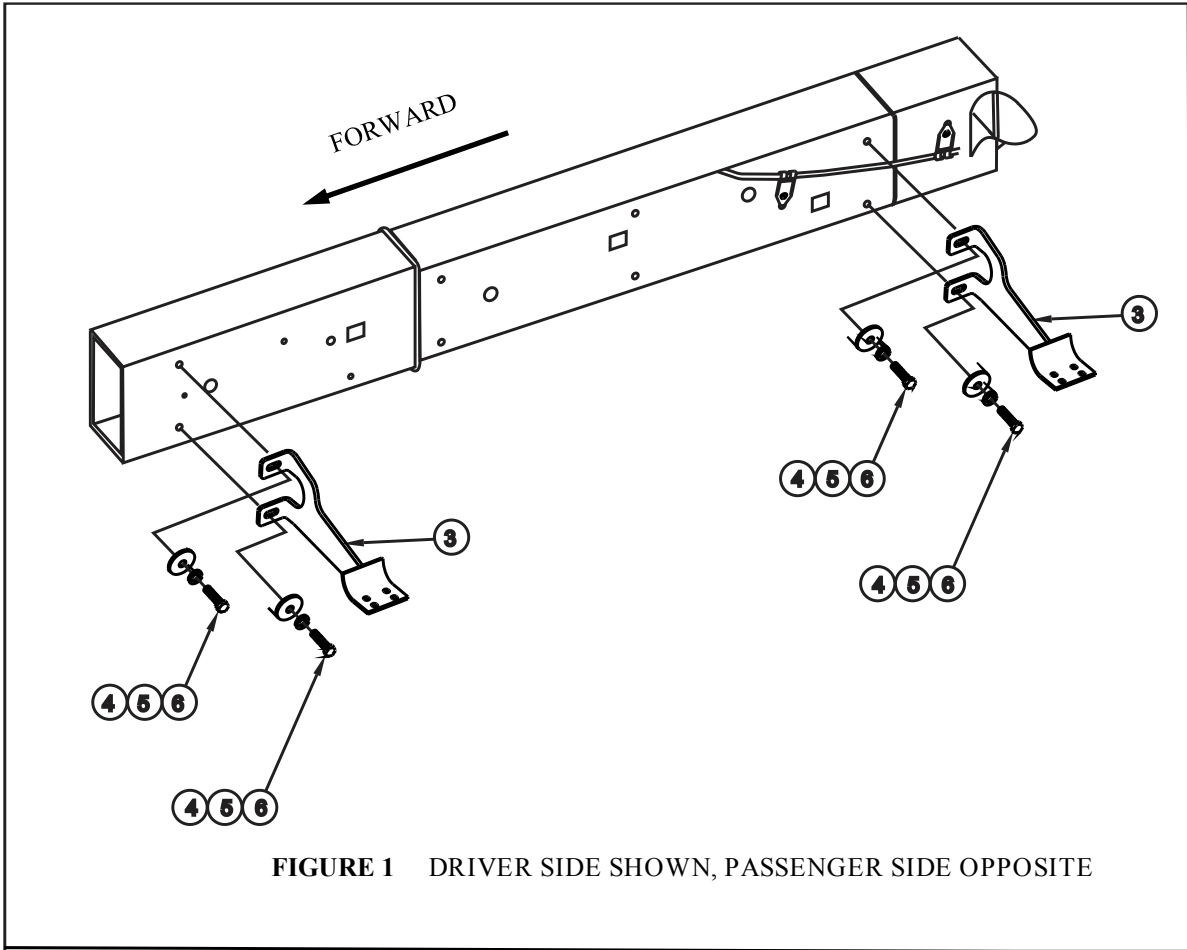

Westin Automotive Products, Inc.
 320 W. Covina Blvd
 San Dimas, Ca. 91773

Thank you for choosing Westin products
 for additional installation assistance please call
 Customer Service (800) 793-7846

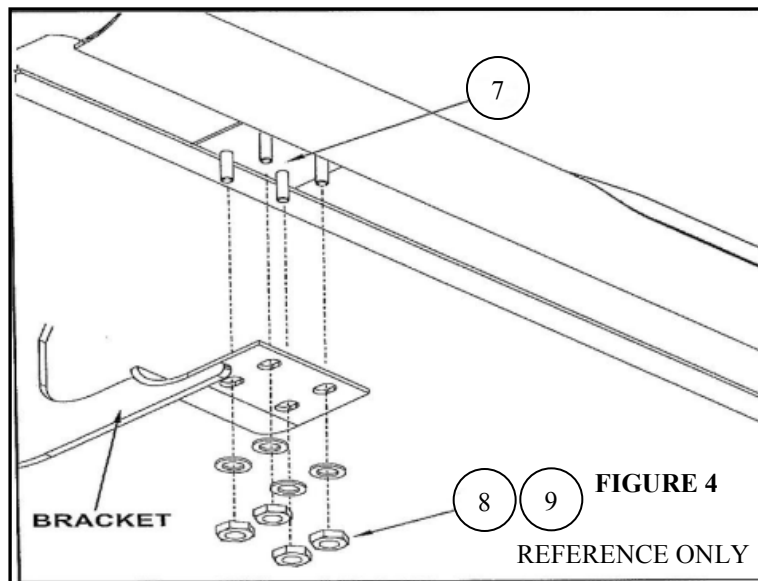
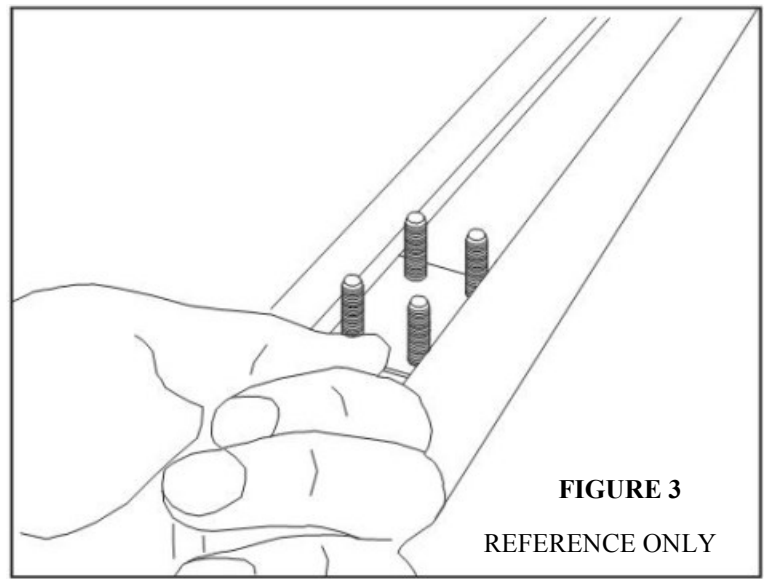
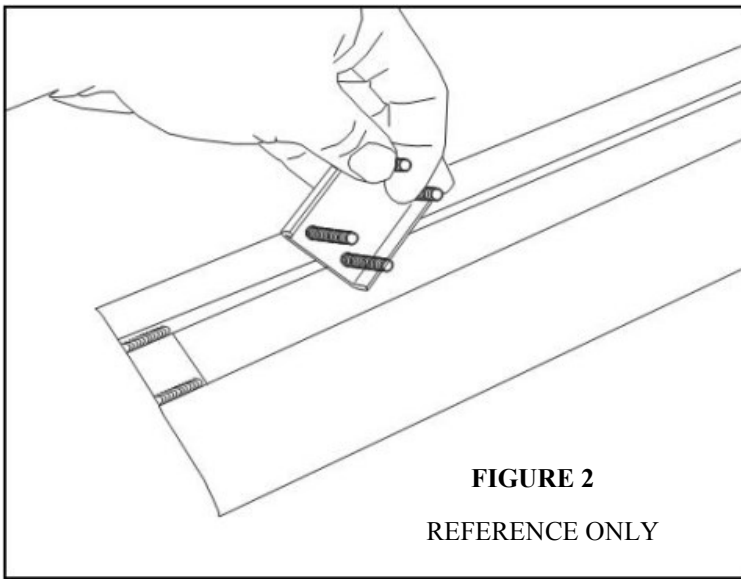

CARE INSTRUCTIONS

- REGULAR WAXING IS RECOMMENDED. DO NOT USE ANY TYPE OF POLISH OR WAX THAT MAY CONTAIN ABRASIVES.
- STAINLESS STEEL PRODUCTS CAN BE CLEANED WITH MILD SOAP AND WATER. STAINLESS STEEL POLISH SHOULD BE USED TO POLISH SMALL SCRATCHES.
- GLOSS BLACK FINISHES SHOULD BE CLEANED WITH MILD SOAP AND WATER.



Westin Automotive Products, Inc.
320 W. Covina Blvd
San Dimas, Ca. 91773

Thank you for choosing Westin products
for additional installation assistance please call
Customer Service (800) 793-7846
www.westinautomotive.com